

Sign

ernestomeda

Design innovativo, avanguardia tecnologica, ricerca costante e grande passione per la qualità: questi i tratti distintivi della filosofia Ernestomeda.

La vocazione alla sperimentazione e all'innovazione si traduce nella cura dei dettagli e nelle soluzioni altamente personalizzabili.

I progetti di Ernestomeda sono il risultato della sintesi tra il know-how aziendale e l'originale visione del progetto di Giuseppe Bavuso.

Innovative design, leading-edge technology, constant research and a great passion for quality: these are the Ernestomeda core values.

A vocation for experimentation and innovation expressed in carefully crafted details and solutions with vast scope for customisation.

Ernestomeda projects embody the company's unique know-how with the original design vision of Giuseppe Bavuso.



Sign

Un'idea di casa intesa come spazio aperto, in cui gli ambienti possano interagire e integrarsi tra di loro. La cucina non più interpretata come un semplice spazio chiuso di lavoro, ma una vera e propria estensione del living, fulcro della casa dedicato alla convivialità. Sign, dal punto di vista progettuale, è pensata per esprimere contenuti d'alto valore formale ed estetico, senza tralasciare l'aspetto funzionale, con livelli prestazionali delle attrezzature molto vicini a quelli professionali. Sign è una cucina informale, caratterizzata da una grande attenzione per i materiali, in un mix di cromatismi che creano ambienti molto eleganti e dal forte impatto emotivo. Fulcro del progetto è l'elegante boiserie a giorno priva di pensili chiusi, che lasciano spazio a mensole e vetrine, vere e proprie aree espositive che creano continuità e armonia con la zona living. Integrato perfettamente nelle armadiature, Inside Passage è il sistema di ante rototraslanti ad impacchettamento laterale brevettato, appositamente progettato per Ernestomeda, vero e proprio elemento di collegamento tra la cucina e l'area adiacente. Consente l'accesso all'area Back System, una struttura a spalla portante che assolve a tutti i servizi della casa, che può essere dotata con specifiche attrezzature, in funzione delle diverse esigenze per diventare una wine cellar, una lavanderia o una dispensa dedicata allo stoccaggio di cibi e utensili. Un'area della casa perfettamente organizzata e attrezzata.

design
Giuseppe Bavuso

A concept of the home as an open space, in which rooms can interact and integrate with each other. The kitchen is no longer interpreted as just an enclosed working space; instead, it is a genuine extension of the living area, the fulcrum of the home, dedicated to spending time together. In design terms, Sign, the new kitchen created for Ernestomeda, is conceived with contents of high formal and aesthetic value but without neglecting the functional aspect, with equipment performance levels very close to professional standards.

Sign is a kitchen with an informal character, with a strong focus on materials, in a mix of colours that generates very elegant interiors with strong emotional impact. The centre of the kitchen's design is the elegant open boiserie structure, with enclosed wall units replaced by shelves and glass-fronted cabinets, real display areas that create continuity and harmony with the living area. Perfectly integrated in the cupboard systems, Inside Passage is the patented system of doors which rotate and stow in a pack at the side, custom-designed for Ernestomeda to provide the vital linkage between the kitchen and the adjoining area. Inside Passage gives access to the Back System area, a free-standing structure that covers all the home's utility functions and can be specifically equipped to suit different requirements, becoming a wine cellar, a laundry, or a pantry for storing food and kitchen utensils. A perfectly organised, equipped area of the home.

design
Giuseppe Bavuso

Oggi l'ambiente cucina interpreta ruoli diversi, ampliando le proprie funzioni e assumendo le qualità estetiche tipiche dell'area living. Così la ricerca e il design si estendono dall'ambito tecnico ai dettagli formali, alle finiture.

Nowadays the kitchen plays a variety of roles, extending its functions and acquiring stylistic qualities previously associated with the living area. So research and design now reach beyond the technical to embrace details of form and finishing.



Al centro dello spazio l'isola operativa con tavolo Line Table integrato concentra le funzioni dedicate alla preparazione e al consumo conviviale. Il risultato è una soluzione di forte personalità, che invita a vivere la cucina in modo originale e stimolante.

In the centre of the space, the working island with integral Line Table that combines the functions of food preparation and social eating. The result is a strongly characterful invitation to experience the kitchen in an exciting new way.





Piano di lavoro in acciaio satinato con zona lavaggio integrata Able. Sistema Bridge (patent) sopra top in laccato metallo lucem.

Worktop in satined steel with Able integral washing zone. Worktop Bridge system (patent) in lucem metal lacquered finish.





Basi in hi-melamine noce canyon
canneté con maniglia Zed laccato
metallo lucem.

Base units in canneté canyon walnut
hi-melamine with lucem metal
lacquered Zed handle.





Colonne laccato metallo satinato
bronzo con maniglia Lever nella stessa
tonalità.

Tall units in bronze satined metal
lacquered finish with matching Lever
handle.



Colonne a giorno Daylight (patent) in hi-melamine noce canyon con cornice anteriore retro-illuminata in laccato metallo satinato bronzo.

Daylight open tall units (patent) in canyon walnut hi-melamine with backlit front surround in bronze satined metal lacquered finish.



Colonne in hi-melamine noce canyon con profilo Zed verticale laccato metallo satinato bronzo.
All'interno accessori Fit composti da ripiani fissi con telaio in laccato metallo lucem e vetro grigio trasparente e ripiani estraibili con struttura alluminio laccato metallo lucem e fondo hi-melamine noce canyon.

Tall units in canyon walnut hi-melamine with vertical Zed groove strip in bronze satined metal lacquered finish. Inside, Fit accessories comprising fixed shelves with lucem metal lacquered frame and clear grey glass and pull-out shelves with lucem metal lacquered aluminium structure and canyon walnut hi-melamine bottom.





Sistema Surf di attrezzature interne modulari per cassetti con sponde Legrabox. Struttura in alluminio laccato metallo lucem con divisori in rovere nordic.

Surf System modular internal fittings for drawers with Legrabox sides. Lucem metal lacquered aluminium structure with nordic oak partitions.





Attrezzatura Fit composta da cassetti con sponde in alluminio laccato metallo lucem e fondo in hi-melamine noce canyon.

Fit equipment comprising drawers with lucem metal lacquered aluminium sides and canyon walnut hi-melamine bottom.



Cappa K-System acciaio satinato con ripiani in massello bambù tinto noce canyon.

K-System hood in satined steel with canyon walnut stained solid bamboo shelves.



Il sistema Inside Passage permette di collegare l'ambiente cucina con aree dedicate a funzioni specifiche, come una "cantina" privata perfettamente attrezzata, realizzata con il programma Back System. The Inside Passage system enables the kitchen to be connected to special-purpose areas, such as a fully equipped private "wine cellar", created using the Back System programme.







Back System: spalle, schienali,
ripiani fissi, cassetti e cassettiere in
hi-melamine olmo namib e accessori
Fit laccato metallo lucem.

Back System: uprights, back panels,
fixed shelves, drawers and drawer
units in namib elm hi-melamine with
lucem metal lacquered Fit accessories.





Parete Back System organizzata con le attrezzature specifiche per l'area cantina.

Back System wall organised with specific equipment for the wine cellar area.



L'immagine di Sign entra in sintonia con l'area living, mentre le funzioni si estendono ad aree distinte, attrezzate con soluzioni specifiche. Ogni dettaglio nasce da scelte precise, risultato di una ricerca estetica e funzionale costante.

Sign's image harmonises with the living area, while its functions extend into separate zones equipped with specific solutions. Every detail is the outcome of precise choices, constantly fresh in style and innovative in function.



Dalla parete, l'area operativa si estende al centro dell'ambiente con una penisola attrezzata. Sullo sfondo, un'elegante boiserie a giorno che diventa una vera e propria area espositiva in continuità e armonia con l'area living.

An equipped peninsula extends the working area from the wall to the centre of the room. In the background, an elegant open boiserie panel becomes a true display area, continuing and harmonising with the living area.





Basi in Fenix beige arizona, anta con maniglia Zed laccato flat matt beige arizona.

Base units in arizona beige Fenix, doors with arizona beige flat matt lacquered Zed handle.









Pensile View con struttura in hi-melamine olmo namib. Telaio, fianchi e ante in laccato metallo lucem e vetro chiaro riflettente. Piano di lavoro in Fenix beige arizona con zona lavaggio integrata Able. Tagliere in massello bambù tinto olmo namib.

View wall unit with namib elm hi-melamine structure. Frame, side panels and doors in lucem metal lacquered finish and clear reflective glass. Worktop in arizona beige Fenix with Able integral washing zone. Chopping boards in namib elm stained solid bamboo.





Boiserie attrezzata con pannellatura Set in hi-melamine olmo namib canneté e scaffaletti a giorno Stay (patent) in hi-melamine olmo namib con frontalino antiribaltamento laccato metallo lucem.

Equipped boiserie panel with Set panelling in canneté namib elm hi-melamine and Stay open shelves (patent) in namib elm hi-melamine with lucem metal lacquered anti-tipping front.



Cantina, dispensa, piccola lavanderia:
la combinazione tra i sistemi Inside
Passage e Back System consente
la definizione di spazi di servizio
complementari all'ambiente cucina.
Wine cellar, larder, small laundry: the
combination of Inside Passage and
Back System enables the creation
of utility spaces that complement the
kitchen itself.



Back System: spalle in hi-melamine beige phoenix con schienali, ripiani fissi e cassette in hi-melamine olmo namib e accessori Fit in laccato metallo lucem.

Back System: uprights in phoenix beige hi-melamine with back panels, fixed shelves and drawers in namib elm hi-melamine with lucem metal lacquered Fit accessories.



Back System interpretato per una soluzione cantina con attrezzatura portacalici e cassetto con accessori Surf.

Back System used to create a wine cellar with stem glass racks and drawer with Surf accessories.



Perfettamente coordinato nelle finiture alla cucina Sign, il sistema Daylight permette la definizione di contenitori attrezzati. Una soluzione pensata per completare le possibilità progettuali dell'ambiente cucina. With finishes perfectly matched with the Sign kitchen, the Daylight system is ideal for constructing equipped storage units. A solution conceived to complete the kitchen's design potentials.





Sistema a giorno Daylight (patent) con struttura in hi-melamine olmo namib e cornice anteriore retro-illuminata in laccato metallo lucem e cassetto con fondo in ecopelle bordeaux.

Daylight open system (patent) with namib elm hi-melamine structure and backlit front surround in lucem metal lacquered finish; drawer with bordeaux eco-leather bottom.



Vetrina View con struttura in hi-melamine
olmo namib. Telaio, fianchi e ante laccato
metallo lucem e vetro chiaro riflettente.

View glass-fronted unit with namib elm
hi-melamine structure. Frame, side panels
and doors in lucem metal lacquered finish
and clear reflective glass.



Sign propone una nuova idea di cucina, una dimensione aperta e coerente al resto della casa. Così l'area operativa assume una nuova immagine e intorno ad essa trovano spazio soluzioni di contenimento coordinate, diversamente attrezzate.

Sign offers a new idea of the kitchen, an open area styled to blend into the rest of the home. So the working area changes its image and is surrounded by coordinated storage solutions equipped in different ways.



Compatta, monomaterica, perfettamente accessoriata: è l'isola operativa in finitura stone+ nevada canneté, completata dai vani a giorno Daylight (patent) hi-melamine rovere teide. Una proposta originale, caratterizzata da una serie di soluzioni tecniche e formali inedite.

Compact, single-material and perfectly equipped: the working area in canneté nevada stone+ is completed by the teide oak hi-melamine Daylight open units (patent). An original idea featuring a series of unusual technical and formal solutions.





Basi con anta telaio Zed Frame
in laccato metallo lucem e
stone+ nevada canneté (esclusivo
ernestomeda).

Base units with Zed Frame door in
lucem metal lacquered finish and
canneté nevada stone+ (exclusive to
ernestomeda).





Piano di lavoro MDI induction nevada by Inalco (esclusivo ernestomeda) con zona lavaggio/cottura integrate Able. Sistema Bridge sopra piano (patent), laccato metallo lucem con accessori in rovere termotrattato. Soluzione snack Move on Plus (patent) con piano scorrevole in hi-melamine rovere teide e vano attrezzato portautensili in hi-melamine olmo namib.

MDI induction nevada by Inalco worktop (exclusive to ernestomeda) with Able integral washing/cooking zone. Worktop Bridge system (patent) in lucem metal lacquered finish with heat-treated oak accessories. Move-on Plus snack solution (patent) with sliding top in teide oak hi-melamine and namib elm hi-melamine equipped utensil compartment.





Dettaglio della zona cottura integrata
Able in MDI induction nevada
by Inalco (esclusivo ernestomeda).
Nella pagina seguente: penisola
scorrevole Move-on Plus (patent) con
piano in hi-melamine rovere teide e
interni in hi-melamine olmo namib.

Detail of Able integrated cooking
zone in MDI induction nevada
by Inalco (exclusive to ernestomeda).
Next page: Move-on Plus sliding
peninsula (patent) with top in teide
oak hi-melamine and namib elm
hi-melamine interiors.







Colonne laccato zero gloss island con maniglia Trace in laccato zero gloss island.

Island zero gloss lacquered tall units with island zero gloss lacquered Trace handle.



Sistema Daylight (patent) per basi con struttura in hi-melamine rovere teide e cornice anteriore retro-illuminata in laccato metallo lucem.

Daylight base unit system (patent) with teide oak hi-melamine structure and backlit front surround in lucem metal lacquered finish.



Colonne a giorno Daylight (patent) con struttura in hi-melamine rovere teide e cornice anteriore retroilluminata in laccato metallo lucem.

Daylight open tall units (patent) with teide oak hi-melamine structure and backlit front surround in lucem metal lacquered finish.



Il progetto Sign è arricchito da soluzioni che ne completano le potenzialità, sia in termini funzionali che estetiche. Come i contenitori sospesi View, caratterizzati dalla completa trasparenza.

The Sign project features solutions that complete its potentials in both functional and stylistic terms. Such as the View completely transparent wall-mounted storage units.



Vetrina sospesa View con struttura in hi-melamine caucasio, ante e fianchi laccato zero gloss nero e vetro grigio trasparente. Schienale in laccato zero gloss salvia. Cassetto con fondo in ecopelle brownish.

View wall-mounted glass-fronted cabinet in caucasus high-melamine, doors and sides in black zero gloss lacquered finish and clear grey glass. Back panel sage zero gloss lacquered. Drawer with brownish eco-leather bottom.



Il carattere di Sign è sottolineato dall'originalità delle scelte tecniche, dall'esclusività delle finiture, da un concept generale che supera i confini della cucina tradizionale per offrire soluzioni funzionali ad un nuovo modo di abitare.

Sign's personality is emphasised by its original technical features, its exclusive finishes and a general concept that breaks out of the confines of the traditional kitchen to offer fresh functional solutions and a new lifestyle.



Al centro della composizione un'area operativa composta dal top Dual con piano cottura e vasca integrati. All'estremità il pratico tavolo a penisola Line Table e sullo sfondo la boiserie in hi-melamine noce canyon canneté, elemento comune di forte caratterizzazione estetica.

In the centre of the composition, a working area consisting of the Dual worktop with integral hob and sink. At one end, the Line Table convenient peninsula table, and in the background the boiserie panel in canneté canyon walnut hi-melamine, a linking element that provides a strong stylistic character.





Tavolo Line Table con piano in hi-melamine noce canyon e basamento in laccato metallo lucem.

Line Table with canyon walnut hi-melamine top and lucem metal lacquered finish base.







Basi con anta in Fenix grigio etna e maniglia Zed in laccato flat matt grigio etna. Piano di lavoro in stone+ cervino tarmac.

Base units with door in etna grey Fenix and Zed handle in etna grey flat matt lacquered finish. Worktop in cervino tarmac stone+.



Pensili In-Line con struttura in hi-melamine noce canyon. Telaio fianchi in laccato metallo lucem. Vetro fianchi grigio trasparente e anta in Fenix grigio londra.

In-Line wall units with canyon walnut hi-melamine carcass. Side panel frame in lucem metal lacquered finish. Clear grey glass for side panels and door in london grey Fenix.



Sistema Double Indoor con struttura in hi-melamine noce canyon, con ante rientranti ad impacchettamento in Fenix grigio etna. Basi sospese in Fenix grigio etna. Piano di lavoro e alzatina in acciaio satinato, tagliere in bambù tinto noce canyon e boiserie attrezzata con pannellatura Set in hi-melamine noce canyon canneté e scaffaletti a giorno Stay (patent) in hi-melamine noce canyon.

Double Indoor system with canyon walnut hi-melamine module, with retracting pocket doors in etna grey Fenix. Wall-mounted base units in etna grey Fenix. Worktop and upstand in satined steel, chopping board in canyon walnut stained bamboo, and equipped boiserie panel with Set panelling in canneté canyon walnut hi-melamine and Stay shelves (patent) in canyon walnut hi-melamine.





Colonna angolo attrezzata con cestelli estraibili Le Mans.

Comer tall unit fitted with Le Mans pull-out baskets.



Il programma Back System consente la definizione di spazi dedicati, complementari all'ambiente cucina. Come una piccola lavanderia, perfettamente attrezzata per ogni specifica funzione.

The Back System programme enables the creation of special-purpose spaces that complement the kitchen itself. Such as a small laundry, perfectly equipped for every specific function.



Back System: soluzione lavanderia con spalle, ripiani fissi, cassetti e cassettiere in hi-melamine beige Fenix. Schienali in hi-melamine noce canyon e accessori Fit in laccato metallo lucem.

Back System: laundry solution with uprights, fixed shelves, drawers and drawer units in beige Fenix hi-melamine. Back panels in canyon walnut hi-melamine and Fit accessories in lucem metal lacquered finish.



Parete Back System organizzata con le attrezzature specifiche per l'area lavanderia.

Back System wall organised with specific equipment for the laundry area.





Dettaglio modularità Back System con accessori Fit con sacca porta biancheria e tubo appendi abiti in laccato metallo lucem.

Detail of modularity of Back System with Fit accessories with laundry bag and clothes hanging rail in lacquered metal lacquered finish.



La varietà delle finiture previste per i diversi componenti di Sign consente un numero straordinario di possibili combinazioni. Un capitolo dedicato a questo tema consente di valutarne il risultato estetico e quindi favorire la scelta in fase di progetto.

The variety of finishes available for Sign's different components enables an amazing number of possible combinations. A section dedicated to this topic allows resulting appearances to be assessed in advance, facilitating design choices.

Possibilità estetiche Finishes and materials	
Anta con profilo Zed Door with Zed profile	142
Anta a Telaio Zed Frame Zed Frame Door	146
Top con vaso Able Worktop with Able recess	148
Piano snack Move-on Plus Move-on Plus snack top	149
Attrezzatura cassette Surf Surf drawer equipment	150
Sistema attrezzato sopratop Bridge Bridge worktop tidy system	151
Boiserie Set attrezzata con elementi a giorno Stay Set Boiserie Panel equipped with Stay open elements	152
Anta colonne Tall unit door	156
Maniglie colonne Tall Unit Handles	157
Sistema Daylight Daylight System	158
Cassetti Drawers	159
Pensile e Colonne Vetrine View View Glass-Fronted Wall and Tall Units	160
Back System	162
Attrezzature Fit Fit Equipment	164

Cromie
Colour shades



Laccato zero gloss
nella foto: anta, profilo e gola grigio nuage
Zero gloss lacquered
in photo: nuage grey door, profile and groove strip



Laccato flat matt
nella foto: anta grigio antrim, profilo e gola laccato metallo lucem
Flat matt lacquered
in photo: antrim grey door, lucem metal lacquered profile and groove strip

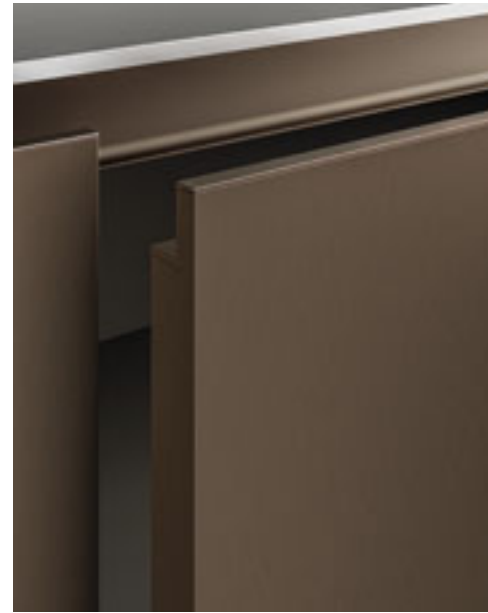

Laccato effetto metallo satinato
nella foto: anta, profilo e gola umber
Satined metal effect lacquered
in photo: umber door, profile and groove strip

Impiallacciato
Veneer



Rovere nordic
nella foto: profilo e gola laccato metallo lucem
Nordic oak
in photo: lucem metal lacquered profile and groove strip



Olmo caramello
nella foto: profilo e gola laccato effetto metallo satinato titanium
Caramel elm
in photo: titanium satined metal lacquered profile and groove strip

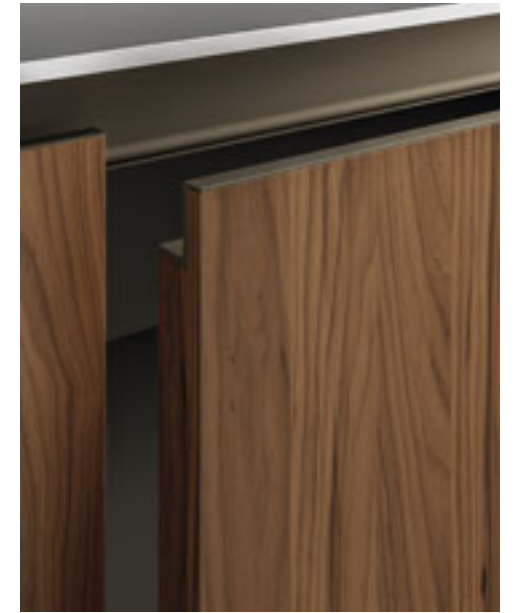

Noce canaletto
nella foto: profilo e gola laccato effetto metallo satinato bronzo
Canaletto walnut
in photo: bronze satined metal effect lacquered profile and groove strip



Fenix
nella foto: anta, profilo e gola grigio seta
in photo: silk grey door, profile and groove strip



Laminato
nella foto: anta grigio ghisa opaco, profilo e gola laccato metallo lucem
Laminate
in photo: matt cast-iron grey door, lucem metal lacquered profile and groove strip



Hi-melamine
nella foto: anta, profilo e gola grigio autunno
in photo: autumn grey door, profile and groove strip



Rovere cenere
nella foto: profilo e gola laccato effetto metallo satinato titanium
Ash grey oak
in photo: titanium satined metal lacquered profile and groove strip

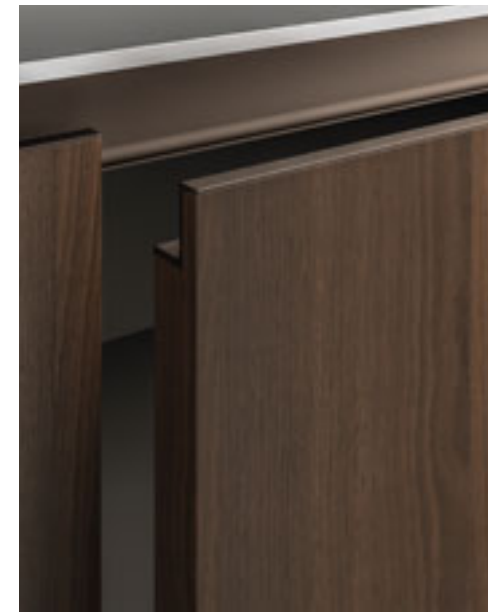

Rovere termotrattato
nella foto: profilo e gola laccato effetto metallo satinato umber
Heat-treated oak
in photo: umber satined metal effect lacquered profile and groove strip

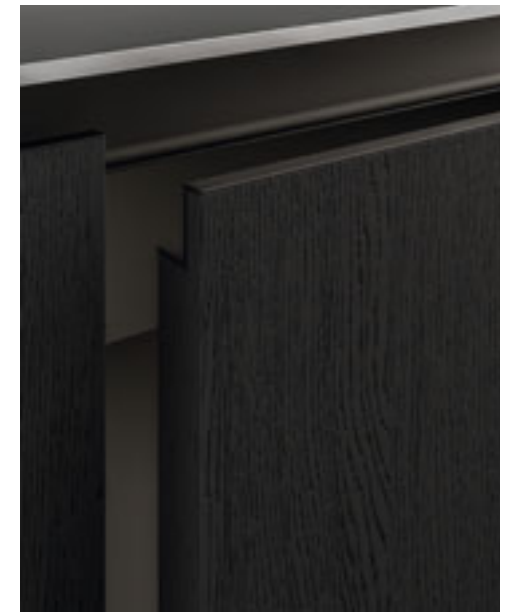

Rovere nero a poro aperto
nella foto: profilo e gola laccato effetto metallo satinato ferrum
Open pore black oak
in photo: ferrum satined metal effect lacquered profile and groove strip

Hi-melamine effetto legno
Wood effect hi-melamine



Olmo namib
nella foto: profilo e gola laccato metallo lucem
Namib elm
in photo: lucem metal lacquered profile and groove strip



Noce canyon
nella foto: profilo e gola laccato effetto metallo satinato bronzo
Canyon walnut
in photo: bronze satined metal effect lacquered profile and groove strip



Rovere teide
nella foto: profilo e gola laccato effetto metallo satinato umber
Teide oak
in photo: umber satined metal effect lacquered profile and groove strip

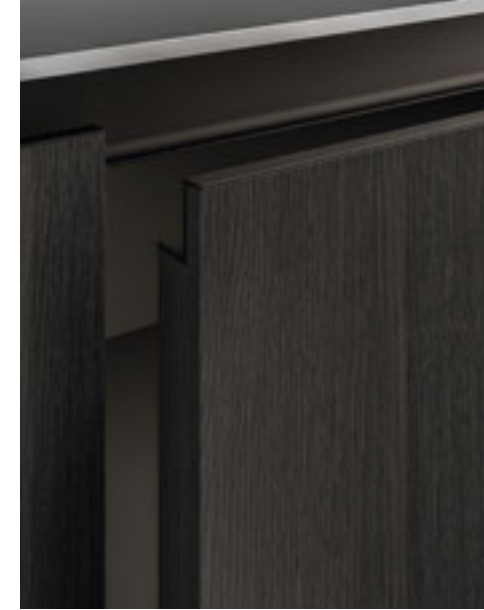

Caucaso
nella foto: profilo e gola laccato effetto metallo satinato ferrum
Caucasus
in photo: ferrum satined metal effect lacquered profile and groove strip



Olmo namib canneté
nella foto: profilo e gola laccato metallo lucem
Canneté namib elm
in photo: lucem metal lacquered profile and groove strip



Noce canyon canneté
nella foto: profilo e gola laccato effetto metallo satinato bronzo
Canneté canyon walnut
in photo: bronze satined metal effect lacquered profile and groove strip

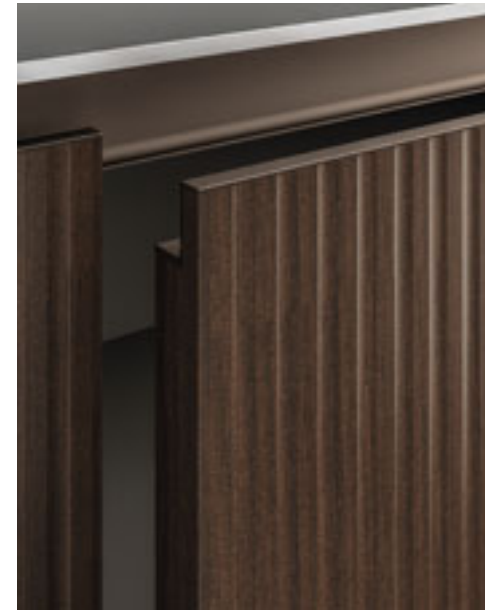

Rovere teide canneté
nella foto: profilo e gola laccato effetto metallo satinato umber
Canneté teide oak
in photo: umber satined metal effect lacquered profile and groove strip

Stone+



Nevada canneté
nella foto: telaio e gola laccato metallo lucem
Canneté nevada
in photo: lucem metal lacquered frame and groove
strip



Cervino tarmac
nella foto: telaio e gola laccato metallo lucem
in photo: lucem metal lacquered frame and groove
strip



Rock bahama beige
nella foto: telaio e gola laccato metallo lucem
in photo: lucem metal lacquered frame and groove
strip



Mercury brown
nella foto: telaio e gola laccato metallo lucem
in photo: lucem metal lacquered frame and groove
strip



Thunder grey
nella foto: telaio e gola laccato metallo lucem
in photo: lucem metal lacquered frame and groove
strip



Sirio
nella foto: telaio e gola laccato metallo lucem
in photo: lucem metal lacquered frame and groove
strip

Vetro
Glass



Opaco
nella foto: anta grigio efeso, gola e telaio laccato
flat matt grigio efeso
Matt
in photo: ephesus grey door, ephesus grey flat matt
lacquered groove strip and frame



Lucido
nella foto: anta grigio bromo, gola e telaio laccato
flat matt grigio bromo
Gloss
in photo: bromine grey door, bromine grey flat
matt lacquered groove strip and frame

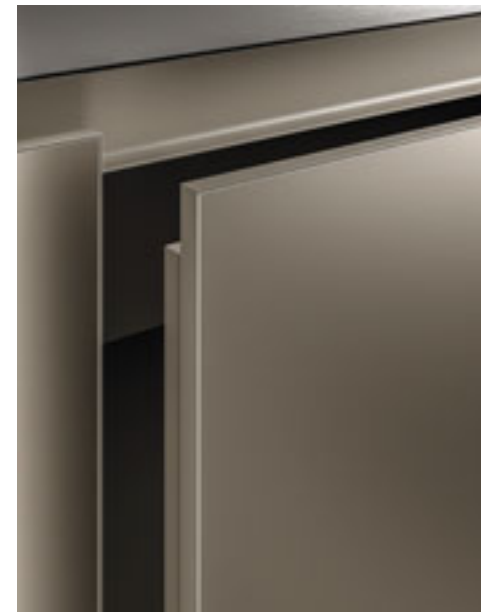

Opaco effetto metallo
nella foto: anta effetto metallo lucem, gola e telaio
laccato metallo lucem
Metal effect matt
in photo: lucem metal effect door, lucem metal
lacquered groove strip and frame



Lucido effetto metallo
nella foto: anta browngold, gola e telaio laccato
effetto metallo satinato browngold
Metal effect gloss
in photo: browngold door, browngold satined
metal effect lacquered groove strip and frame



Acciaio satinato
nella foto: ante basi hi-melamine noce canyon
canneté, profilo e gola laccato metallo lucem
Satinated steel
in photo: canneté canyon walnut hi-melamine
base unit doors, lucem metal lacquered profile and
groove strip



Stone+ nevada
nella foto: ante basi stone+ nevada rigato, telaio e
gola laccato metallo lucem
Nevada stone+
in photo: striped nevada stone+ base unit doors,
lucem metal lacquered frame and groove strip

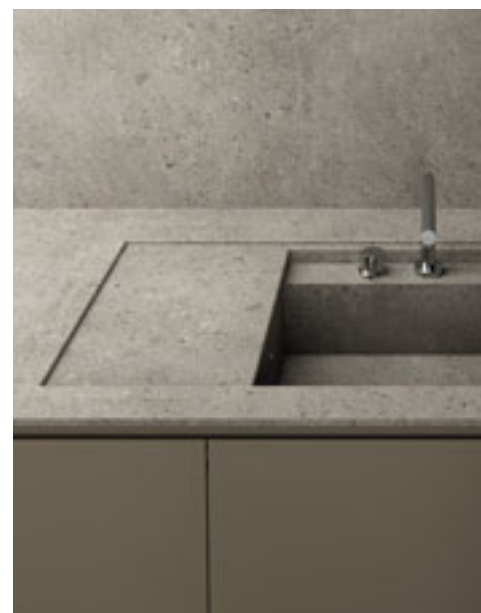

Stone+ cervino tarmac
nella foto: ante basi, profilo e gola laccato zero
gloss moka
Cervino tarmac stone+
in photo: moka zero gloss lacquered base unit
doors, profile and groove strip



Fenix
nella foto: ante basi Fenix beige arizona, profilo e
gola laccato flat matt beige arizona
in photo: arizona beige Fenix base unit doors,
arizona beige flat matt lacquered profile and
groove strip



Iconcrete
nella foto: ante basi hi-melamine rovere teide,
profilo e gola laccato metallo lucem
in photo: teide oak hi-melamine base unit doors,
lucem metal lacquered profile and groove strip



Quartz
nella foto: piano quartz globe grey opaco, ante basi
vetro opaco grigio artico, telaio e gola laccato flat
matt grigio artico
in photo: matt globe grey quartz worktop, arctic
grey matt glass base unit doors, arctic grey flat matt
lacquered frame and groove strip



Olmo namib
nella foto: attrezzatura interna olmo namib, top marmo
calacatta oro vagli, coprifianco laccato zero gloss
Namib elm
in photo: namib elm internal fittings, calacatta oro
vagli marble worktop, zero gloss lacquered side
facing panel



Noce canyon
nella foto: attrezzatura interna olmo namib, top e
coprifianco gres rock bahama beige
Canyon walnut
in photo: namib elm internal fittings, rock bahama
beige worktop and side facing panel



Rovere teide
nella foto: attrezzatura interna olmo namib, top e
coprifianco Fenix
Teide oak
in photo: namib elm internal fittings, Fenix worktop
and side facing panel



Caucaso
nella foto: attrezzatura interna olmo namib, top e
coprifianco acciaio satinato
Caucasus
in photo: namib elm internal fittings, satinated steel
worktop and side facing panel



Plateau alluminio lucem
nella foto: divisori impiallacciato rovere nordic
Lucem aluminium tray
in photo: nordic oak veneer partitions



Plateau alluminio peltrox
nella foto: divisori impiallacciato rovere nordic
Peltrox aluminium tray
in photo: nordic oak veneer partitions

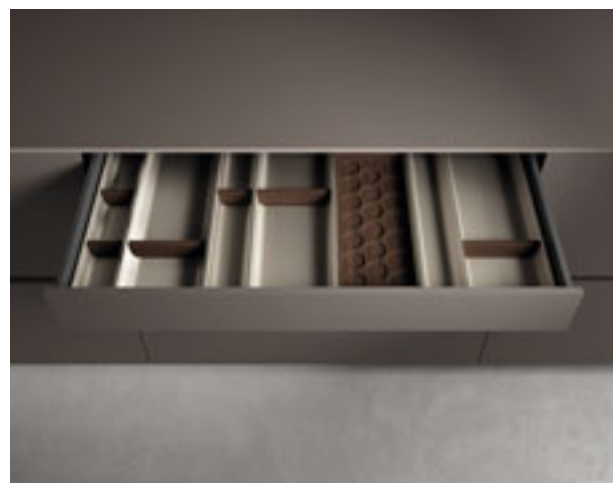

Plateau alluminio lucem
nella foto: divisori impiallacciato rovere termotrattato
Lucem aluminium tray
in photo: heat-treated oak veneer partitions



Plateau alluminio peltrox
nella foto: divisori impiallacciato rovere termotrattato
Peltrox aluminium tray
in photo: heat-treated oak veneer partitions



nella foto: struttura laccato flat matt grigio efeso e vetro grigio trasparente, accessori impiallacciato rovere nordic, top Fenix grigio efeso
in photo: ephesus grey flat matt lacquered structure and clear grey glass, nordic oak veneered fittings, ephesus grey Fenix worktop



nella foto: struttura laccato flat matt grigio artico, accessori impiallacciato rovere nordic, top marmo
in photo: arctic grey flat matt lacquered structure, nordic oak veneered fittings, marble worktop



nella foto: struttura laccato metallo lucem e vetro riflettente chiaro, accessori impiallacciato rovere termotrattato, top stone+nevada
in photo: lucem metal lacquered and clear reflective glass structure, heat-treated oak veneered accessories, nevada stone+worktop



nella foto: struttura laccato metallo lucem, accessori impiallacciato rovere termotrattato, top acciaio
in photo: lucem metal lacquered structure, heat-treated oak veneered accessories, steel worktop

Cromie
Colour shades



Laccato effetto metallo satinato
nella foto: boiserie ed elementi a giorno titanium,
spondina laccato metallo lucem
Satinated metal effect lacquered
in photo: titanium boiserie panel and open
elements, lucem metal lacquered edge fence



Laccato effetto metallo mirror
nella foto: boiserie ed elementi a giorno bronzo,
spondina laccato metallo lucem
Mirror metal effect lacquered
in photo: bronze boiserie panel and open elements,
lucem metal lacquered edge fence



Laccato flat matt
nella foto: boiserie ed elementi a giorno grigio
island, spondina laccato metallo lucem
Flat matt lacquered
in photo: island grey boiserie panel and open
elements, lucem metal lacquered edge fence



Hi-melamine
nella foto: boiserie ed elementi a giorno grigio
fossile, spondina laccato metallo lucem
in photo: fossil grey boiserie panel and open
elements, lucem metal lacquered edge fence



Fenix
nella foto: boiserie ed elementi a giorno nero ingo,
spondina laccato metallo lucem
in photo: ingo black boiserie panel and open
elements, lucem metal lacquered edge fence

Impiallacciato
Veneer

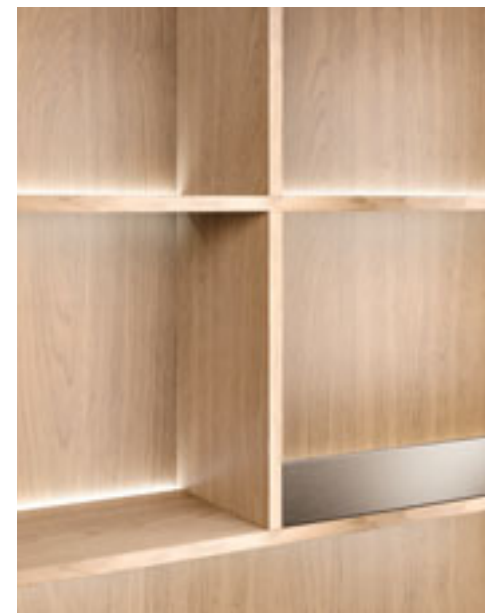

Rovere nordic
nella foto: spondina laccato metallo lucem
Nordic oak
in photo: lucem metal lacquered edge fence



Olmo caramel
nella foto: spondina laccato metallo lucem
Caramel elm
in photo: lucem metal lacquered edge fence



Noce canaletto
nella foto: spondina laccato metallo lucem
Canaletto walnut
in photo: lucem metal lacquered edge fence



Rovere cenere
nella foto: spondina laccato metallo lucem
Ash grey oak
in photo: lucem metal lacquered edge fence



Rovere termotrattato
nella foto: spondina laccato metallo lucem
Heat-treated oak
in photo: lucem metal lacquered edge fence



Rovere nero poro aperto
nella foto: spondina laccato metallo lucem
Open pore black oak
in photo: lucem metal lacquered edge fence

Hi-melamine effetto legno
Wood effect hi-melamine

Olmo namib
nella foto: spondina laccato metallo lucem
Namib elm
in photo: lucem metal lacquered edge fence



Noce canyon
nella foto: spondina laccato metallo lucem
Canyon walnut
in photo: lucem metal lacquered edge fence

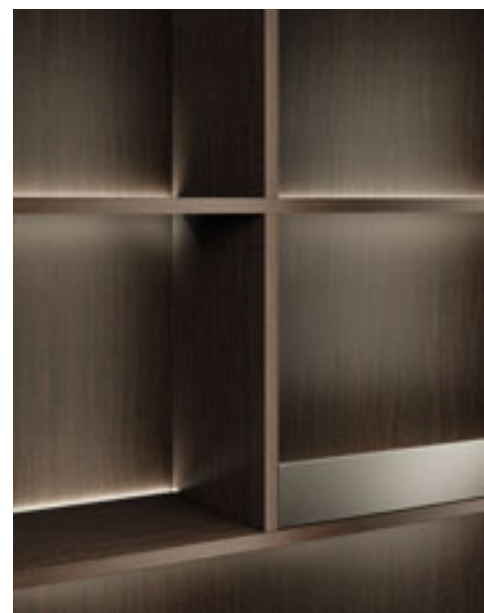

Rovere teide
nella foto: spondina laccato metallo lucem
Teide oak
in photo: lucem metal lacquered edge fence



Caucaso
nella foto: spondina laccato metallo lucem
Caucasus
in photo: lucem metal lacquered edge fence



Olmo namib canneté
nella foto: spondina laccato metallo lucem
Canneté namib elm
in photo: lucem metal lacquered edge fence



Noce canyon canneté
nella foto: spondina laccato metallo lucem
Canneté canyon walnut
in photo: lucem metal lacquered edge fence



Rovere teide canneté
nella foto: spondina laccato metallo lucem
Canneté teide oak
in photo: lucem metal lacquered edge fence

con profilo Zed
with Zed profile



Laccato flat matt
nella foto: profilo e anta grigio nuange
Flat matt lacquered
in photo: nuage grey profile and door



Laccato effetto metallo mirror
nella foto: profilo e anta titanium
Mirror metal effect lacquered
in photo: titanium profile and door

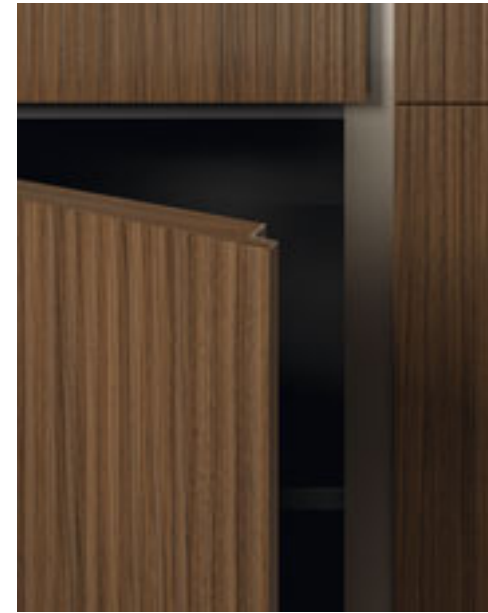

Laccato effetto metallo satinato
nella foto: profilo lucem e anta hi-melamine noce
canyon canneté
Satinated metal effect lacquered
in photo: lucem profile and canneté canyon walnut
hi-melamine door

con profilo Stream
with Stream profile



Laccato zero gloss
nella foto: profilo e anta grigio bromo
Zero gloss lacquered
in photo: bromine grey profile and door

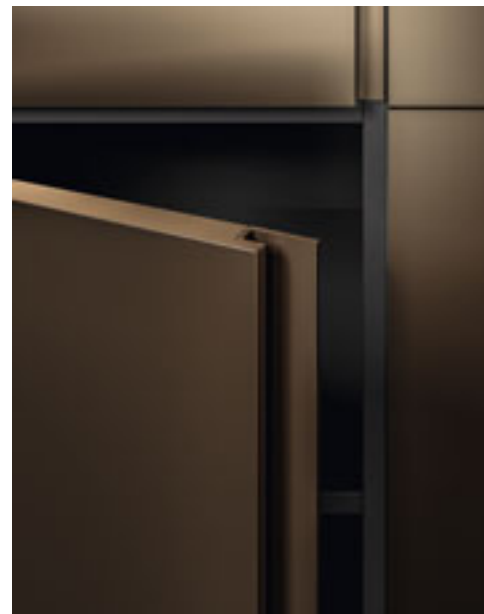

Laccato effetto metallo mirror
nella foto: profilo e anta browngold
Mirror metal effect lacquered
in photo: browngold profile and door

Lever



Laccato zero gloss
nella foto: maniglia e anta grigio efeso
Zero gloss lacquered
in photo: ephesus grey handle and door



Laccato effetto metallo mirror
nella foto: maniglia e anta titanium
Mirror metal effect lacquered
in photo: titanium handle and door



Laccato effetto metallo satinato
nella foto: maniglia lucem e anta impiallacciato
rovere nordic
Satinated metal effect lacquered
in photo: lucem handle and nordic oak veneered
door

Trace



Laccato flat matt
nella foto: maniglia e anta ghisa
Flat matt lacquered
in photo: cast-iron grey handle and door



Laccato effetto metallo satinato
nella foto: maniglia ferrum, inserto e anta
impiallacciato rovere nero poro aperto
Satinated metal effect lacquered
in photo: ferrum handle and open pore black oak
veneered insert and door

Hi-melamine effetto legno
Wood effect hi-melamine



Olmo namib
nella foto: cornice laccato effetto metallo satinato
umber, ante impiallacciato rovere termotrattato
Namib elm
in photo: umber satined metal effect lacquered
surround, heat-treated oak veneered doors



Noce canyon
nella foto: cornice laccato effetto metallo satinato
bronzo, ante hi-melamine noce canyon canneté
Canyon walnut
in photo: bronze satined metal effect lacquered
surround, canneté canyon walnut hi-melamine
doors

Laccato
Lacquered



Laccato flat matt
nella foto: sistema grigio island, cornice e ante
laccato flat matt whitemoon
Flat matt lacquered
in photo: island grey system, whitemoon flat matt
lacquered surround and doors



Rovere teide
nella foto: cornice e ante laccato effetto metallo
satinato titanium
Teide oak
in photo: titanium satined metal effect lacquered
surround and doors



Caucaso
nella foto: cornice e ante laccato zero gloss grigio
island
Caucasus
in photo: island grey zero gloss lacquered surround
and doors



Effetto metallo satinato titanium
nella foto: cornice titanium, ante impiallacciate
rovere termotrattato
Titanium satined metal effect
in photo: titanium surround, heat-treated oak
veneered doors

Hi-melamine effetto legno
Wood effect hi-melamine



Olmo namib
nella foto: fondo ecopelle bordeaux
Namib elm
in photo: bordeaux eco-leather bottom



Noce canyon
nella foto: fondo ecopelle bordeaux
Canyon walnut
in photo: bordeaux eco-leather bottom



Rovere teide
nella foto: fondo ecopelle visone
Teide oak
in photo: mink eco-leather bottom



Caucaso
nella foto: fondo ecopelle brownish
Caucasus
in photo: brownish eco-leather bottom

Hi-melamine effetto legno
Wood effect hi-melamine



Olmo namib
nella foto: anta, ripiani e fianco in vetro riflettente
chiaro, telaio e profili laccato metallo lucem
Namib elm
in photo: clear reflective glass door, shelves and
side panel, lucem metal lacquered frame and
profiles



Olmo namib
nella foto: anta, ripiani e fianco in vetro grigio
trasparente, telaio e profili laccato metallo lucem
Namib elm
in photo: clear grey glass door, shelves and side
panel, lucem metal lacquered frame and profiles



Noce canyon
nella foto: anta, ripiani e fianco in vetro grigio
trasparente, telaio e profili laccato metallo satinato
bronzo
Canyon walnut
in photo: clear grey glass door, shelves and side
panel, bronze satined metal lacquered frame and
profiles



Rovere teide
nella foto: anta, ripiani e fianco in vetro grigio
trasparente, telaio e profili laccato metallo satinato
titanium
Teide oak
in photo: clear grey glass door, shelves and side
panel, titanium satined metal lacquered frame and
profiles



Caucaso
nella foto: anta, ripiani e fianco in vetro riflettente
fumé, telaio e profili laccato zero gloss nero
Caucasus
in photo: smoky grey reflective glass door, shelves
and side panel, black zero gloss metal lacquered
frame and profiles

Hi-melamine

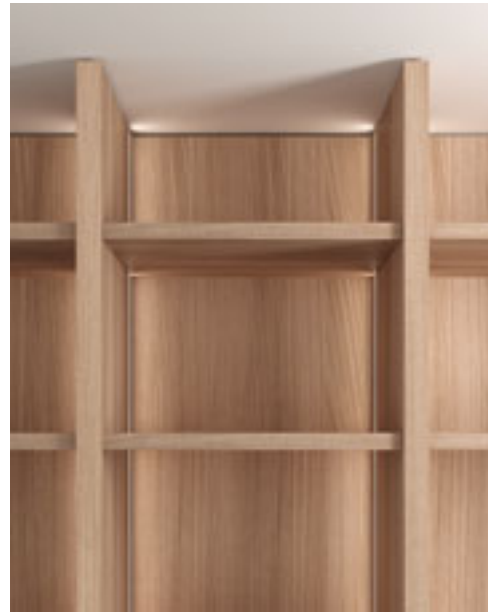

nella foto: schienale, spalle e ripiani olmo namib
in photo: namib elm back panel, uprights and shelves



nella foto: schienale e ripiani beige phoenix, spalle olmo namib
in photo: phoenix beige back panel and shelves, namib elm uprights

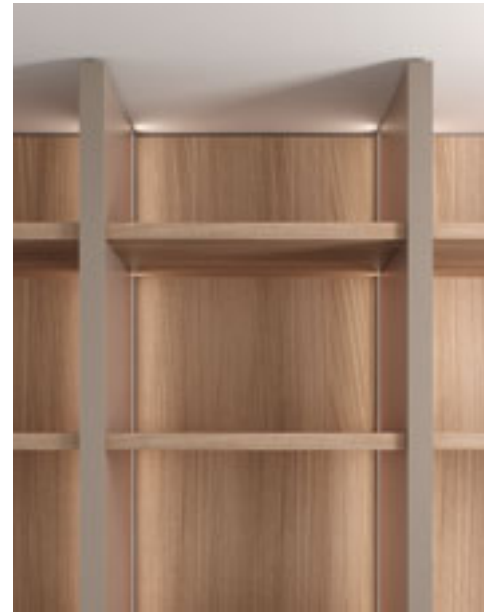

nella foto: schienale e ripiani olmo namib, spalle beige phoenix
in photo: namib elm back panel and shelves, phoenix beige uprights

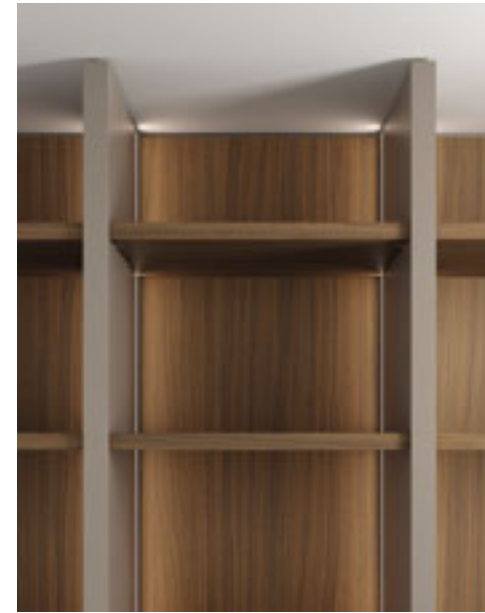

nella foto: schienale e ripiani noce canyon, spalle beige phoenix
in photo: canyon walnut back panel and shelves, phoenix beige uprights

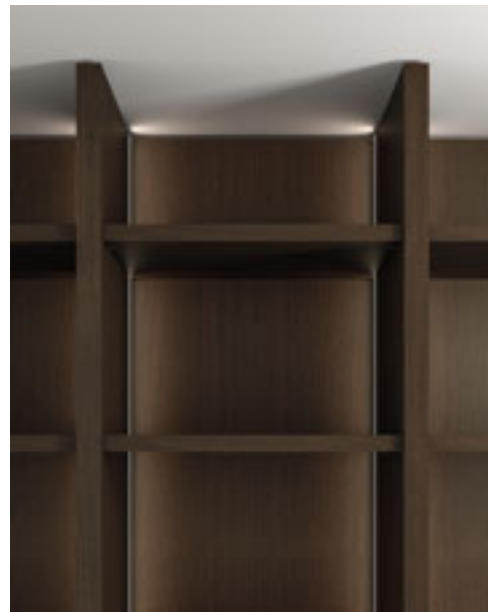

nella foto: schienale, spalle e ripiani rovere teide
in photo: teide oak back panel, uprights and shelves



nella foto: schienale e ripiani beige phoenix, spalle rovere teide
in photo: phoenix beige back panel and shelves, teide oak uprights

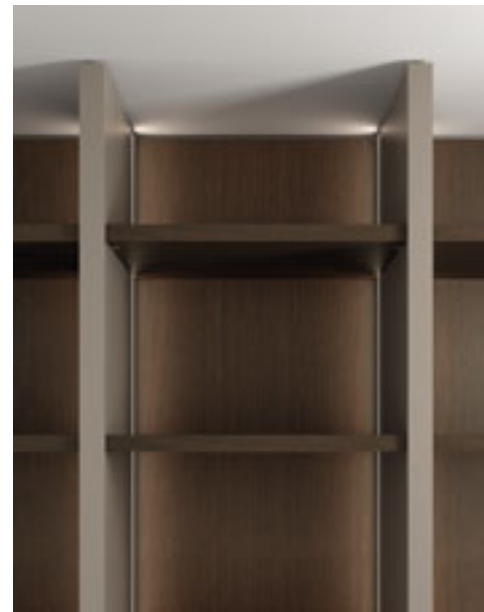

nella foto: schienale e ripiani rovere teide, spalle beige phoenix
in photo: teide oak back panel and shelves, phoenix beige uprights



Ripiano fisso
nella foto: telaio in alluminio laccato metallo lucem,
fondo vetro grigio trasparente

Fixed shelf
in photo: lucem metal lacquered aluminium frame,
clear grey glass shelf



Ripiano estraibile
nella foto: telaio in alluminio laccato metallo lucem,
fondo vetro grigio trasparente

Pull-out shelf
in photo: lucem metal lacquered aluminium frame,
clear grey glass shelf

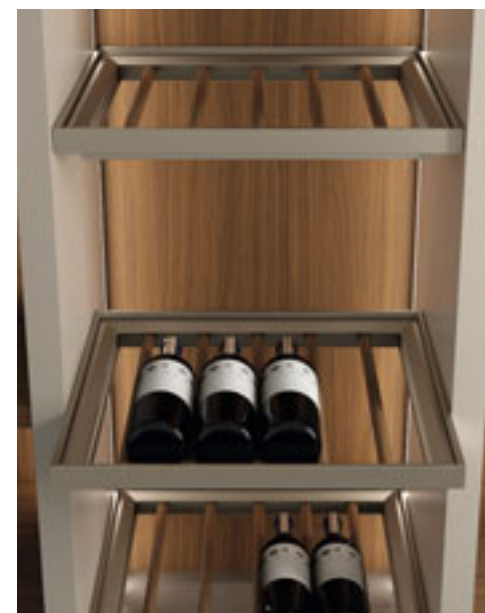

Ripiano estraibile portabottiglie
nella foto: telaio in alluminio laccato metallo lucem,
pioli in massello noce canyon

Pull-out bottle rack
in photo: lucem metal lacquered aluminium frame,
canyon walnut pegs



Cassetto estraibile 4 lati
nella foto: sponde e frontale in alluminio laccato
metallo lucem, fondo in hi-melamine rovere teide

4-sided pull-out drawer
in photo: lucem metal lacquered aluminium sides
and front, teide oak hi-melamine bottom



Cassetto estraibile frontale vetro
nella foto: sponde in alluminio laccato metallo
lucem, frontale grigio trasparente, fondo in
hi-melamine rovere teide

Glass-fronted pull-out drawer
in photo: lucem metal lacquered aluminium sides,
clear grey front, teide oak hi-melamine bottom



Vassoio estraibile
nella foto: telaio e sponde in alluminio laccato
metallo lucem, fondo in hi-melamine olmo namib

Pull-out tray
in photo: lucem metal lacquered aluminium frame
and sides, namib elm hi-melamine bottom



Ripiano estraibile porta sacca
nella foto: sacca in tessuto metropolitan, telaio
laccato metallo lucem

Pull-out bag holder shelf
in photo: metropolitan fabric bag, lucem metal
lacquered frame



Porta abiti
nella foto: tubo laccato metallo lucem

Clothes rail
in photo: lucem metal lacquered rail



Ripiano estraibile porta scarpe
nella foto: fondo ecopelle visone, telaio laccato
metallo lucem

Pull-out shoe rack
in photo: mink eco-leather shelf, lucem metal
lacquered frame

La versatilità progettuale di Sign è sottolineata dall'ampiezza di gamma dei materiali e delle finiture previste. Dalle soluzioni più essenziali come i melaminici e i laccati opachi, a quelle più ricercate come le laccature e i vetri metallizzati, fino alle essenze lignee, i marmi e le pietre naturali. Un insieme che all'estrema varietà associa una coerenza estetica generale, per garantire sempre la massima libertà di scelta.

Sign's interior design versatility is highlighted by the range of materials and finishes available. From the most basic solutions such as melamines and matt lacquered finishes to the more sophisticated lacquers and metallised glasses, through to natural woods, marbles and stones. An assortment that combines extreme variety with an overall aesthetic coherence, to guarantee the utmost freedom of choice every time.



Laccati effetto metallo mirror *
Mirror metal effect lacquered

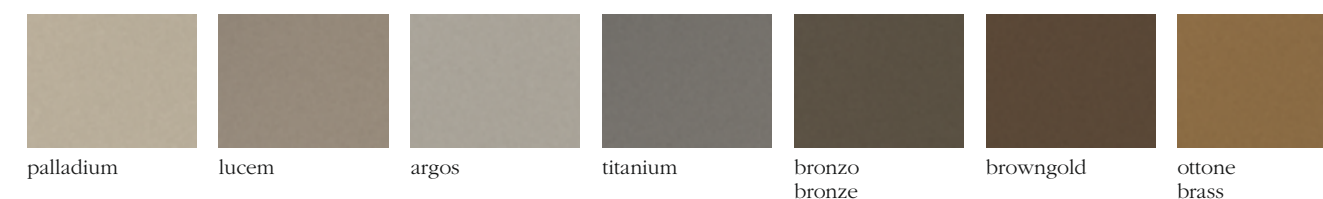

Laccati effetto metallo satinato *
Satinated metal effect lacquered



* finitura con vernice antibatterica
* antibacterial paint finish

Fenix ntm™ con bordo laser
Fenix ntm™, laser edge

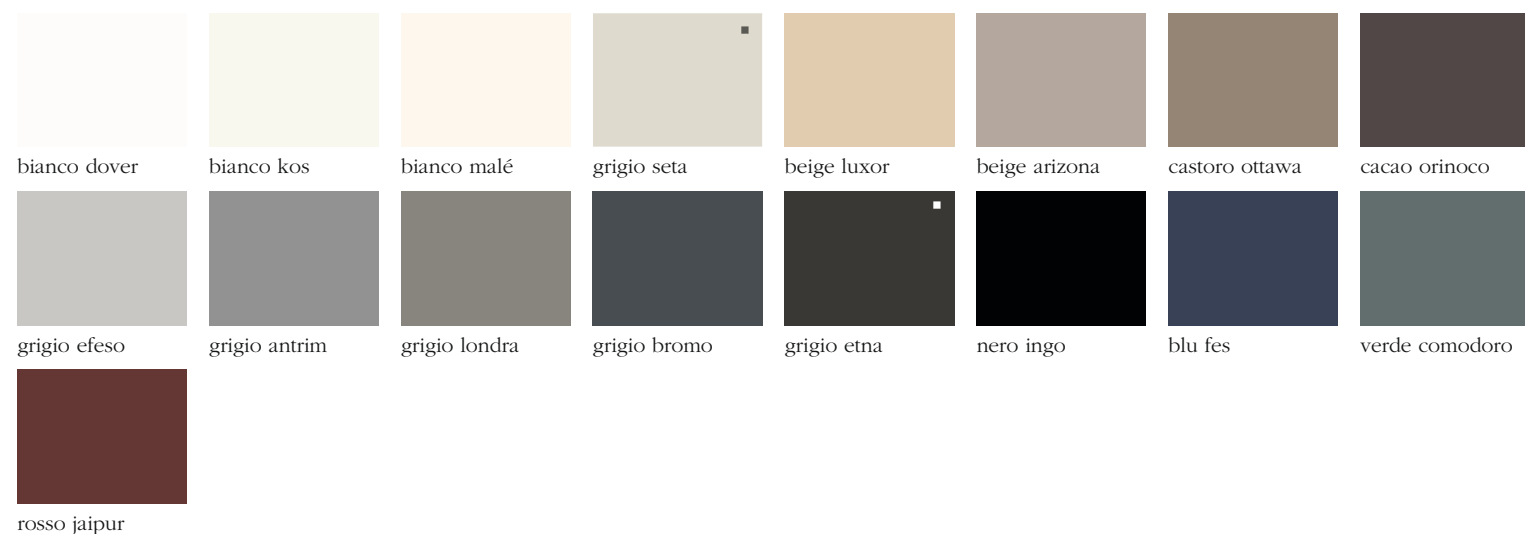

Hi-melamine effetto legno con bordo abs
Wood effect Hi-melamine, abs edge



Laminato opaco e lucido con bordo laser
Matt and glossy laminate, laser shaped edge



Hi-melamine bordo laser
Hi-melamine, laser-shaped edge



Laminato materico monocolore con bordo laser
Monochrome textured laminate, laser edge



Hi-melamine effetto resina con bordo abs
Resin-look colours Hi-melamine, abs edge

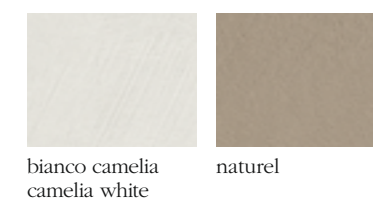

Laminato materico effetto pietra con bordo laser
Stone effect textured laminate, laser edge



Hi-melamine effetto metallo con bordo abs
Metal-look colours Hi-melamine, abs edge

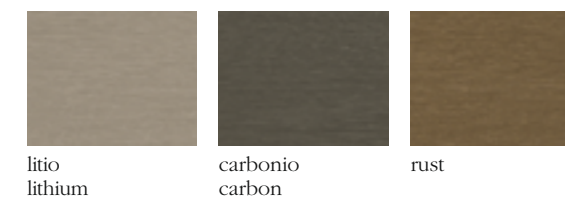

Legno massello "Deluxe"
"Deluxe" solid wood

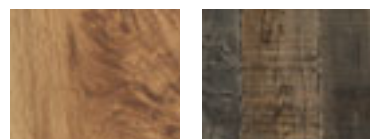

rovere quercus
quercus oak

rovere vintage
vintage oak

Impiallacciato legno
Wood veneer



olmo caramel
caramel elm

rovere termotrattato
heat-treated oak

olmo carob
carob elm

Impiallacciato antico
Antique-effect veneer



rovere terra d'ombra nodato
knotted terra d'ombra oak

Legno impiallacciato Zero Gloss
Zero Gloss veneered wood



rovere nordic
smooth
smooth nordic oak

rovere light
light oak

rovere duna
dune oak

rovere titanio
titanium oak

noce canaletto
canaletto walnut

rovere termotrattato
smooth
smooth heat-treated oak

rovere cenere
ash oak

rovere nero
poro aperto
open-pore black oak

Stone+



velour white dove

vega

sign smoky

rock bahama beige

nevada canneté

cervino tarmac

piasentina polaris

mercury brown

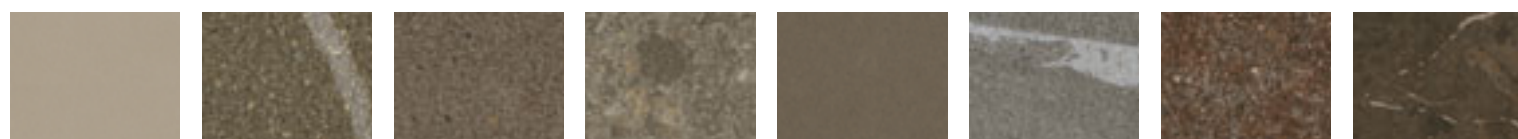

velour autumn

piasentina antares

thunder grey

antea

gray land

sirio

porfido kepler

kalypso

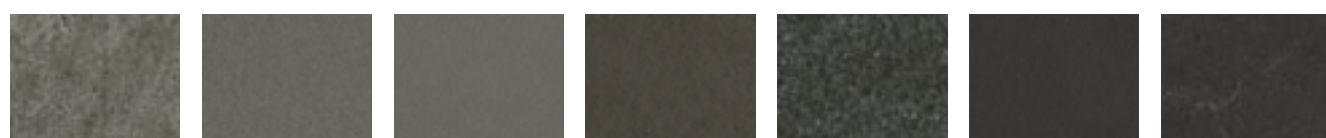

ocean smoky

ground

velour smoky

humus

cardoso orion

velour night

twister night

Gres porcellanato Laminam
Porcelain stoneware

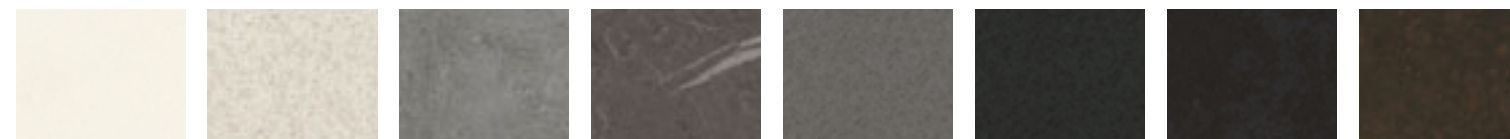

bianco assoluto

calce bianco

pietra savoia perla

pietra grey

calce antracite

calce nero

ossido nero

ossido bruno

Vetro lucido e opaco, retro-verniciato
Gloss and matt glass finishes with back-painting



ghiaccio
ice

bianco
white

grigio efeso

grigio rugiada
dew grey

linum

limo
silt

grigio paloma
paloma grey

moka
mocha



grigio artico
arctic grey

grigio ghisa
cast-iron grey

grigio bromo

nero
black

Vetro lucido e opaco, retro-verniciato effetto metallo
Gloss and matt glass finishes with metal-effect backpainted

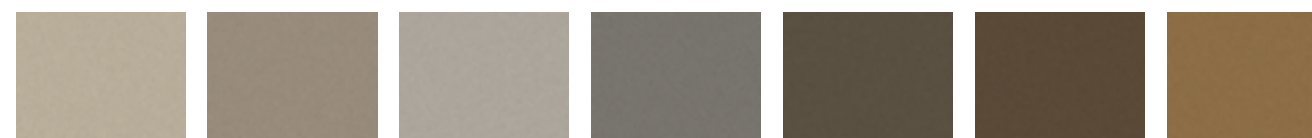

palladium

luce

argos

titanium

bronzo
bronze

browngold

ottone
brass

Armadi e pensili "View", Pensili "In line" / View cupboards and wall units, In Line wall units

Finiture vetro lucido e opaco, retro-verniciato
Gloss and matt glass finishes with back-painting



grigio trasparente
clear grey

riflettente chiaro
clear reflective

bronzo trasparente
clear bronze

riflettente fumé
tinted reflective

I colori non sempre corrispondono a quelli reali per comprensibili motivi di stampa. Colori e tonalità si possono visionare presso i Punti Vendita, direttamente su prodotti e campionari.

For obvious reasons relating to printing methods, colours are not always exactly as shown. Colours and shades can be viewed at our Dealers, directly on products and samples.

Tecnica e funzione. Nella sezione dedicata agli architetti, grazie al supporto dei disegni tecnici, tutte le risposte alle specifiche esigenze progettuali. Modularità, caratteristiche peculiari di ogni elemento, fattibilità e vincoli. Massima libertà compositiva per la cucina ideale.

Technical and functional excellence. The section for architects includes technical drawings and provides responses to all specific design needs. Modularity, individual characteristics of each element, feasibility and restrictions. The greatest freedom of composition for the ideal kitchen.

Indice Contents	
Modularità Modularity	174
Vetrine View View Glass-Fronted Units	184
Scaffali boiserie Stay Stay Boiserie Shelves	188
Armadi e Colonne In Space In Space Cupboards and Tall Units	194
Armadio Double Indoor Double Indoor Cupboard	196
Armadio Indoor Indoor Cupboard	199
Colonne, vani e pensili a giorno Daylight Daylight tall, open and wall units	200
Move-on Plus e Move-On Move-on Plus and Move-On	206
Able	212
Zona cottura Mdi Induction Mdi Induction cooking zone	218
Piano cottura Gourmet Gourmet Hob	220
Pensile In Line In Line wall unit	221
Canale Bridge Bridge tidy system	222
Cappa Hood in line Hood in line hood	224
Cappa K-System K-System hood	226
Attrezzature Surf Surf equipment	230
Mensola e profilo Order Order shelf and rail	232
Tavolo Line table Line Table	234
Back System	238

MODULARITÀ BASI, PENSILI vista frontale
BASE CABINETS, WALL CABINETS MODULARITY front view

VERSIONE CON GOLA
VERSION WITH GROOVE STRIP

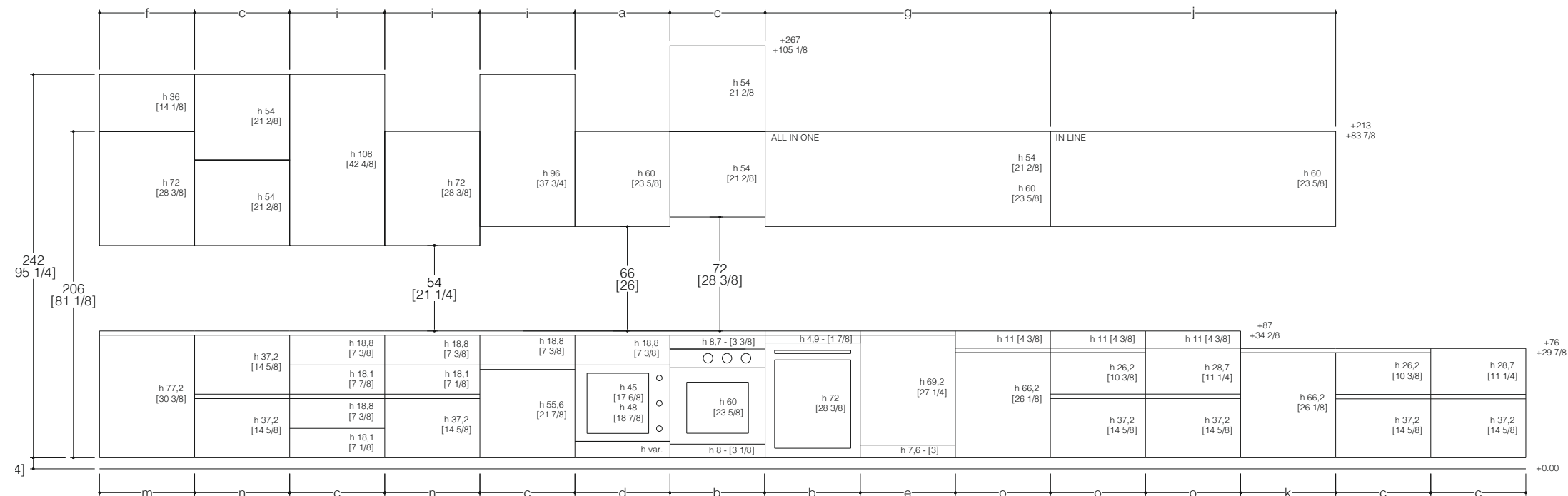

- LEGENDA (cm)
- a = 15-20-30-40-45-60-80-90-120cm
 - b = 60cm
 - c = 30-45-60-75-90-120cm
 - d = 60-90cm
 - e = 45-60cm
 - f = 15-20-30-45-60-90-120cm
 - g = 120-150-180-210-240cm
 - h = 30-45-60-90cm
 - i = 15-20-30-40-45-60-80-90cm
 - j = 60-90-120-150-180cm
 - k = 15-30-45-60-90-120cm
 - l = 60-90-120cm
 - m = 15-20-30-40-45-60-75-80-90-120-150cm
 - n = 30-45-60-90-120cm
 - o = 45-60-75-90-120cm
 - p = 30-45-60-75-90cm

- KEY TO DIMENSION (inches)
- a = 5 7/8 - 7 7/8 - 11 6/8 - 15 6/8 - 17 6/8 - 23 5/8 - 31 4/8 - 35 3/8 - 47 2/8
 - b = 23 5/8
 - c = 11 6/8 - 17 6/8 - 23 5/8 - 35 3/8 - 47 2/8
 - d = 23 5/8 - 35 3/8
 - e = 17 6/8 - 23 5/8
 - f = 5 7/8 - 7 7/8 - 11 6/8 - 17 6/8 - 23 5/8 - 35 3/8 - 47 2/8
 - g = 47 2/8 - 59 - 70 7/8 - 82 5/8 - 94 4/8
 - h = 11 6/8 - 17 6/8 - 23 5/8 - 35 3/8
 - i = 5 7/8 - 7 7/8 - 11 6/8 - 15 6/8 - 17 6/8 - 23 5/8 - 31 4/8 - 35 3/8
 - j = 23 5/8 - 35 3/8 - 47 2/8 - 59 - 70 7/8
 - k = 5 7/8 - 11 6/8 - 17 6/8 - 23 5/8 - 35 3/8 - 47 2/8
 - l = 23 5/8 - 35 3/8 - 47 2/8
 - m = 5 7/8 - 7 7/8 - 11 6/8 - 15 6/8 - 17 6/8 - 23 5/8 - 29 1/2 - 31 4/8 - 35 3/8 - 47 2/8 - 59
 - n = 11 6/8 - 17 6/8 - 23 5/8 - 35 3/8 - 47 2/8
 - o = 17 6/8 - 23 5/8 - 29 1/2 - 35 3/8 - 47 1/4
 - p = 11 6/8 - 17 6/8 - 23 5/8 - 29 1/2 - 35 3/8

MODULARITÀ BASI SENZA GOLA vista frontale
BASE CABINETS WITHOUT GROOVE STRIP MODULARITY front view

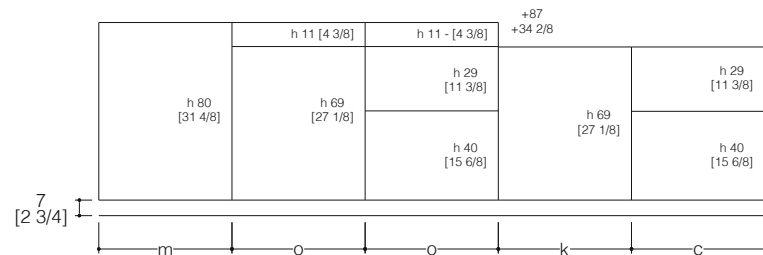

MODULARITÀ BASI SOSPESE CON GOLA vista frontale
WALL-MOUNTED BASE CABINETS MODULARITY front view

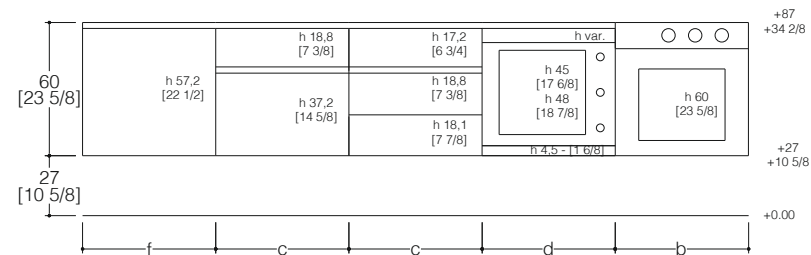

MODULARITÀ BASI, PENSILI vista laterale
BASE CABINETS, WALL CABINETS MODULARITY side view

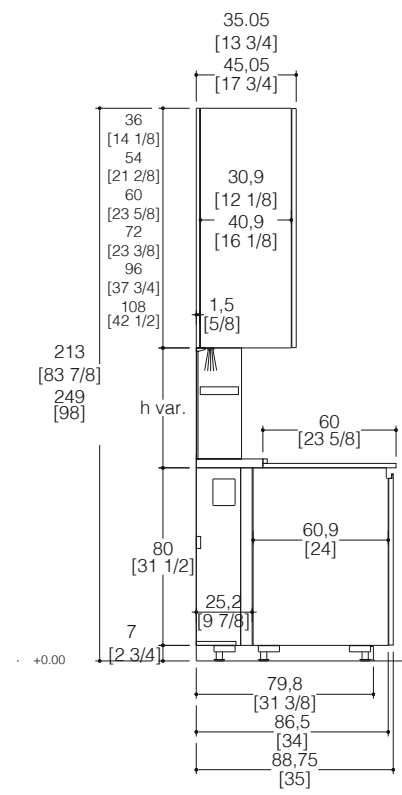
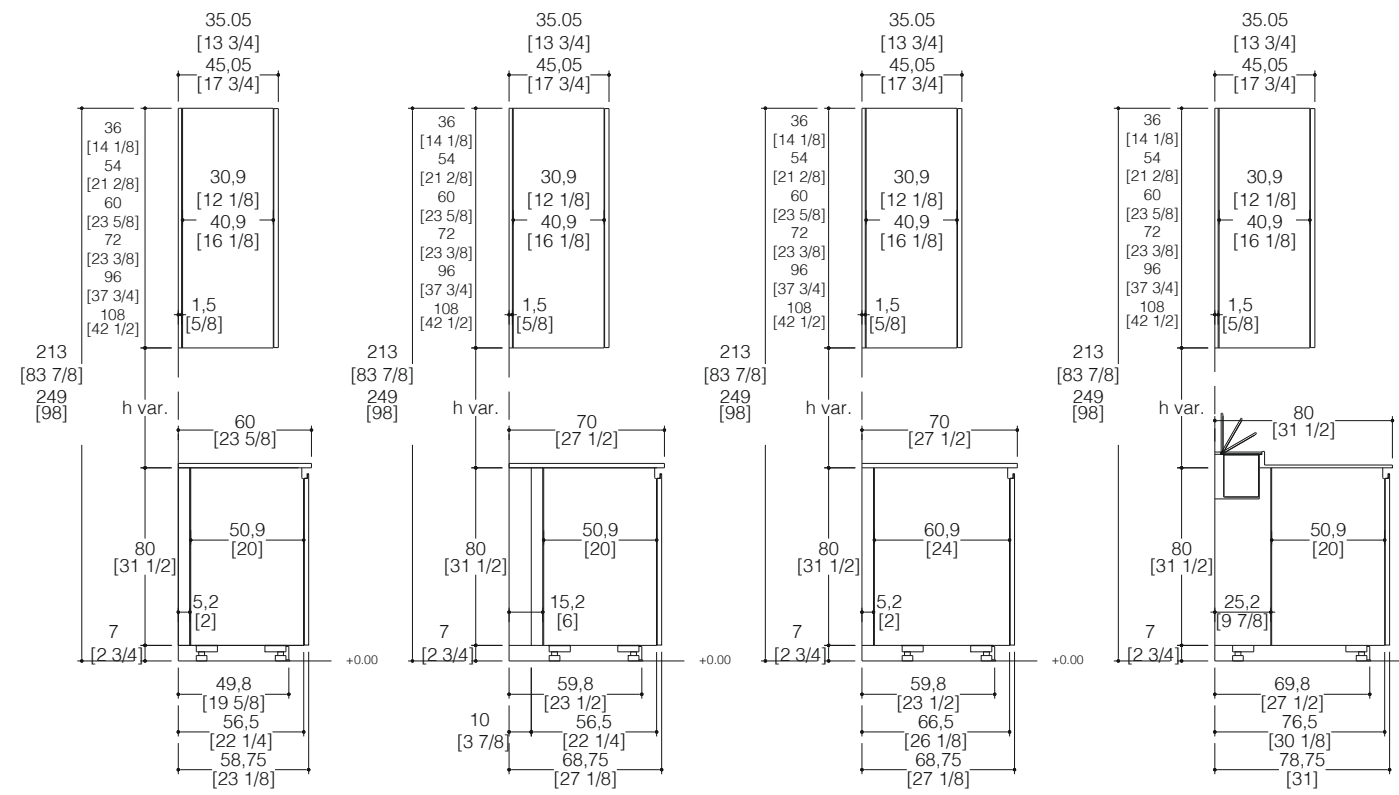

- LEGENDA (cm)
- a = 15-20-30-40-45-60-80-90-120cm
 - b = 60cm
 - c = 30-45-60-75-90-120cm
 - d = 60-90cm
 - e = 45-60cm
 - f = 15-20-30-45-60-90-120cm
 - g = 120-150-180-210-240cm
 - h = 30-45-60-90cm
 - i = 15-20-30-40-45-60-80-90cm
 - j = 60-90-120-150-180cm
 - k = 15-30-45-60-90-120cm
 - l = 60-90-120cm
 - m = 15-20-30-40-45-60-75-80-90-120-150cm
 - n = 30-45-60-90-120cm
 - o = 45-60-75-90-120cm
 - p = 30-45-60-75-90cm

- KEY TO DIMENSION (inches)
- a = 5 7/8 - 7 7/8 - 11 6/8 - 15 6/8 - 17 6/8 - 23 5/8 - 31 4/8 - 35 3/8 - 47 2/8
 - b = 23 5/8
 - c = 11 6/8 - 17 6/8 - 23 5/8 - 35 3/8 - 47 2/8
 - d = 23 5/8 - 35 3/8
 - e = 17 6/8 - 23 5/8
 - f = 5 7/8 - 7 7/8 - 11 6/8 - 17 6/8 - 23 5/8 - 35 3/8 - 47 2/8
 - g = 47 2/8 - 59 - 70 7/8 - 82 5/8 - 94 4/8
 - h = 11 6/8 - 17 6/8 - 23 5/8 - 35 3/8
 - i = 5 7/8 - 7 7/8 - 11 6/8 - 15 6/8 - 17 6/8 - 23 5/8 - 31 4/8 - 35 3/8
 - j = 23 5/8 - 35 3/8 - 47 2/8 - 59 - 70 7/8
 - k = 5 7/8 - 11 6/8 - 17 6/8 - 23 5/8 - 35 3/8 - 47 2/8
 - l = 23 5/8 - 35 3/8 - 47 2/8
 - m = 5 7/8 - 7 7/8 - 11 6/8 - 15 6/8 - 17 6/8 - 23 5/8 - 29 1/2 - 31 4/8 - 35 3/8 - 47 2/8 - 59
 - n = 11 6/8 - 17 6/8 - 23 5/8 - 35 3/8 - 47 2/8
 - o = 17 6/8 - 23 5/8 - 29 1/2 - 35 3/8 - 47 1/4
 - p = 11 6/8 - 17 6/8 - 23 5/8 - 29 1/2 - 35 3/8

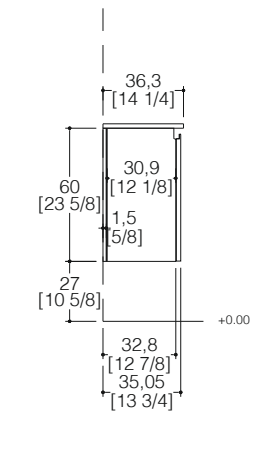
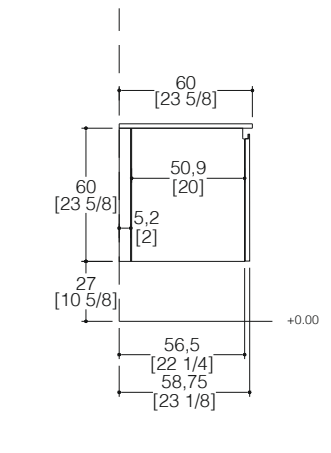
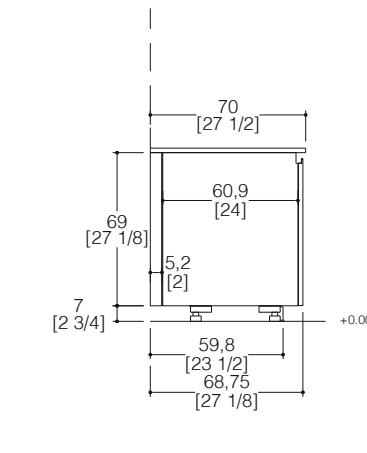
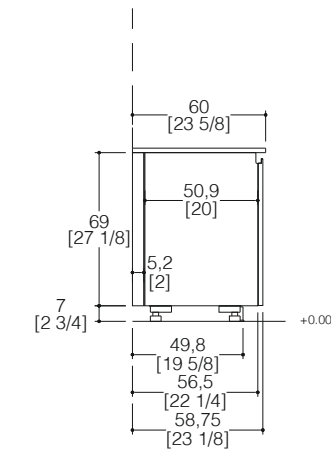
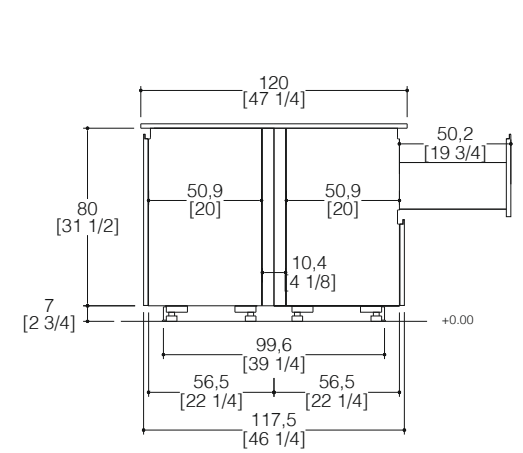
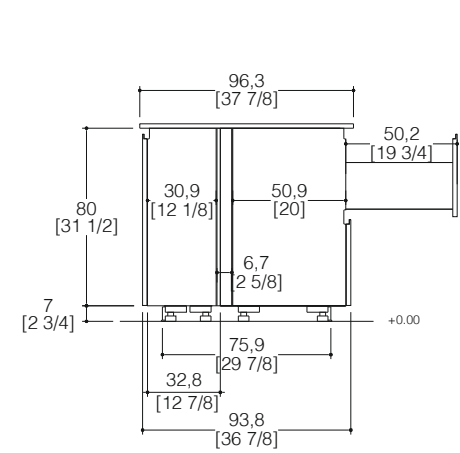

MODULARITÀ ARMADI E COLONNE vista frontale e laterale
TALL UNITS & CUPBORDS MODULARITY front view and side view

VERSIONE CON GOLA
VERSION WITH GROOVE STRIP

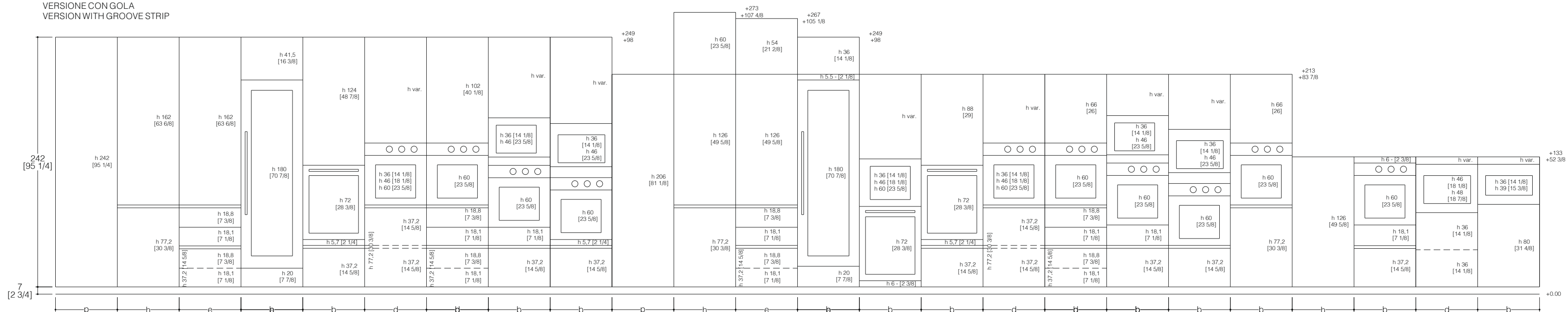

LEGENDA (cm)
 a = 15-20-30-40-45-60-80-90-120cm
 b = 60cm
 c = 30-45-60-75-90-120cm
 d = 60-90cm
 e = 45-60cm
 f = 15-20-30-45-60-90-120cm
 g = 120-150-180-210-240cm
 h = 30-45-60-90cm
 i = 15-20-30-40-45-60-80-90cm
 j = 60-90-100-105.5-120-129-150-180cm
 k = 15-30-45-60-90-120cm
 l = 60-90-120cm
 m = 15-20-30-40-45-60-75-80-90-120-150cm
 n = 30-45-60-90-120cm
 o = 45-60-75-90-120cm
 p = 30-45-60-75-90cm

KEY TO DIMENSION (inches)
 a = 5 7/8 - 7 7/8 - 11 6/8 - 15 6/8 - 17 6/8 - 23 5/8 - 31 4/8 - 35 3/8 - 47 2/8
 b = 23 5/8
 c = 11 6/8 - 17 6/8 - 23 5/8 - 35 3/8 - 47 2/8
 d = 23 5/8 - 35 3/8
 e = 17 6/8 - 23 5/8
 f = 5 7/8 - 7 7/8 - 11 6/8 - 17 6/8 - 23 5/8 - 35 3/8 - 47 2/8
 g = 47 2/8 - 59 - 70 7/8 - 82 5/8 - 94 4/8
 h = 11 6/8 - 17 6/8 - 23 5/8 - 35 3/8
 i = 5 7/8 - 7 7/8 - 11 6/8 - 15 6/8 - 17 6/8 - 23 5/8 - 31 4/8 - 35 3/8
 j = 23 5/8 - 35 3/8 - 39 3/8 - 41 3/8 - 47 2/8 - 50 6/8 - 59 - 70 7/8
 k = 5 7/8 - 11 6/8 - 17 6/8 - 23 5/8 - 35 3/8 - 47 2/8
 l = 23 5/8 - 35 3/8 - 47 2/8
 m = 5 7/8 - 7 7/8 - 11 6/8 - 15 6/8 - 17 6/8 - 23 5/8 - 29 1/2 - 31 4/8 - 35 3/8 - 47 2/8 - 59
 n = 11 6/8 - 17 6/8 - 23 5/8 - 35 3/8 - 47 2/8
 o = 17 6/8 - 23 5/8 - 29 1/2 - 35 3/8 - 47 1/4
 p = 11 6/8 - 17 6/8 - 23 5/8 - 29 1/2 - 35 3/8

MODULARITÀ ARMADI E COLONNE vista frontale e laterale
TALL UNITS & CUPBORDS MODULARITY front view and side view

VERSIONE SENZA GOLA
VERSION WITHOUT GROOVE STRIP

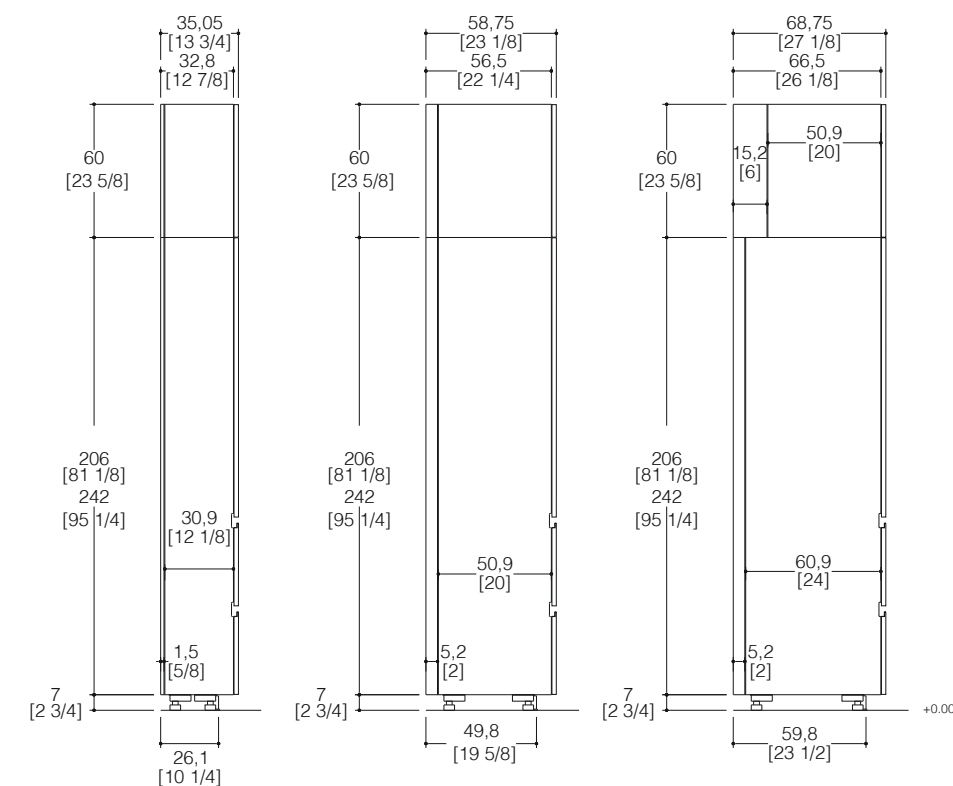
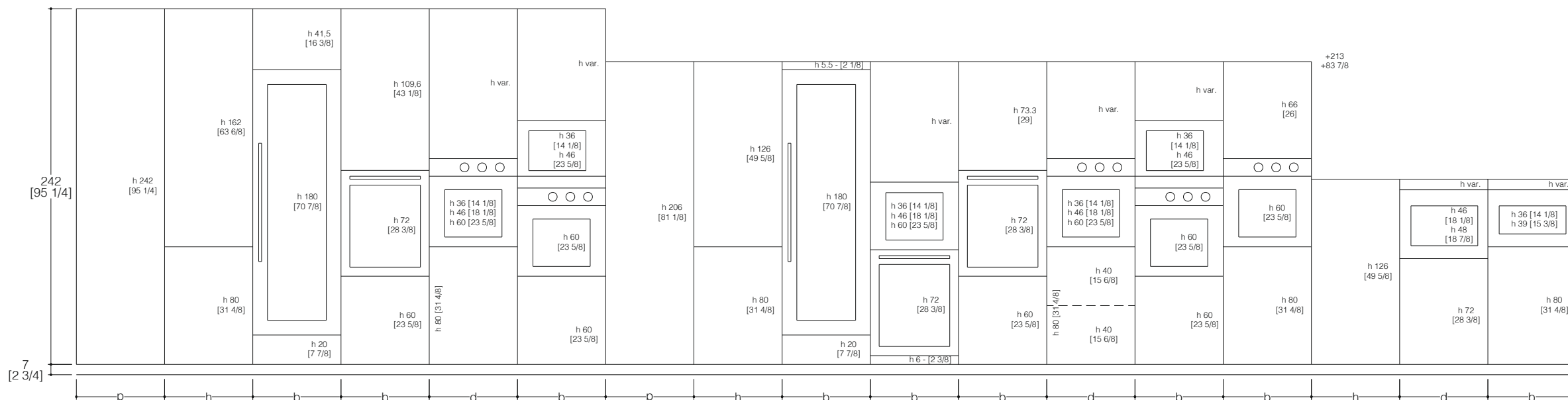

LEGENDA (cm)

- a = 15-20-30-40-45-60-80-90-120cm
- b = 60cm
- c = 30-45-60-75-90-120cm
- d = 60-90cm
- e = 45-60cm
- f = 15-20-30-45-60-90-120cm
- g = 120-150-180-210-240cm
- h = 30-45-60-90cm
- i = 15-20-30-40-45-60-80-90cm
- j = 60-90-100-105.5-120-129-150-180cm
- k = 15-30-45-60-90-120cm
- l = 60-90-120cm
- m = 15-20-30-40-45-60-75-80-90-120-150cm
- n = 30-45-60-90-120cm
- o = 45-60-75-90-120cm
- p = 30-45-60-75-90cm

KEY TO DIMENSION (inches)

- a = 5 7/8 - 7 7/8 - 11 6/8 - 15 6/8 - 17 6/8 - 23 5/8 - 31 4/8 - 35 3/8 - 47 2/8
- b = 23 5/8
- c = 11 6/8 - 17 6/8 - 23 5/8 - 35 3/8 - 47 2/8
- d = 23 5/8 - 35 3/8
- e = 17 6/8 - 23 5/8
- f = 5 7/8 - 7 7/8 - 11 6/8 - 17 6/8 - 23 5/8 - 35 3/8 - 47 2/8
- g = 47 2/8 - 59 - 70 7/8 - 82 5/8 - 94 4/8
- h = 11 6/8 - 17 6/8 - 23 5/8 - 35 3/8
- i = 5 7/8 - 7 7/8 - 11 6/8 - 15 6/8 - 17 6/8 - 23 5/8 - 31 4/8 - 35 3/8
- j = 23 5/8 - 35 3/8 - 39 3/8 - 41 3/8 - 47 2/8 - 50 6/8 - 59 - 70 7/8
- k = 5 7/8 - 11 6/8 - 17 6/8 - 23 5/8 - 35 3/8 - 47 2/8
- l = 23 5/8 - 35 3/8 - 47 2/8
- m = 5 7/8 - 7 7/8 - 11 6/8 - 15 6/8 - 17 6/8 - 23 5/8 - 29 1/2 - 31 4/8 - 35 3/8 - 47 2/8 - 59
- n = 11 6/8 - 17 6/8 - 23 5/8 - 35 3/8 - 47 2/8
- o = 17 6/8 - 23 5/8 - 29 1/2 - 35 3/8 - 47 1/4
- p = 11 6/8 - 17 6/8 - 23 5/8 - 29 1/2 - 35 3/8

MODULARITÀ BASI E COLONNE per elettrodomestici con standard americano, vista frontale e laterale
BASE CABINETS & TALL UNITS MODULARITY for US standard appliances, front view and side view

61 - 68,6 - 76,2 - 91,4 61 - 68,6 - 76,2 - 91,4 61 - 68,6 - 76,2 - 91,4
[24] - [27] - [30] - [36] [24] - [27] - [30] - [36] [24] - [27] - [30] - [36]

VERSIONE CON GOLA
VERSION WITH GROOVE STRIP

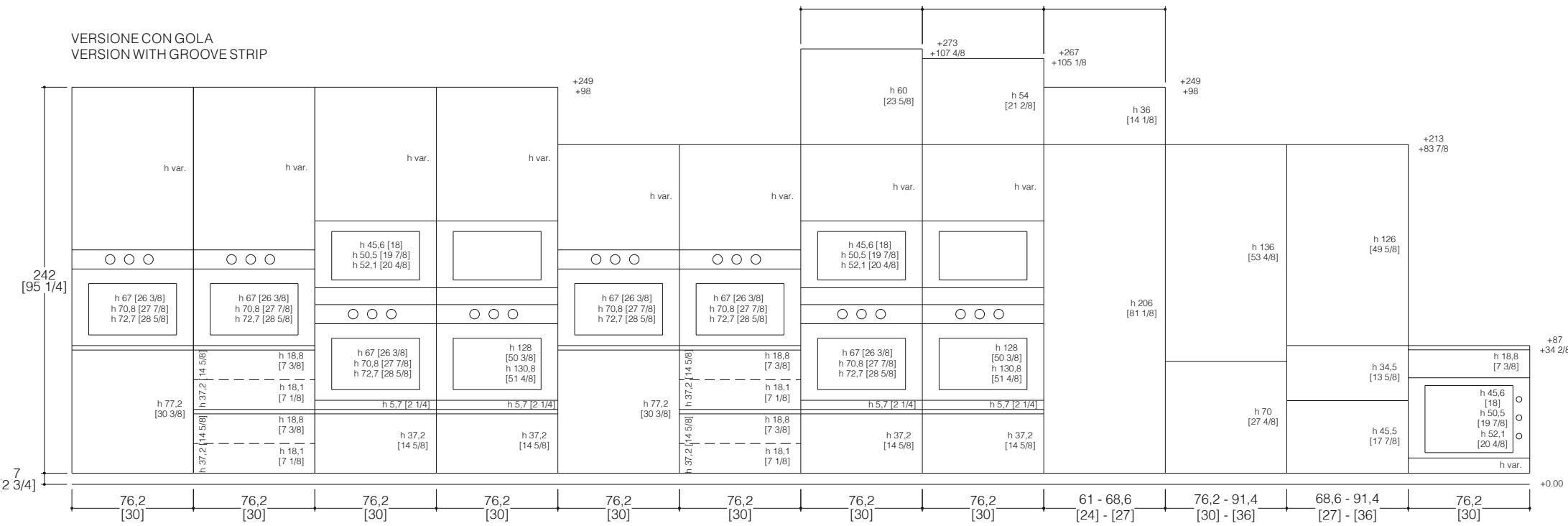

LEGENDA (cm)

- a = 15-20-30-40-45-60-80-90-120cm
- b = 60cm
- c = 30-45-60-75-90-120cm
- d = 60-90cm
- e = 45-60cm
- f = 15-20-30-45-60-90-120cm
- g = 120-150-180-210-240cm
- h = 30-45-60-90cm
- i = 15-20-30-40-45-60-80-90cm
- j = 60-90-100-105.5-120-129-150-180cm
- k = 15-30-45-60-90-120cm
- l = 60-90-120cm
- m = 15-20-30-40-45-60-75-80-90-120-150cm
- n = 30-45-60-90-120cm
- o = 45-60-75-90-120cm
- p = 30-45-60-75-90cm

KEY TO DIMENSION (inches)

- a = 5 7/8 - 7 7/8 - 11 6/8 - 15 6/8 - 17 6/8 - 23 5/8 - 31 4/8 - 35 3/8 - 47 2/8
- b = 23 5/8
- c = 11 6/8 - 17 6/8 - 23 5/8 - 35 3/8 - 47 2/8
- d = 23 5/8 - 35 3/8
- e = 17 6/8 - 23 5/8
- f = 5 7/8 - 7 7/8 - 11 6/8 - 17 6/8 - 23 5/8 - 35 3/8 - 47 2/8
- g = 47 2/8 - 59 - 70 7/8 - 82 5/8 - 94 4/8
- h = 11 6/8 - 17 6/8 - 23 5/8 - 35 3/8
- i = 5 7/8 - 7 7/8 - 11 6/8 - 15 6/8 - 17 6/8 - 23 5/8 - 31 4/8 - 35 3/8
- j = 23 5/8 - 35 3/8 - 39 3/8 - 41 3/8 - 47 2/8 - 50 6/8 - 59 - 70 7/8
- k = 5 7/8 - 11 6/8 - 17 6/8 - 23 5/8 - 35 3/8 - 47 2/8
- l = 23 5/8 - 35 3/8 - 47 2/8
- m = 5 7/8 - 7 7/8 - 11 6/8 - 15 6/8 - 17 6/8 - 23 5/8 - 29 1/2 - 31 4/8 - 35 3/8 - 47 2/8 - 59
- n = 11 6/8 - 17 6/8 - 23 5/8 - 35 3/8 - 47 2/8
- o = 17 6/8 - 23 5/8 - 29 1/2 - 35 3/8 - 47 1/4
- p = 11 6/8 - 17 6/8 - 23 5/8 - 29 1/2 - 35 3/8

VERSIONE SENZA GOLA
VERSION WITHOUT GROOVE STRIP

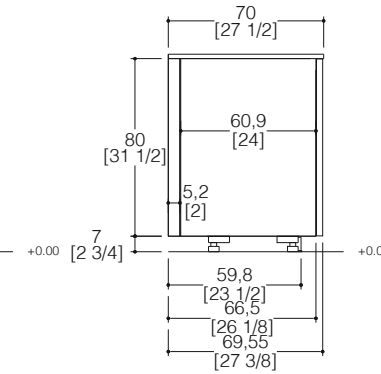
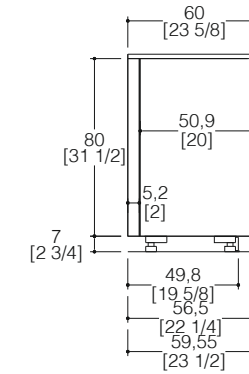
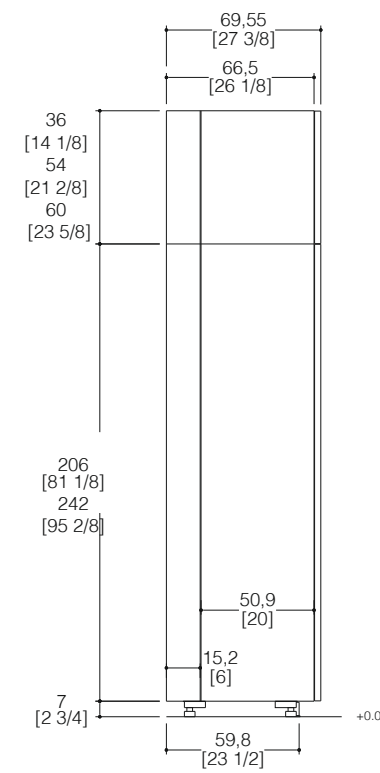
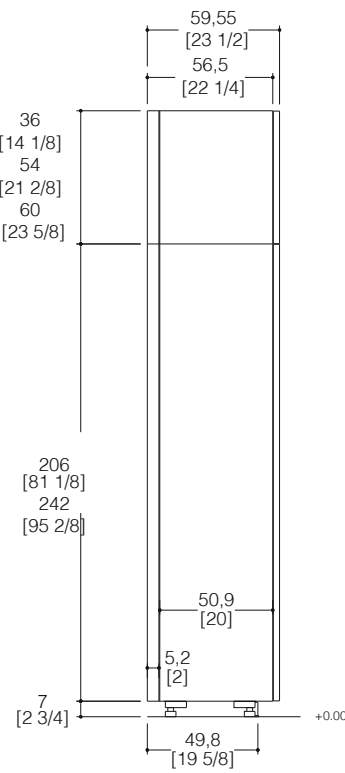
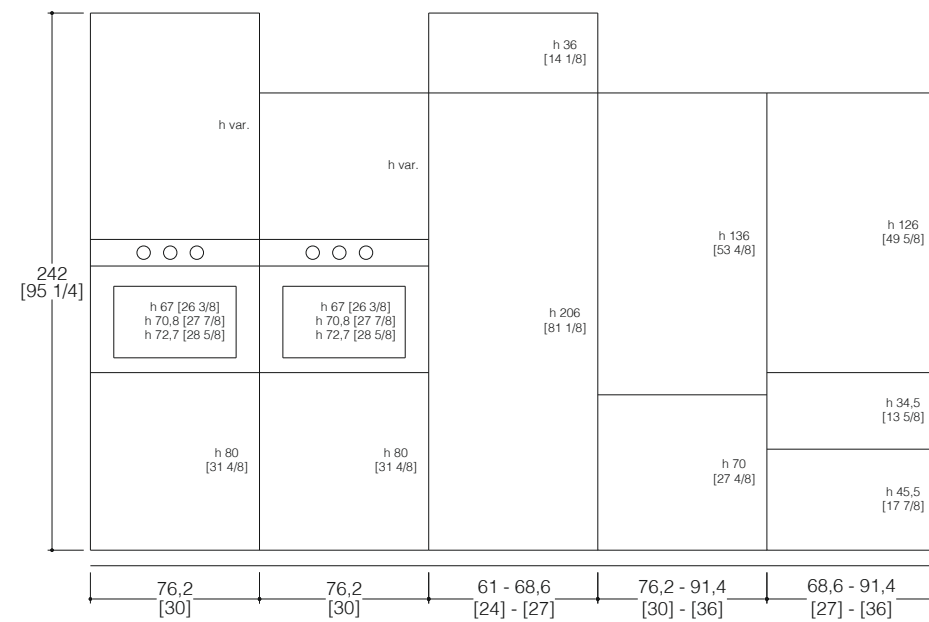

MODULARITÀ PENSILI vista frontale e laterale
WALL CABINETS MODULARITY front view and side view

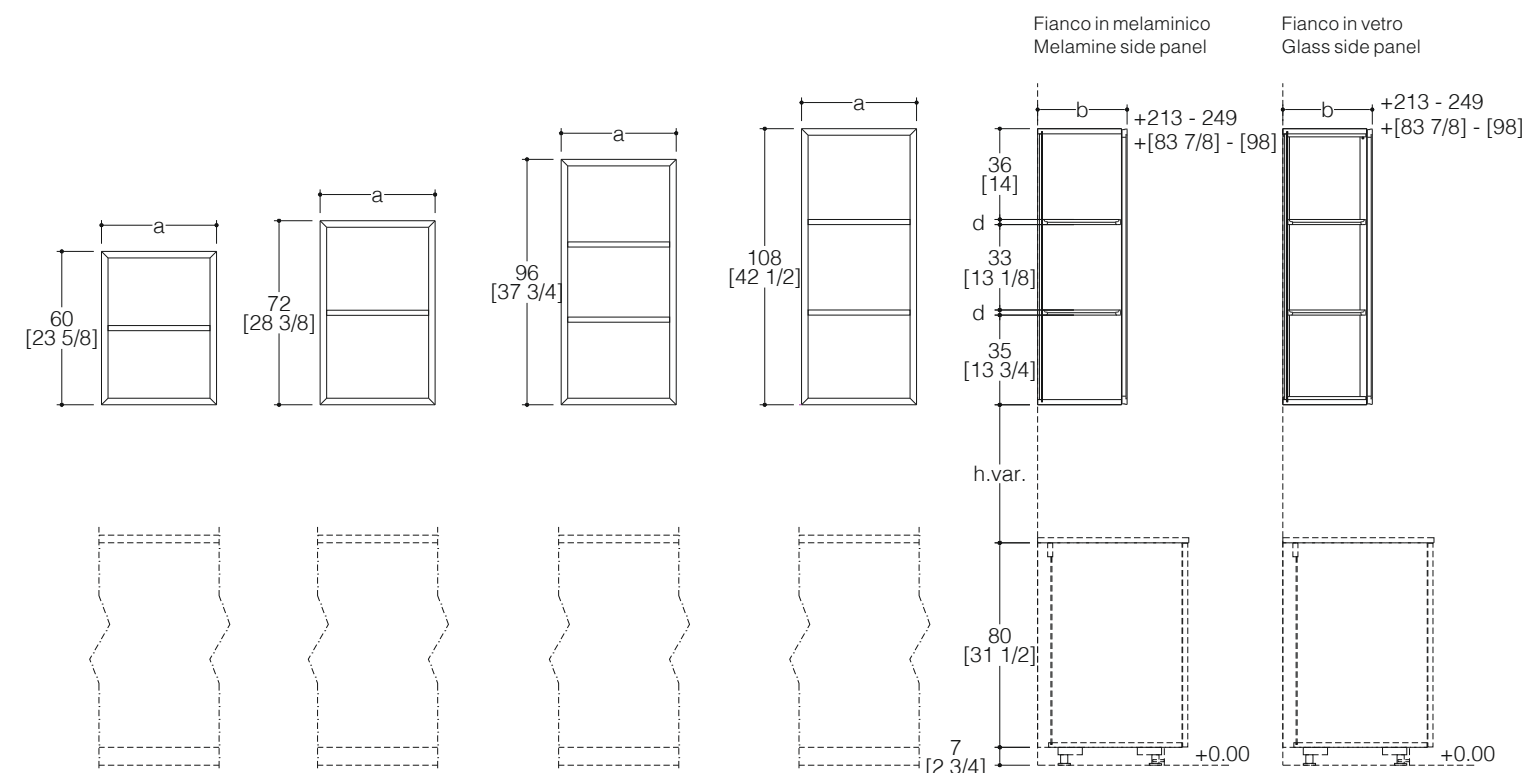

Sistema basi pensili vetrina View

Caratteristiche
Il sistema è disponibile sia in versione sospesa che a pavimento, dotato di anta in telaio alluminio e vetro, con apertura push pull.

Fattibilità
È possibile personalizzare la struttura nelle finiture melamminiche del programma Sign. È possibile personalizzare il fianco in telaio alluminio e vetro come l'anta, nelle finiture del programma Sign. È possibile attrezzare il ripiano melamminico o il ripiano alluminio e vetro.

Vincoli
Riduzioni/aumenti dimensionali in altezza, larghezza e profondità, non sono ammessi in presenza di fianco in vetro. Non è possibile affiancare il fianco in vetro ad un qualsiasi mobile o a muro, è necessario lasciare un vuoto di almeno 5 cm [2"].

Sistema armadi vetrina View

Caratteristiche
Il sistema è disponibile sia in versione sospesa che a pavimento, dotato di anta in telaio alluminio e vetro con apertura push pull.

Fattibilità
È possibile personalizzare la struttura nelle finiture melamminiche del programma Sign. È possibile personalizzare il fianco in telaio alluminio e vetro come l'anta, nelle finiture del programma Sign. È possibile attrezzare il ripiano melamminico, il ripiano alluminio e vetro, il ripiano porta bottiglie o il cassetto; il fondo del cassetto è rivestito in ecopelle.

Vincoli
Riduzioni/aumenti dimensionali in altezza, larghezza e profondità, non sono ammessi in presenza di fianco in vetro. Non è possibile affiancare il fianco in vetro ad un qualsiasi mobile o a muro, è necessario lasciare un vuoto di almeno 5 cm [2"].

View glass-fronted base and wall unit system

Characteristics
The system is available in both wall-mounted and floor version, with glass doors with aluminium frame and push-pull opening.

Feasibility
The structure can be customised in the melamine finishes of the Sign programme. The side panel can be customised in glass with aluminium frame to match the door, in the Sign programme finishes. Units can be fitted with melamine or aluminium and glass shelves.

Constraints
No reductions/increases in height, width or depth are permitted on units with glass side panel. Glass side panels cannot be placed directly next to any item of furniture or a wall: a gap of at least 5 cm must be left [2"].

View glass-fronted cupboard system

Characteristics
The system is available in both wall-mounted and floor version, with glass doors with aluminium frame and push-pull opening.

Feasibility
The structure can be customised in the melamine finishes of the Sign programme. The side panel can be customised in glass with aluminium frame to match the door, in the Sign programme finishes. Cupboards can be fitted with melamine or aluminium and glass shelves, bottle rack shelves or drawers; drawer bottoms are lined with eco-leather.

Constraints
No reductions/increases in height, width or depth are permitted on units with glass side panel. Glass side panels cannot be placed directly next to any item of furniture or a wall: a gap of at least 5 cm must be left [2"].

MODULARITÀ BASE E PENSILE h.120 vista frontale e laterale
h. 47 1/4 BASE CABINETS and WALL CABINETS, MODULARITY front view and side view

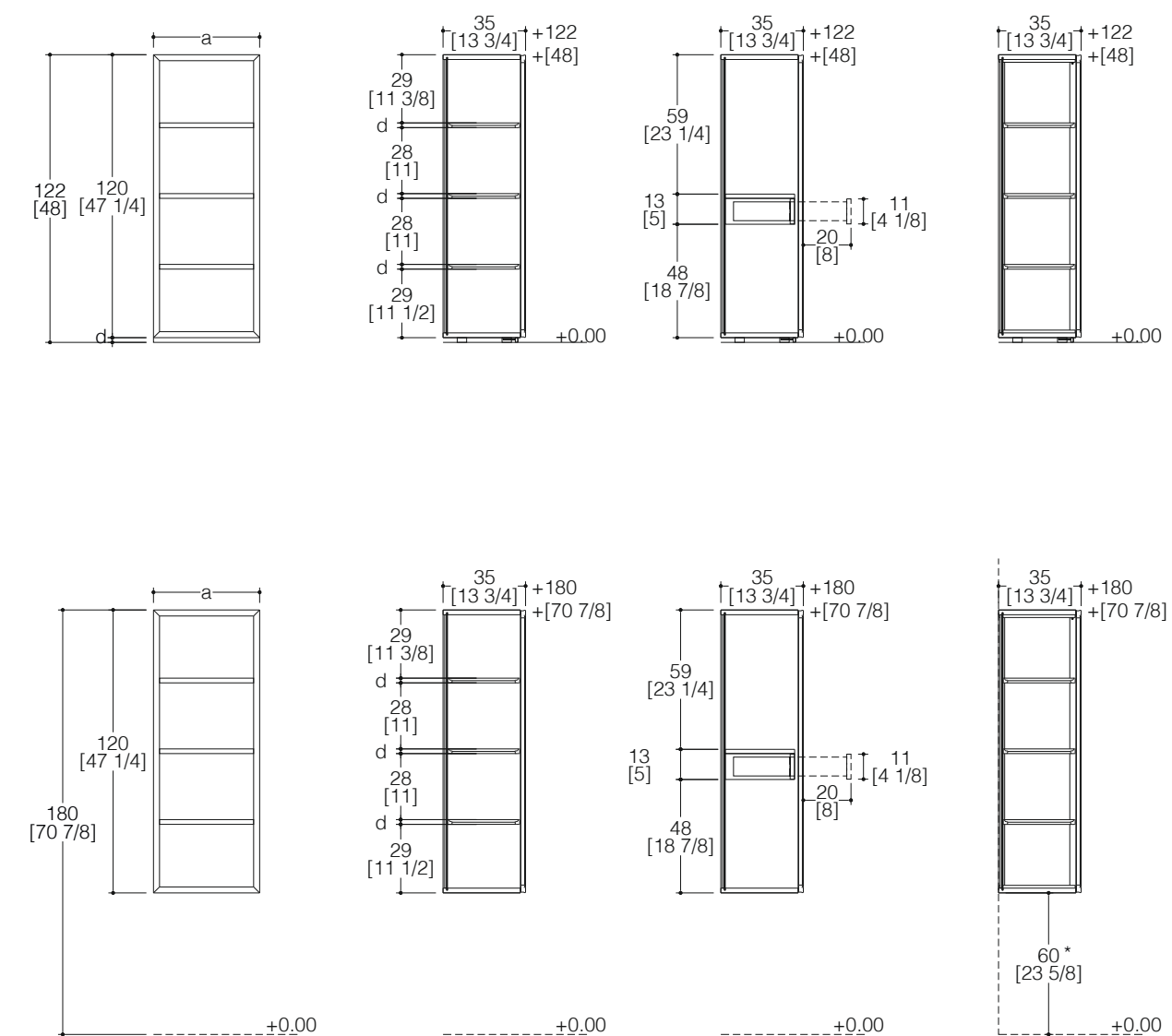

LEGENDA (cm)	KEY TO DIMENSION (inches)
a = 45 - 60	a = 17 3/4 - 23 5/8
b = 35 - 45	b = 13 3/4 - 17 3/4
c = 45 - 60 - 70	c = 17 3/4 - 23 5/8 - 27 1/2
d = 2	d = 3/4
e = 3	e = 1 1/8
f = 26,5 - 41,5 - 51,5	f = 10 3/8 - 16 3/8 - 20 1/4

* altezza consigliata
recommended height

MODULARITÀ COLONNE vista frontale e laterale
TALL UNITS MODULARITY front view and side view

COLONNE PER ARMADI STANDARD
TALL UNITS FOR STANDARD CABINETS

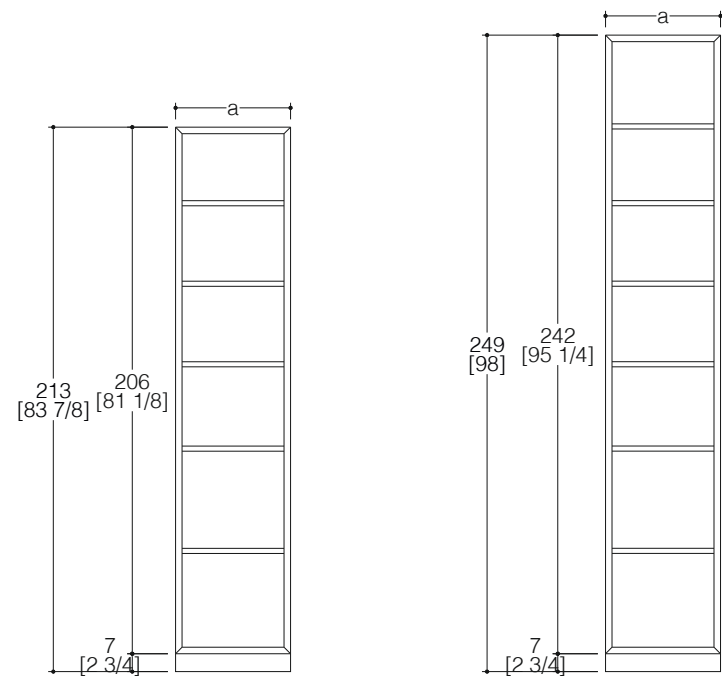

Configurazione con ripiani o ripiani Mix
Configuration with shelves or Mix shelves

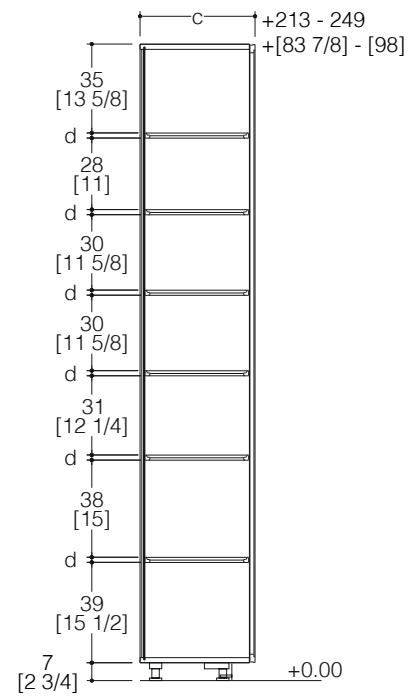

Configurazione con ripiani porta bottiglie
Configuration with bottle shelves

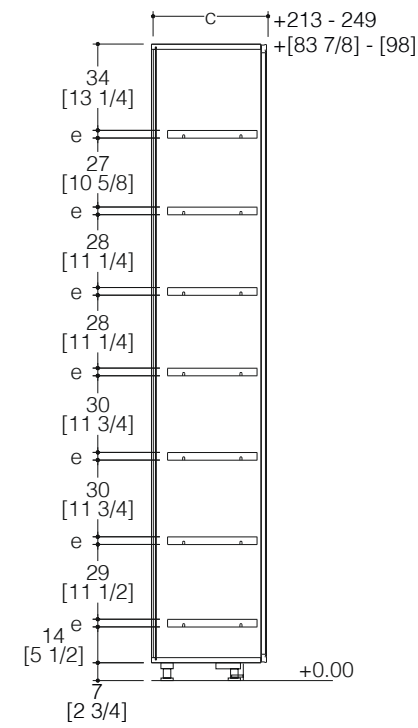

Configurazione con cassetto
Configuration with drawer

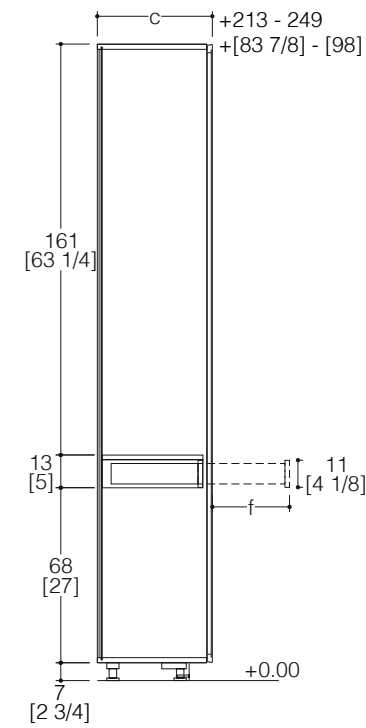

Configurazione con fianco in vetro e ripiani Mix
Configuration with glass side panel and Mix shelves

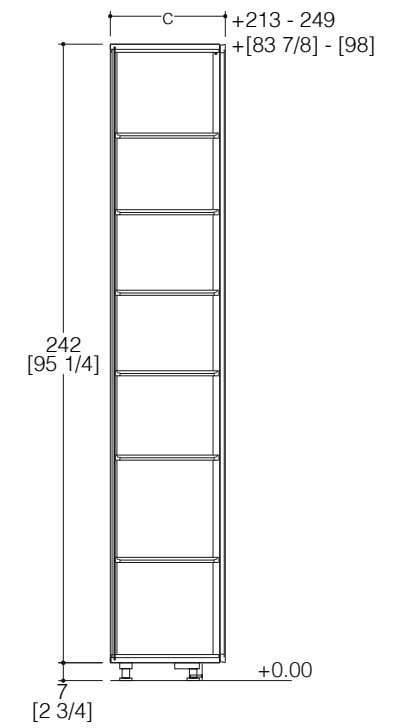

COLONNE PER ARMADI IN SPACE
TALL UNITS FOR IN SPACE CABINETS

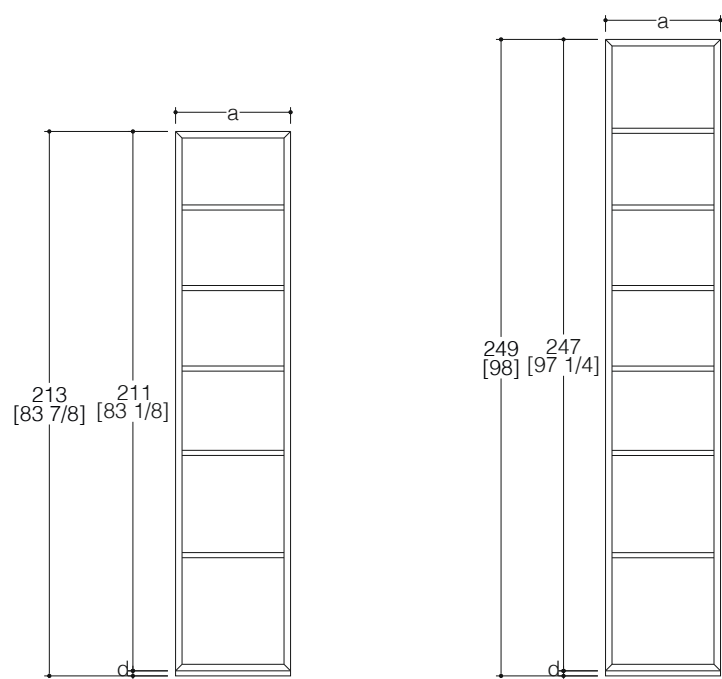

Configurazione con ripiani o ripiani Mix
Configuration with shelves or Mix shelves

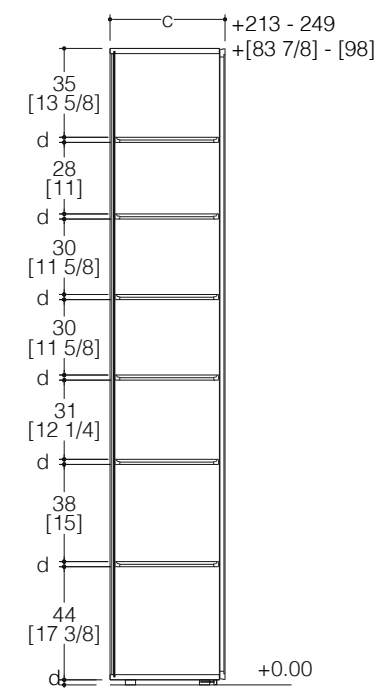

Configurazione con ripiani porta bottiglie
Configuration with bottle shelves

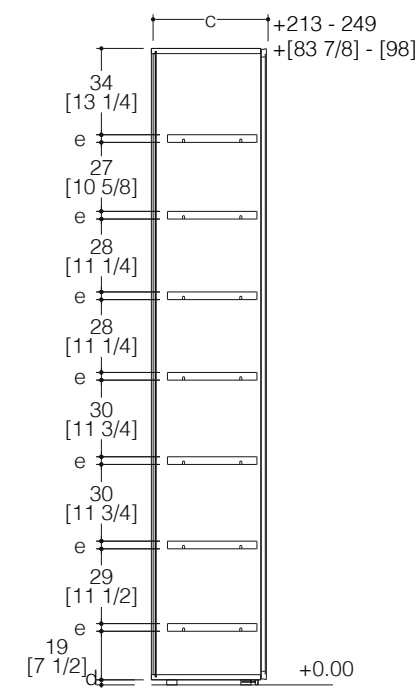

Configurazione con cassetto
Configuration with drawer

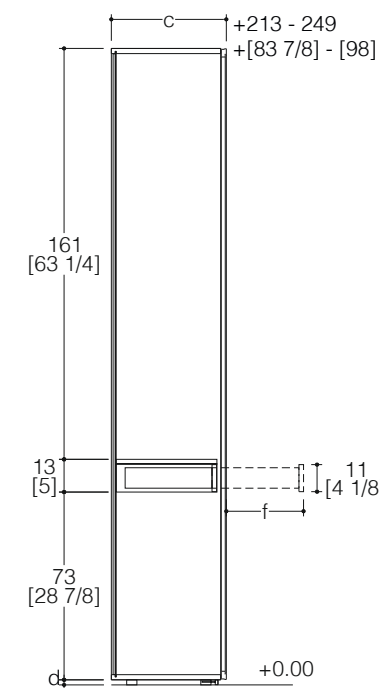

Configurazione con fianco in vetro e ripiani Mix
Configuration with glass side panel and Mix shelves

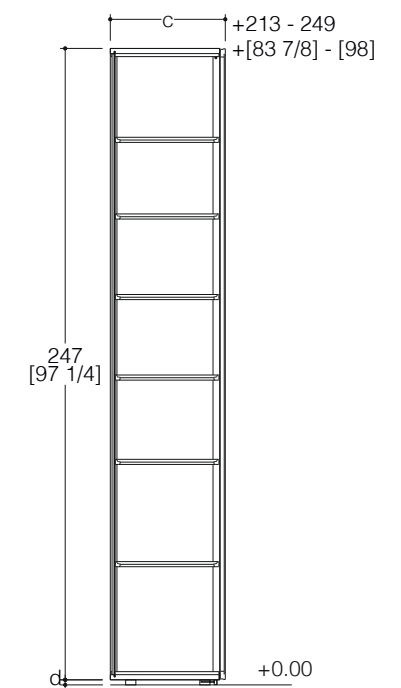

MODULARITÀ PENSILE vista frontale e laterale
WALL CABINET MODULARITY front view and side view

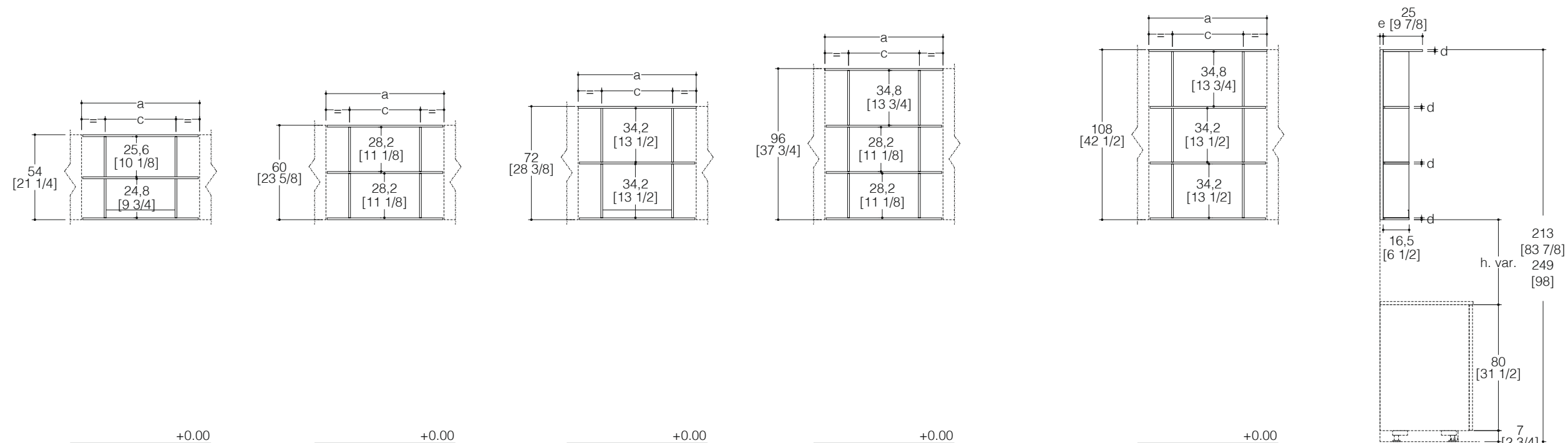

LEGENDA (cm)
a = 60 - 75* - 90* - 120
b = 54 - 60 - 96 - 108
c = 30 - 45 - 60
d = 1,2
e = 2
* stesso vano (c = 45)

KEY TO DIMENSION (inches)
a = 23 5/8 - 29 1/2* - 35 3/8* - 47 1/4
b = 21 1/4 - 23 5/8 - 37 3/4 - 42 1/2
c = 11 3/4 - 17 3/4 - 23 5/8
d = 1/2
e = 3/4
* same compartment (c = 17 3/4)

MODULARITÀ SOTTOPENSILE vista frontale e laterale
WALL UNDER CABINET MODULARITY front view and side view

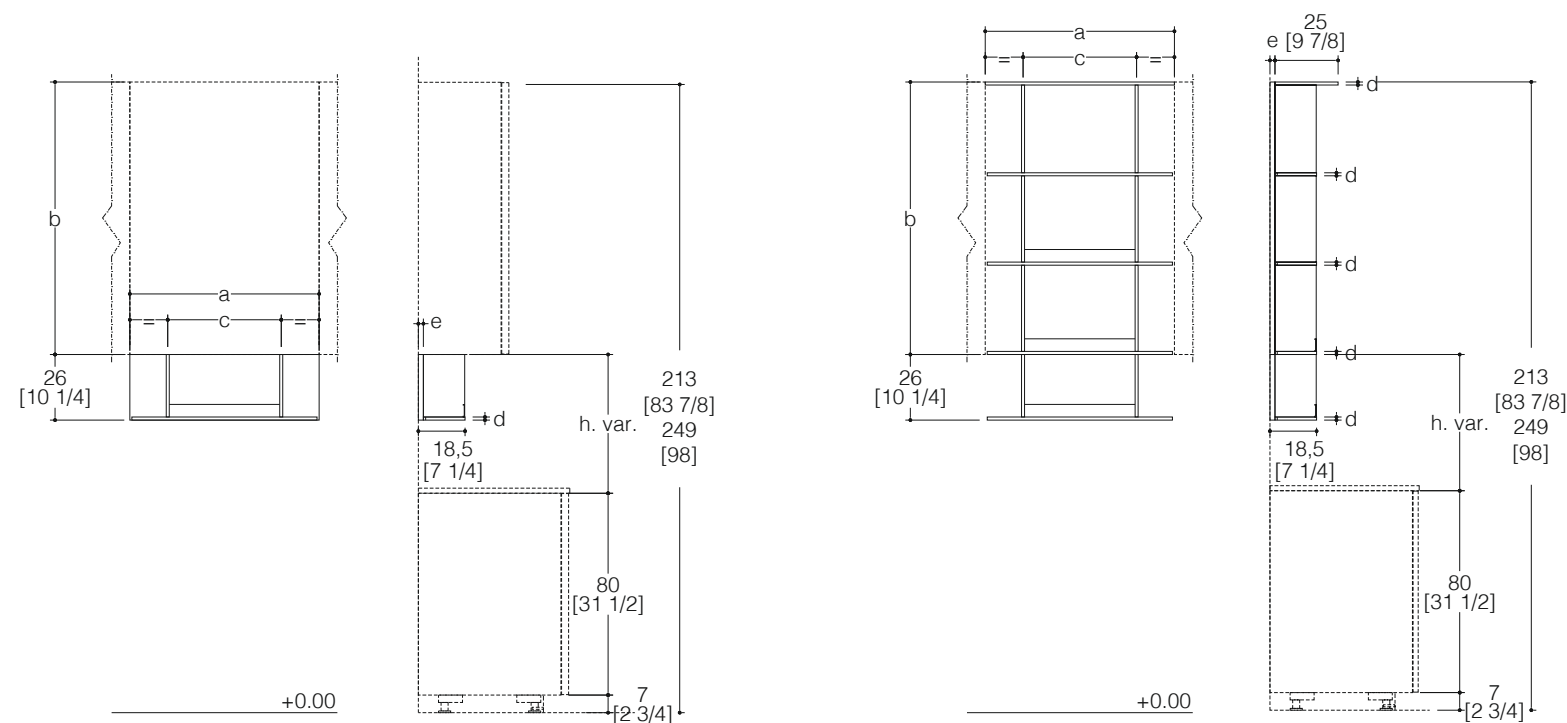

Caratteristiche

Gli scaffali Stay sono un sistema modulare di mensole con divisori, agganciabili su pannelli boiserie. I materiali degli scaffali e dei pannelli, possono essere Melaminico, Fenix, Laccato e Impiallacciato e possono essere anche mixati tra loro. All'interno del vano, che può essere caratterizzato da un profilo di finitura in alluminio, possono essere inseriti accessori dedicati.

Fattibilità

I pannelli boiserie con relativi scaffali possono essere installati fino a terra, sospesi, tra basi e pensili o affiancati indistintamente a basi, pensili e colonne o semplicemente tra loro. In ogni mensola spessore 1.2 cm [1/2"] è possibile attrezzare l'illuminazione led, attivabile tramite interruttore remoto. È possibile ridurre in altezza e in larghezza i pannelli boiserie e i relativi scaffaletti. Per le finiture degli accessori Legno fare riferimento al listino Sign.

Vincoli

Non è possibile effettuare composizioni ad angolo.

Characteristics

Stay shelves are a modular shelving system with dividers which can be mounted on boiserie panels. The shelves and panels may be in Melamine, Fenix, Lacquered or Veneered finishes, or any combination of these. Specific accessories can be mounted in the interior, which can be fitted with an aluminium trim.

Feasibility

The boiserie panel with shelves may be installed right down to the ground, wall-mounted, as a midway system, next to base, wall and tall units or simply between them. Each shelf 1.2 cm [1/2"] thick can be fitted with Led lighting, controlled via a remote switch. The height and width of the boiserie panels and the relative shelves can be reduced. Refer to the Sign price list for the finishes of Wood accessories.

Constraints

It is not possible to create corner compositions.

MODULARITÀ BOISERIE vista frontale e laterale
BOISERIE MODULARITY front view and side view

TIPO 1

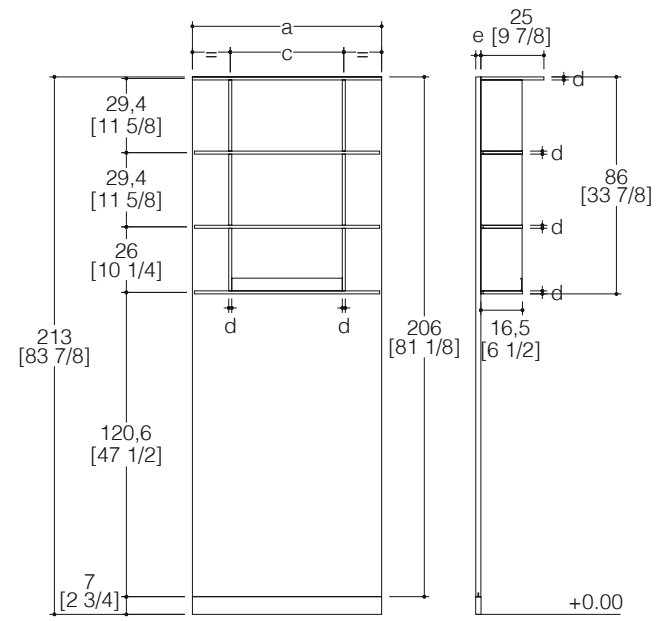

TIPO 1A

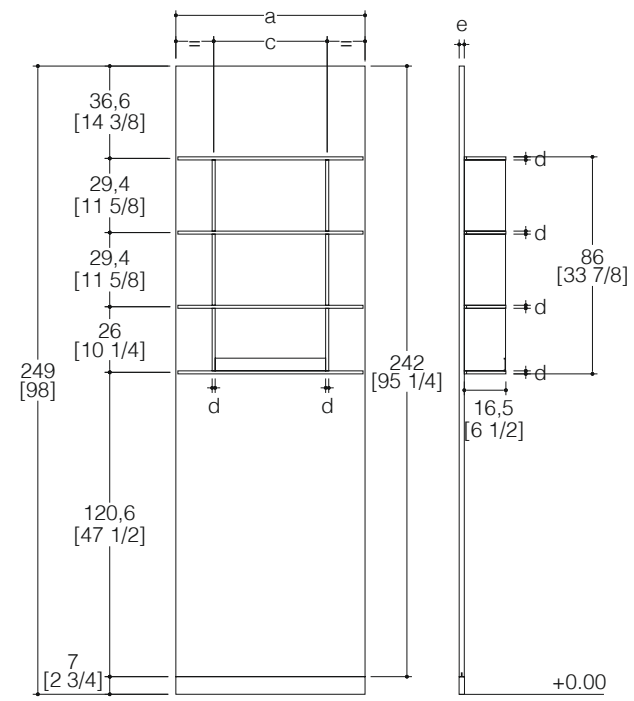

TIPO 2

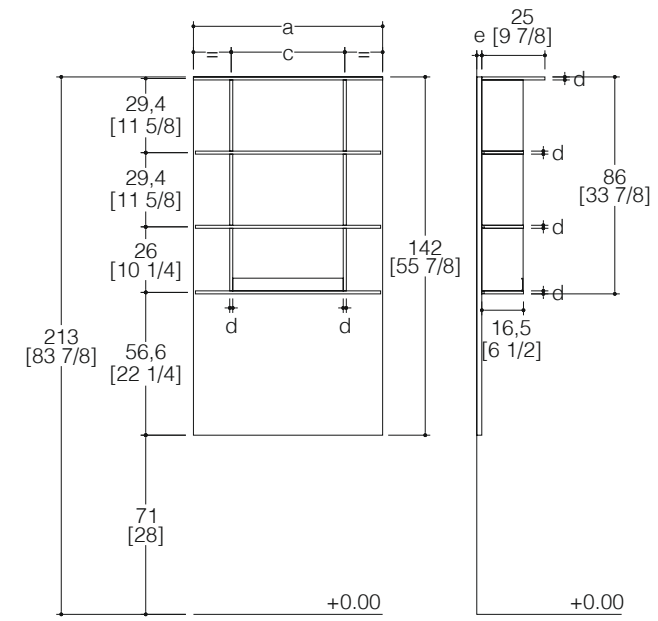

TIPO 2A

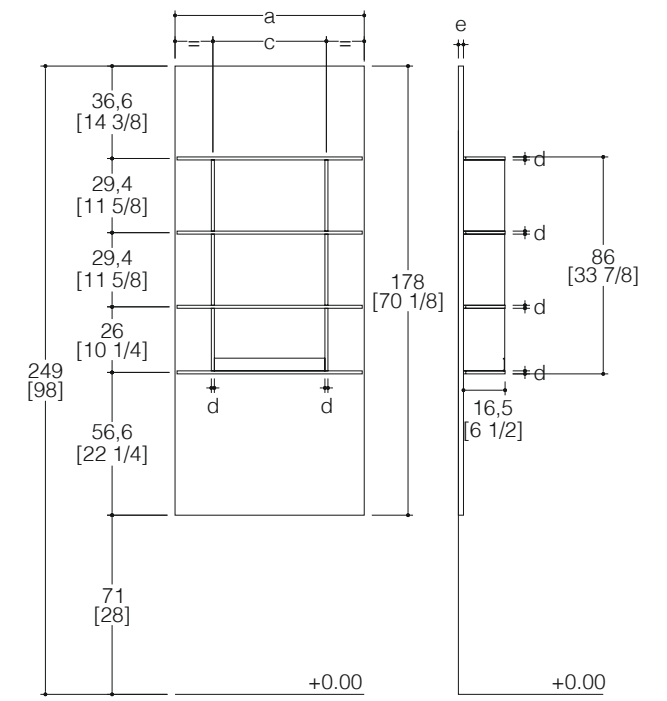

TIPO 3

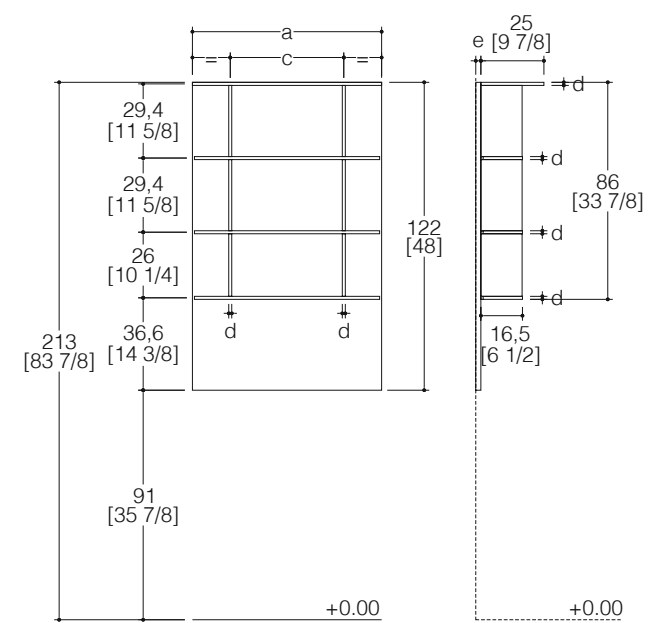

TIPO 3A

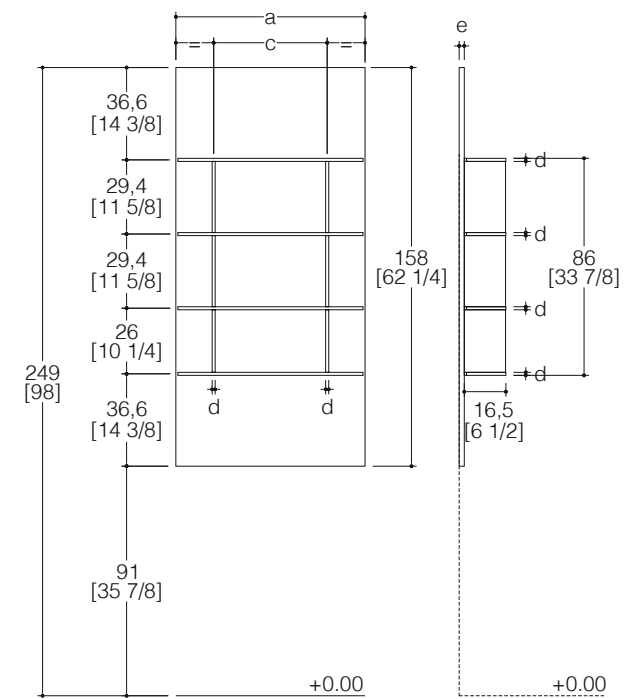

TIPO 4

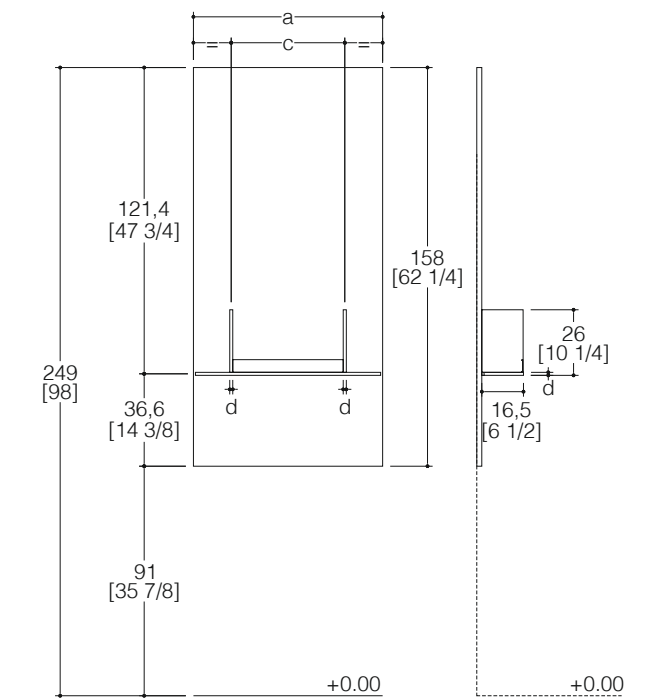

TIPO 5

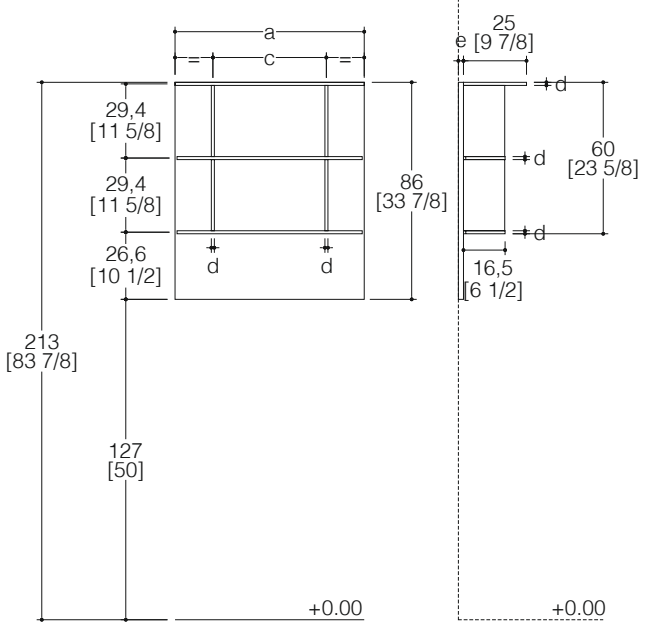

MODULARITÀ BOISERIE vista frontale e laterale
BOISERIE MODULARITY front view and side view

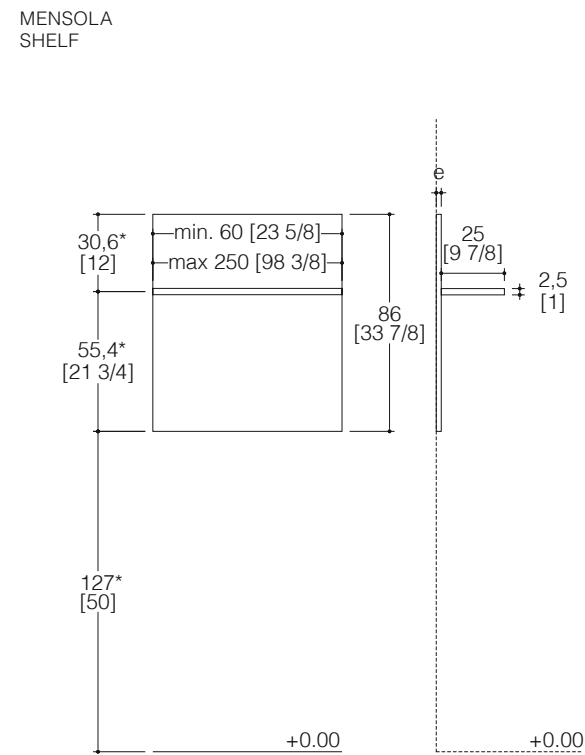
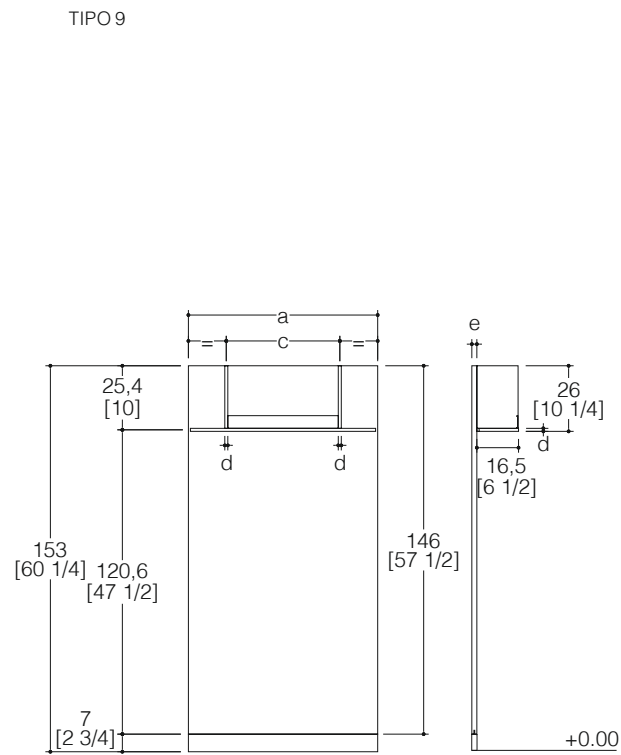
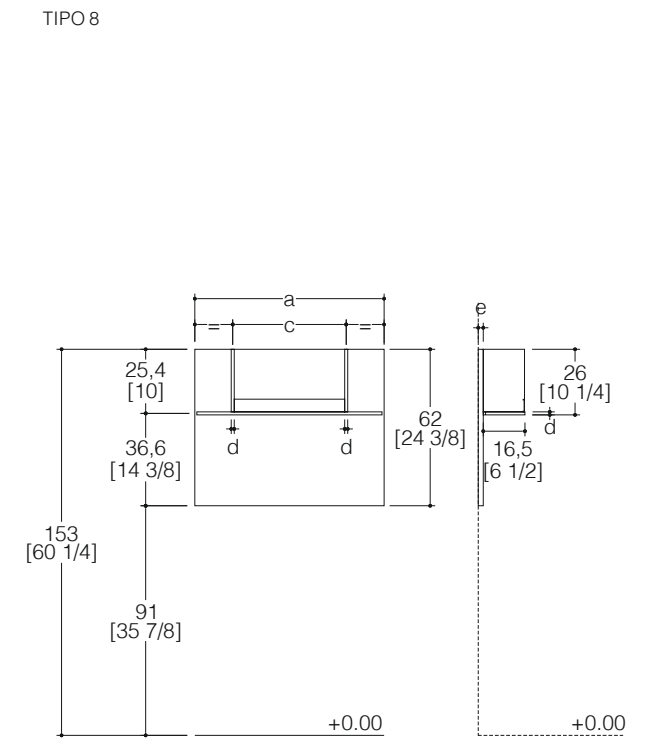
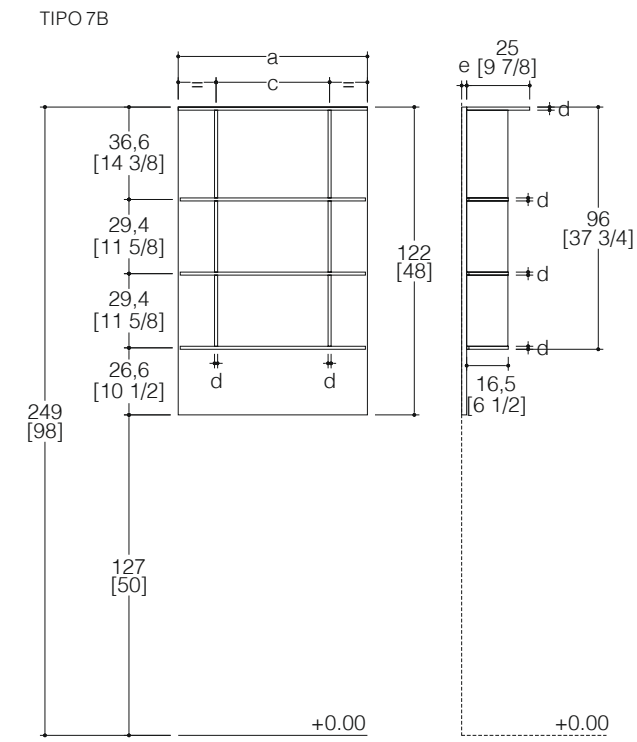
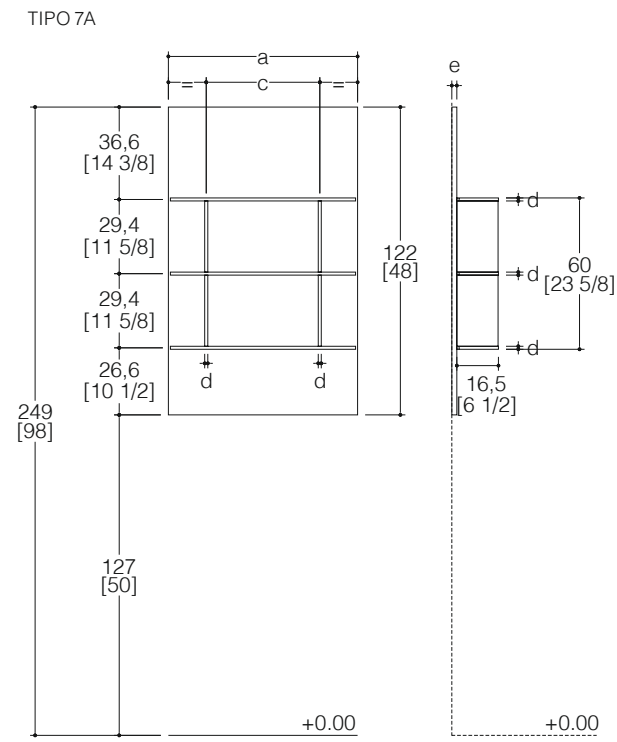
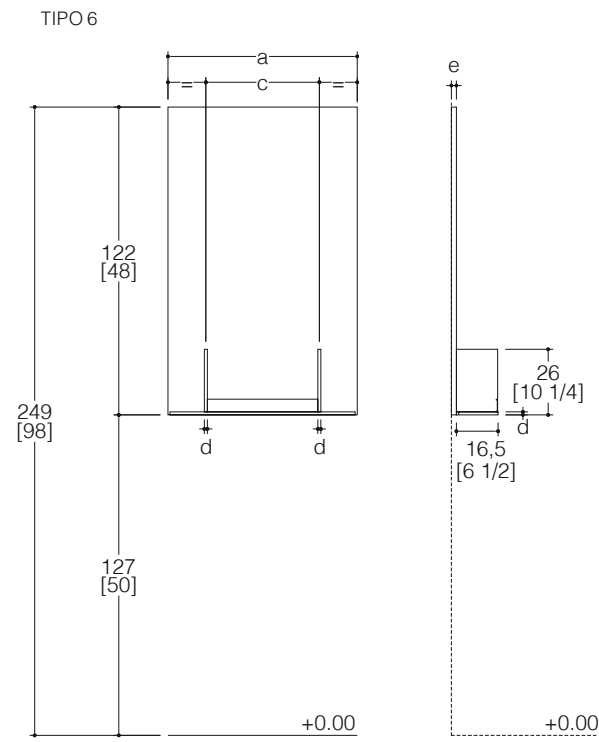

* misura indicativa
indicative measure

ACCESSORI
ACCESSORIES

PER c1
FOR c1

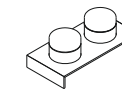

PORTA BARATTOLI PICCOLO 28,6 x 14,2 cm
SMALL JAR HOLDER 11 1/4 x 5 5/8 inc.

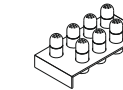

PORTASPEZIE 28,6 x 14,2 cm
SPICE HOLDER 11 1/4 x 5 5/8 inc.

PER c2
FOR c2

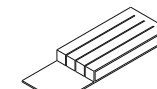

PORTA COLTELLI PICCOLO 43,6 x 14,2 cm
SMALL KNIFE HOLDER 17 1/8 x 5 5/8 inc.



PORTA PELLICOLE 35,6 x 14,2 cm
FILM HOLDER 14 x 5 5/8 inc.

PER c3
FOR c3



PORTA COLTELLI GRANDE 47,3 x 14,2 cm
LARGE KNIFE HOLDER 18 5/8 x 5 5/8 inc.

VANO TIPO = c

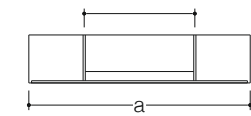

c1 = 28,8 [11 3/8]
c2 = 43,8 [17 1/4]
c3 = 58,8 [23 1/8]

LEGENDA (cm)
a = 60 - 75* - 90* - 120
b = 54 - 60 - 96 - 108
c = 30 - 45 - 60
d = 1,2
e = 2
* stesso vano (c = 45)

KEY TO DIMENSION (inches)
a = 23 5/8 - 29 1/2* - 35 3/8* - 47 1/4
b = 21 1/4 - 23 5/8 - 37 3/4 - 42 1/2
c = 11 3/4 - 17 3/4 - 23 5/8
d = 1/2
e = 3/4
* same compartment (c = 17 3/4)

MODULARITÀ vista frontale, VERSIONE SENZA GOLA
MODULARITY front view

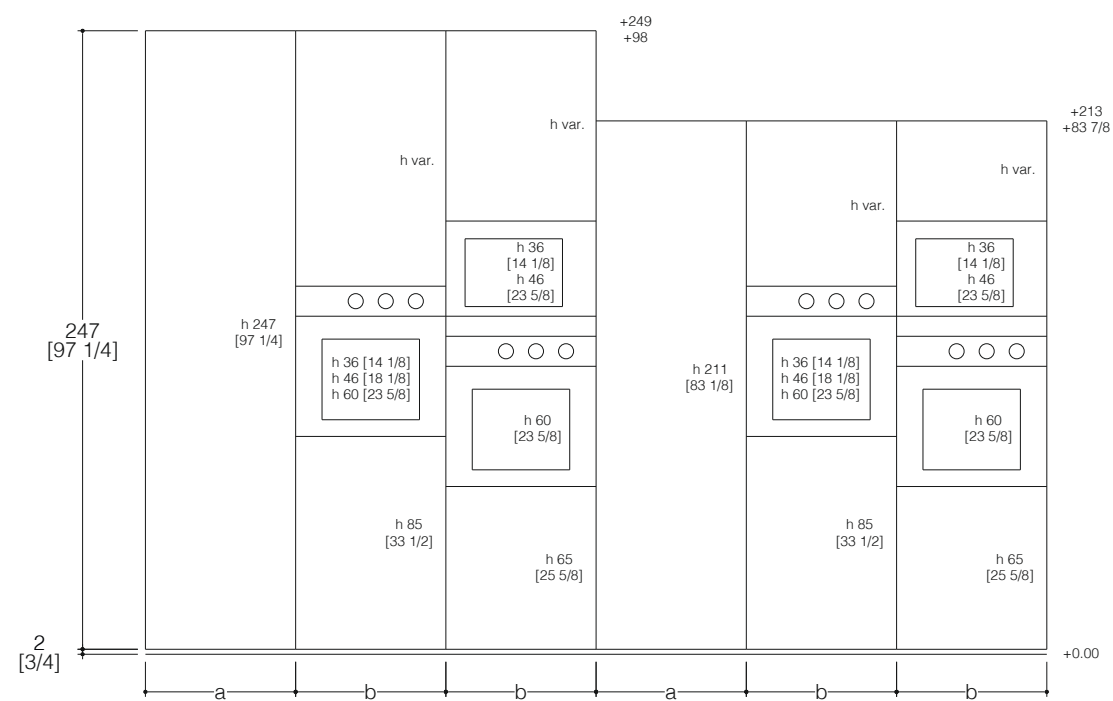

LEGENDA (cm)
a = 30-45-60-61-75cm
b = 60cm

KEY TO DIMENSION (inches)
h = $11\ 6/8$ - $17\ 3/4$ - $23\ 5/8$ - 24 - $29\ 1/2$
b = $23\ 5/8$

vista laterale
side view

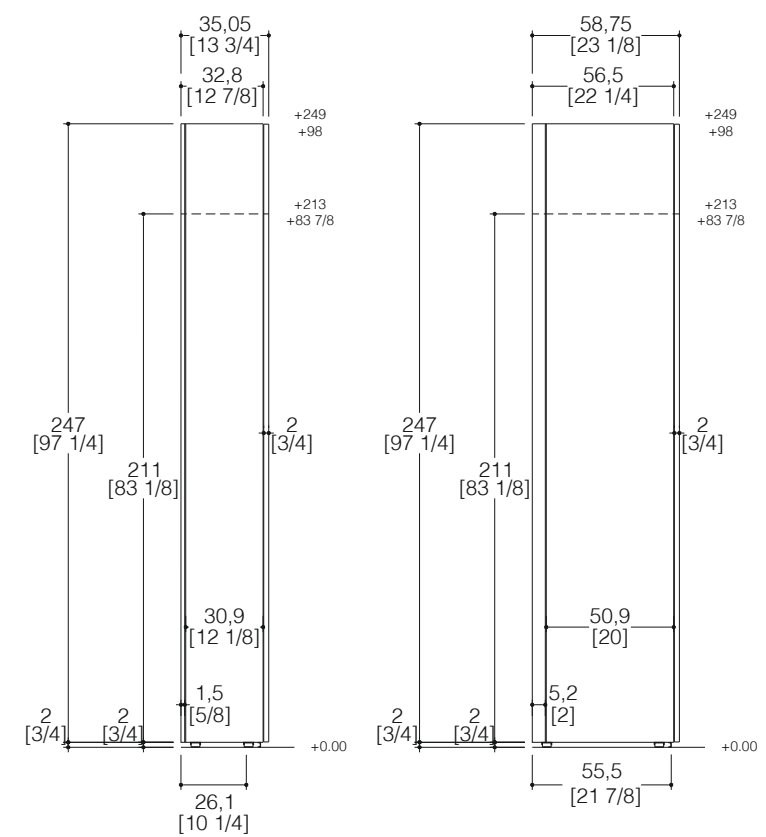

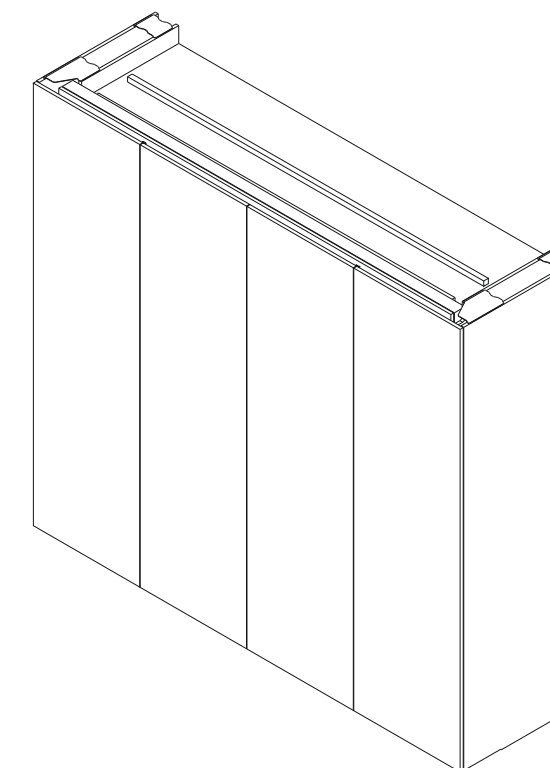
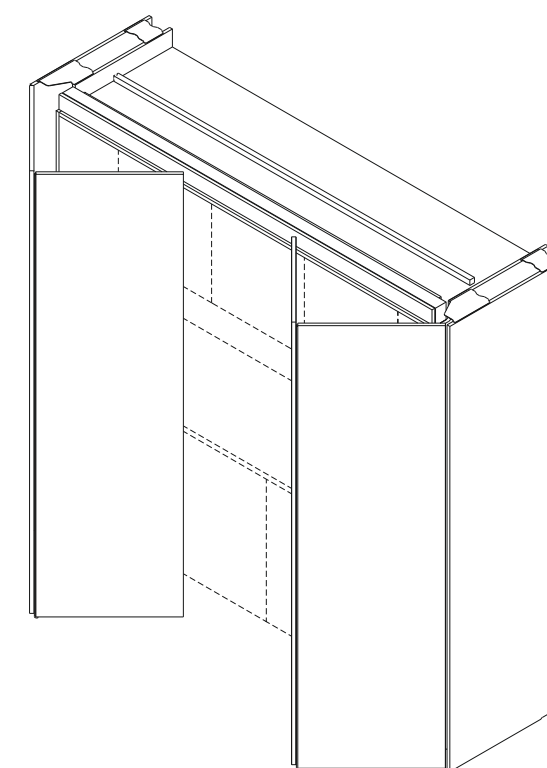
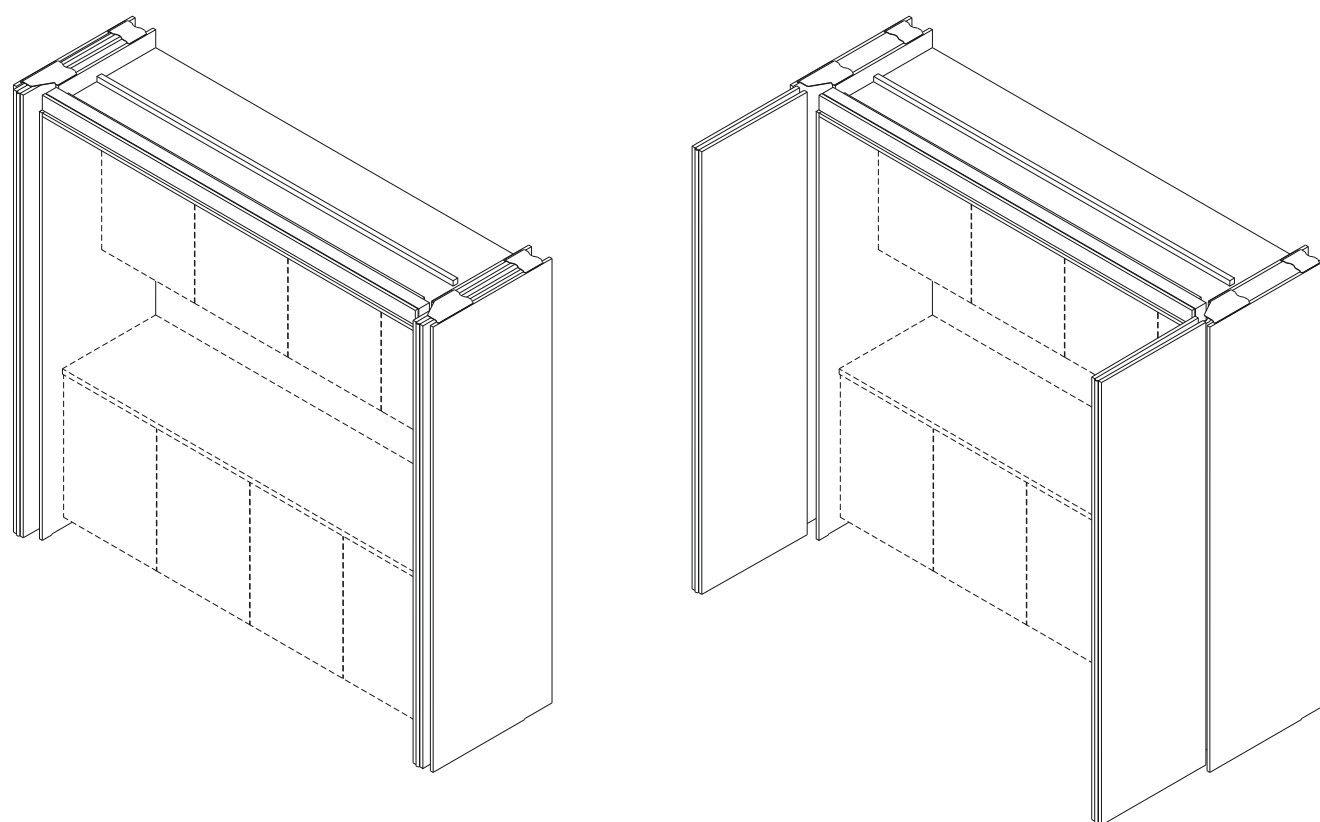
MODULARITÀ vista assonometrica
MODULARITY isometric view**Caratteristiche**

Sistema di ante scorrevoli rientranti per applicazione a due ante doppie e vano tecnico integrato in due singoli corpi mobile, ognuno dei quali sviluppa un ingombro di 15 cm [5 7/8"], per un ingombro totale pari a 30 cm [11 3/4"].

Fattibilità

È possibile affiancare più sistemi tra loro o qualsiasi tipologia di base, pensile, colonna o copri fianco fino a terra, direttamente al lato esterno dei corpi mobile. Il fianco esterno del corpo mobile può essere lasciato a vista.

Vincoli

Non è possibile eseguire fuori misura in altezza, larghezza, profondità. Il sistema non è adatto ad essere utilizzato come parete divisoria. Non è possibile sovrapporre sopra armadi. Non è possibile impiegare copri fianchi che non appoggino a terra. Per motivi di stabilità occorre montare, per tutto lo sviluppo interno, dei mobili (basi, pensili, colonne...). Non è possibile inserire in adiacenza ai fianchi interni, alcune tipologie di mobili o elettrodomestici aventi apertura nello stesso verso dei fianchi a cui sono adiacenti (es. mobili con maniglie sporgenti, con cerniere a protrusione zero, con frigo, con forni, cantine vino...). Sul lato superiore del sistema deve esserci uno spazio minimo di almeno 2 cm [3/4"] . Sul lato anteriore del sistema deve esserci uno spazio minimo pari alla larghezza del frontale + 30 cm [11 3/4"].

Compatibilità con le maniglie

Il sistema di ante scorrevoli rientranti ha un tipo apertura push pull e non è compatibile con maniglie sporgenti.

Characteristics

System of sliding doors retracting into pockets, with two double doors and technical compartment integrated in two single unit bodies, each occupying 15 cm [5 7/8"], giving a total space requirement of 30 cm [11 3/4"].

Feasibility

Systems can be placed side by side or next to any type of base, wall or tall unit or side facing panel reaching down to the floor, directly on the outside of the unit bodies. The external side of the unit body can be left visible.

Constraints

Custom heights, widths and depths are not possible. The system is not suitable for use as a partition wall. Top boxes cannot be installed on top of this system. Side facing panels which do not reach down to the ground cannot be used. For reasons of stability, units (base, wall and tall) must be installed throughout the interior of the system. No type of unit or appliance opening towards the side panel (e.g. units with projecting handles, with perfectly flush hinges, with fridge or oven, wine cellars, etc.) can be installed next to the inside side panels. There must be a gap of at least 2 cm [3/4"] at the top of the system. An empty space at least equal to the width of the front panel + 30 cm [11 3/4"] must be left on the front of the system.

Compatibility with handles

The retracting sliding door system has push-pull opening and is not compatible with projecting handles.

MODULARITÀ vista frontale, laterale e in pianta
MODULARITY front view, side view and plan view

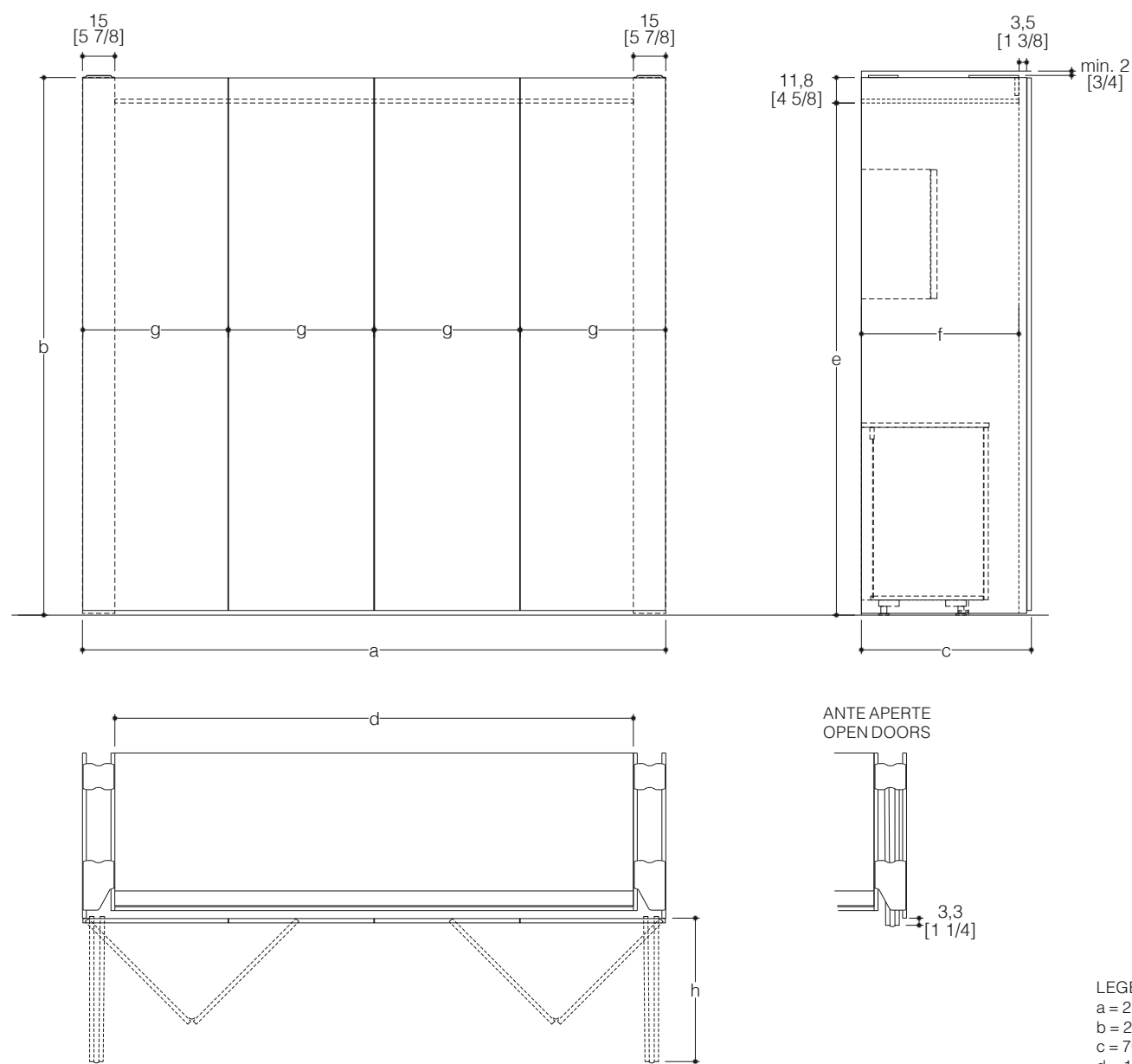

LEGENDA (cm)
a = 210 - 270
b = 213 - 249
c = 70 - 80
d = 180 - 240
e = 201 - 237
f = 63 - 73
g = 52,2 - 67,2
h = 51,5 - 67

KEY TO DIMENSION (inches)
a = 82 5/8 - 106 1/4
b = 83 7/8 - 98
c = 27 1/2 - 31 1/2
d = 94 1/2 - 70 7/8
e = 79 1/8 - 93 1/4
f = 24 3/4 - 28 3/4
g = 20 1/2 - 26 1/2
h = 20 1/4 - 26 3/8

TIPO A a.210 b.213/249 c.70
VANO LIBERO INTERNO d.180cm e.201-237cm f.63

TIPO B a.210 b.213/249 c.80
VANO LIBERO INTERNO d.180cm e.201-237cm f.73

TIPO C a.270 b.213/249 c.80
VANO LIBERO INTERNO d.240cm e.201-237cm f.73

TYPE A a.[82 5/8] b.[83 7/8]/[98] c.[27 1/2]
INTERNAL FREE COMPARTMENT d.[70 7/8] e.[79 1/8]-[93 1/4] f.[24 3/4]

TYPE B a.[82 5/8] e.[83 7/8]/[98] f.[31 1/2]
INTERNAL FREE COMPARTMENT d.[70 7/8] e.[79 1/8]-[93 1/4] f.[28 3/4]

TYPE C a.[106 1/4] e.[83 7/8]/[98] c.[31 1/2]
INTERNAL FREE COMPARTMENT d.[94 1/2] e.[79 1/8]-[93 1/4] f.[28 3/4]

MODULARITÀ vista frontale e laterale
MODULARITY front view and side view

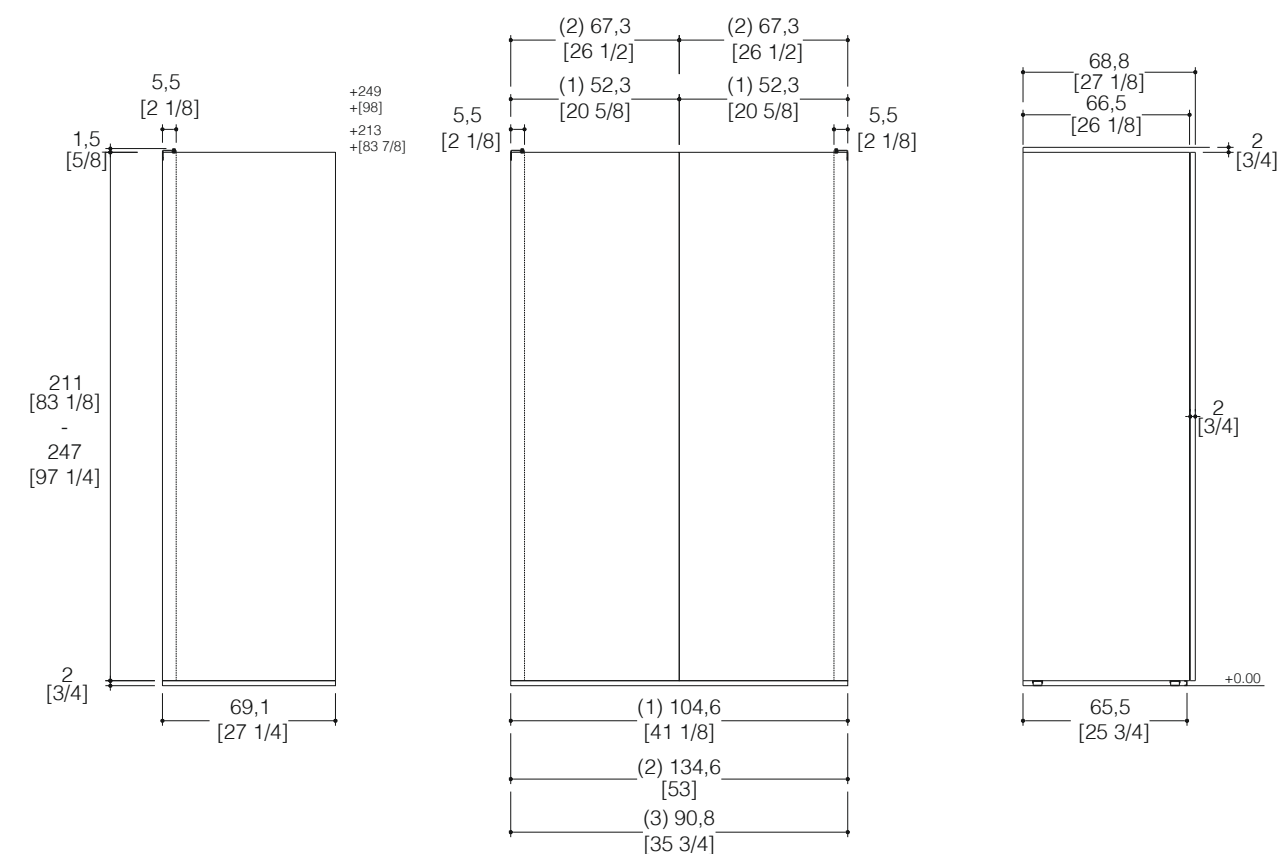

Caratteristiche

Un singolo meccanismo di apertura per singola porta, applicato al fianco, sviluppa un ingombro di 5,5 cm [2 1/8"]. Due meccanismi, sviluppano un ingombro doppio pari a 11 cm [4 3/8"].

Fattibilità

In assenza di copri fianchi, è possibile affiancare armadi standard direttamente ai lati della colonna Indoor. È possibile personalizzare lo schienale dell'armadio Indoor nei materiali e nelle finiture delle ante del programma K-Lab.

Vincoli

Il lato dell'armadio con vano tecnico per il rientro dell'anta, non può mai essere lasciato a vista, deve essere sempre chiuso da parete, da copri fianco o da altro armadio. In assenza di copri fianchi, non è possibile affiancare basi, pensili e colonne basse direttamente ai lati dell'armadio Indoor. Sul lato superiore degli armadi, deve esserci uno spazio minimo di almeno 2 cm [3/4"].

Compatibilità con le maniglie del modello K-Lab

Il sistema di ante rientranti Indoor è compatibile con le maniglie Lever, Nexus, Show.

Characteristics

Just one opening mechanism per door, mounted on the side panel, occupies 5.5 cm [2 1/8"] of space. Two mechanisms occupy twice the space, of 11 cm [4 3/8"].

Feasibility

If side facing panels are not fitted, standard cupboards can be installed directly alongside the Indoor tall unit. The back panel of the Indoor cupboard can be customised with the materials and finishes available for K-Lab programme doors.

Constraints

The side of the cupboard with the cavity which houses the retracting door can never be left bare; it must be covered by a wall, a side facing panel or another cupboard. If side facing panels are not fitted, base, wall and low tall units cannot be installed directly alongside the Indoor cupboard. There must be a gap of at least 2 cm [3/4"] at the top of cupboards.

Compatibility with K-Lab model handles

The Indoor retracting door system is compatible with the Lever, Nexus and Show handles.

MODULARITÀ PENSILI vista frontale e laterale
WALL CABINETS MODULARITY front view and side view

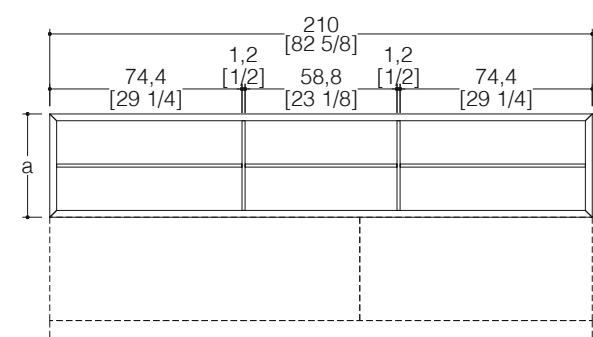
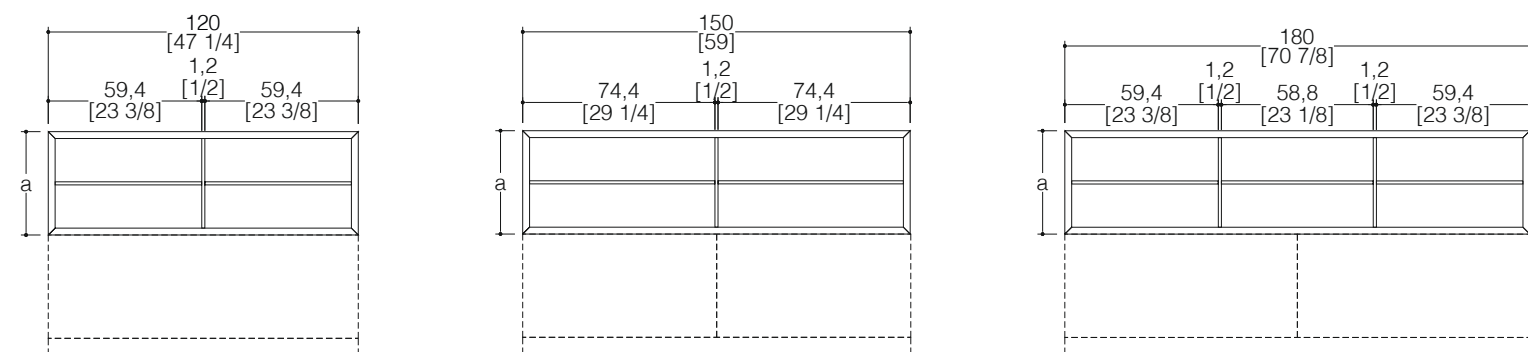

VERSIONE CON PROFONDITÀ BASE RIDOTTA
VERSION WITH REDUCED BASE DEPTH

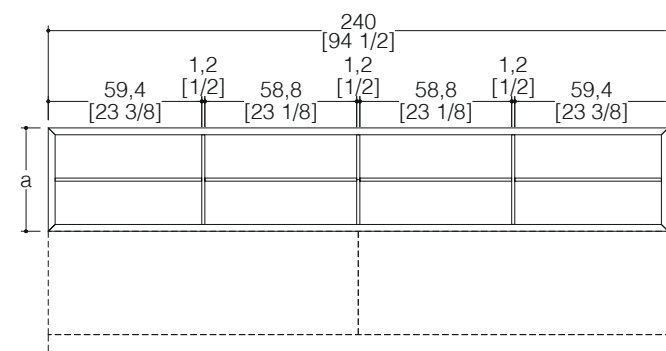
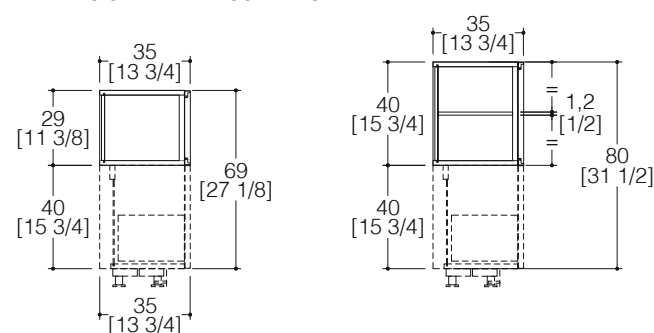

VERSIONE CON PROFONDITÀ BASE STANDARD
VERSION WITH STANDARD BASE DEPTH

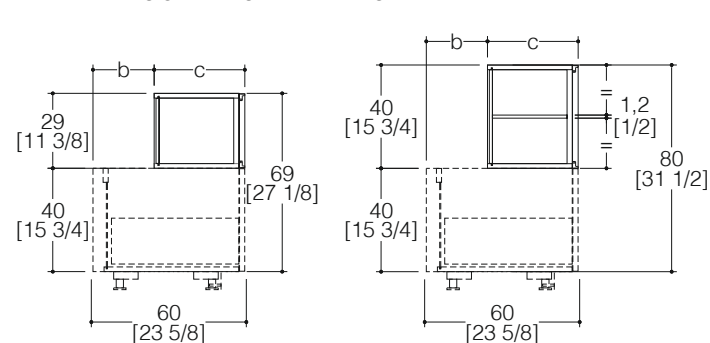

Caratteristiche

Sistema di mobili di contenimento a giorno, basi, pensili e colonne, caratterizzati da una cornice perimetrale in alluminio. I materiali componenti le strutture sono Melamminico e Laccato. Il fondo dei cassetti, laddove presenti, è rivestito in ecopelle. Possibilità di personalizzare la cornice in alluminio nelle finiture laccate del programma Sign.

Fattibilità

Possono essere installati a terra, sospesi, in appoggio su basi dedicate o affiancati indistintamente a basi, pensili e colonne o semplicemente tra loro. La cornice alluminio può essere attrezzata con illuminazione led, attivabile tramite interruttore remoto.

Vincoli

Riduzioni/aumenti dimensionali in altezza, larghezza e profondità, non sono ammessi.

Characteristics

System of open, base, wall and tall units with aluminium surround. Structures are in Melamine and in Lacquered finishes. The bottoms of any drawers are lined with eco-leather. The aluminium surround can be customised in the lacquered finishes of the Sign programme.

Feasibility

Units in this system can be installed on the floor, wall-mounted, resting on special base units, next to base, wall and tall units or simply between them. The aluminium surround can be fitted with Led lighting controlled via a remote switch.

Constraints

No reductions/increases in height, width or depth are permitted.

MODULARITÀ PENSILI vista frontale e laterale
WALL CABINETS MODULARITY front view and side view

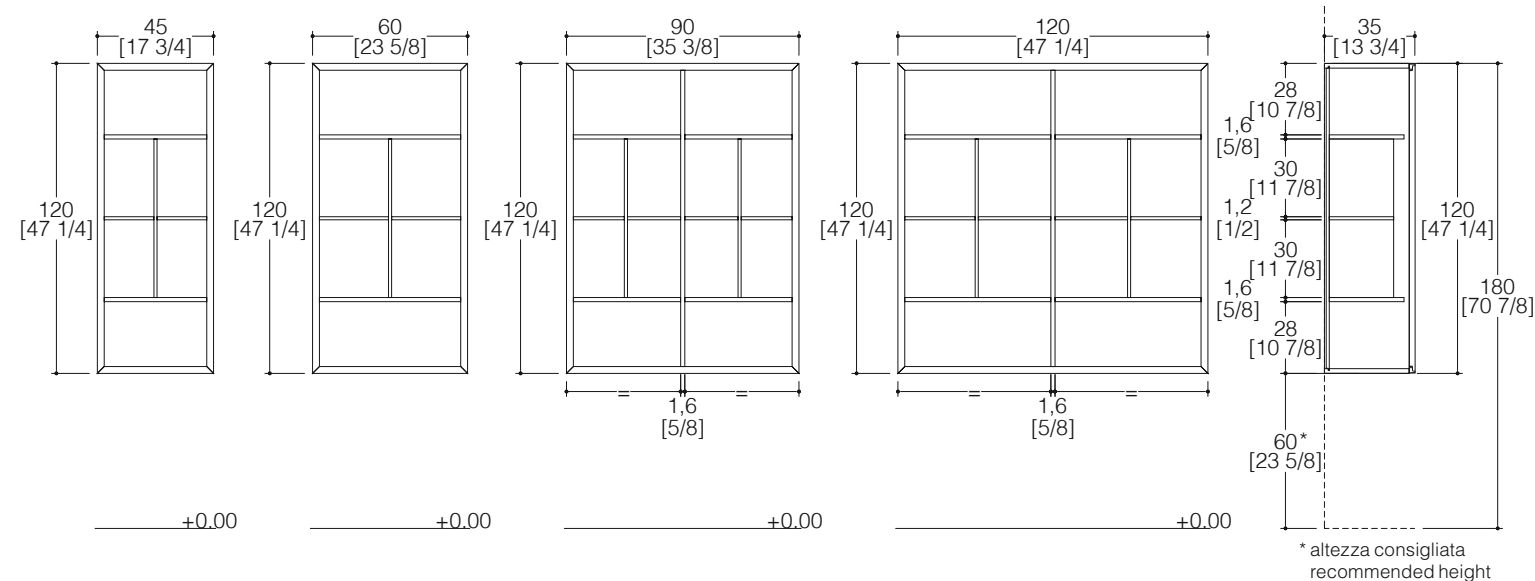
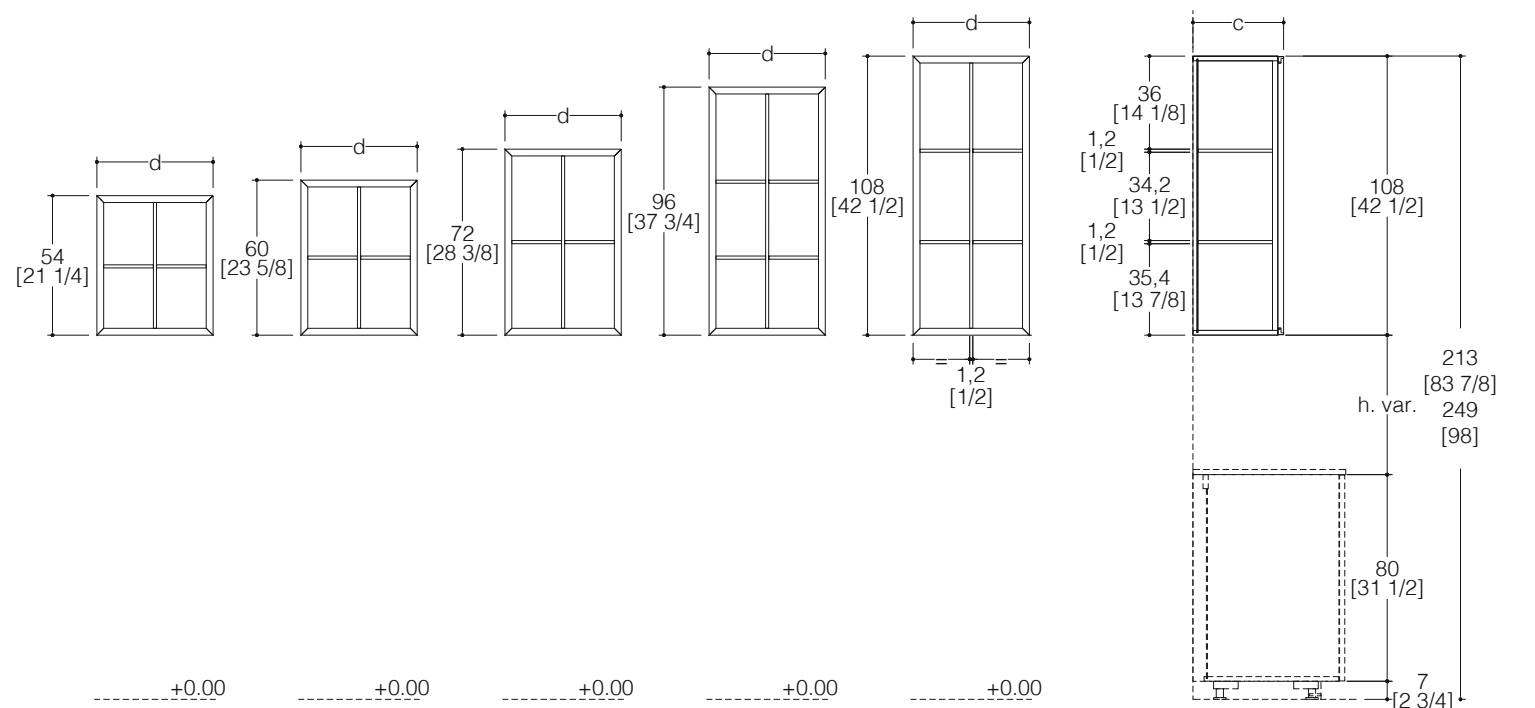

LEGENDA (cm)

- a = 29 - 40
- b = 13,7 - 23,7
- c = 35 - 45
- d = 45 - 60
- e = 18 - 28

KEY TO DIMENSION (inches)

- a = 11 3/8 - 15 3/4
- b = 5 3/8 - 9 3/8
- c = 13 3/4 - 17 3/4
- d = 17 3/4 - 23 5/8
- e = 7 1/8 - 11

* altezza consigliata
recommended height

MODULARITÀ ARMADI STANDARD vista frontale e laterale
STANDARD TALL UNITS MODULARITY front view and side view

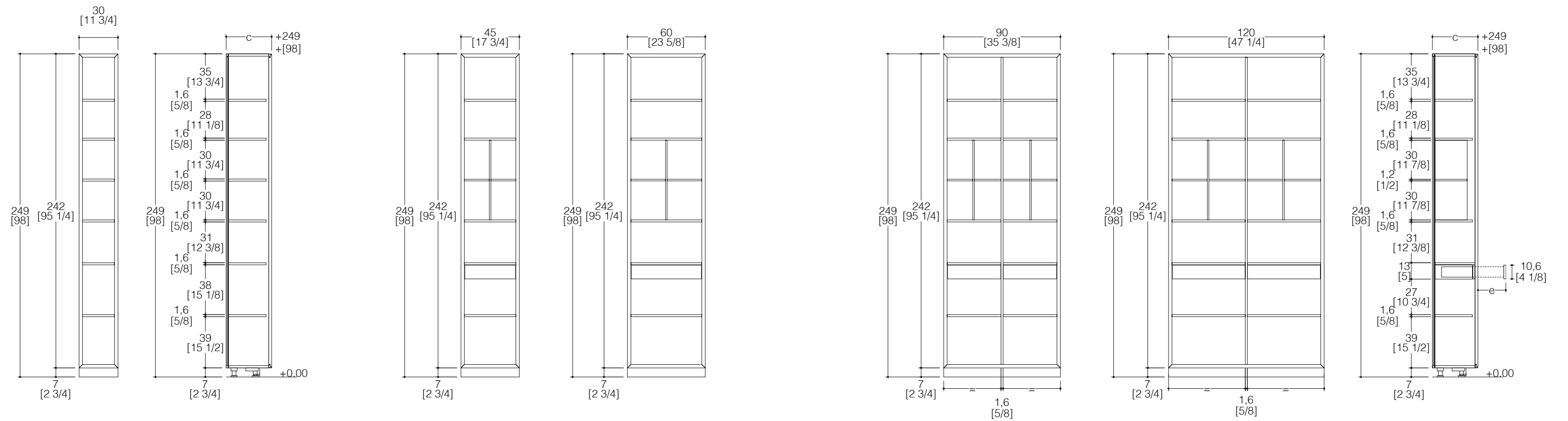
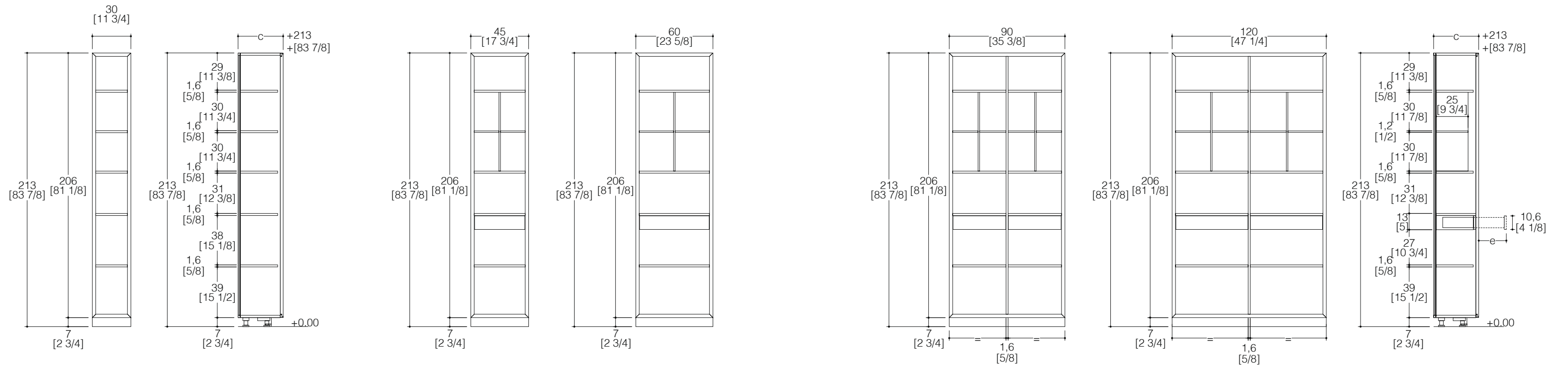

MODULARITÀ ARMADI IN SPACE vista frontale e laterale
IN SPACE TALL UNITS MODULARITY front view and side view

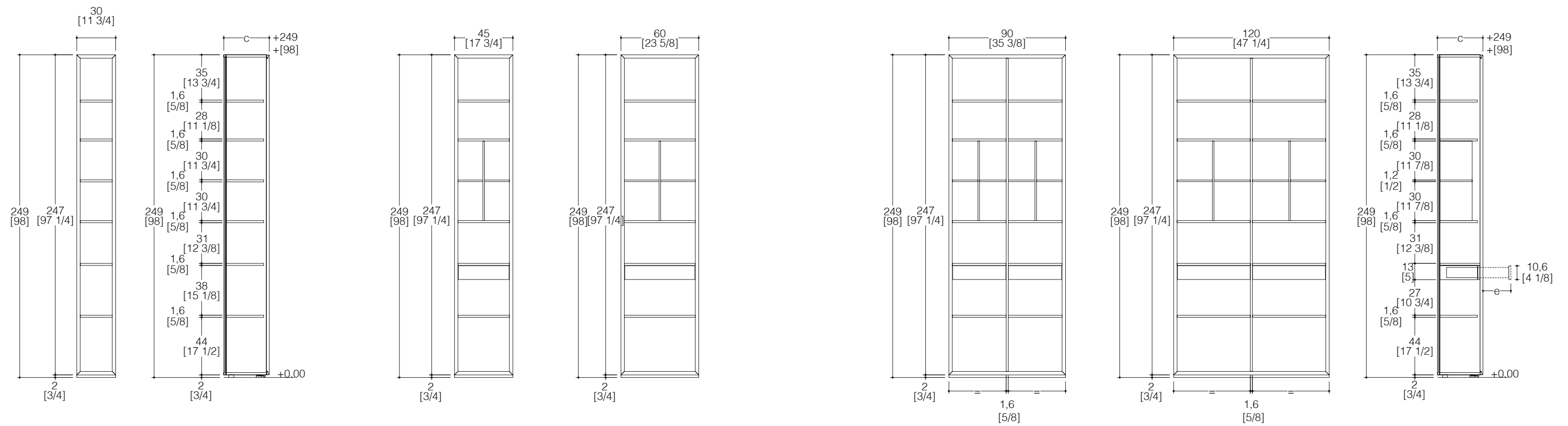
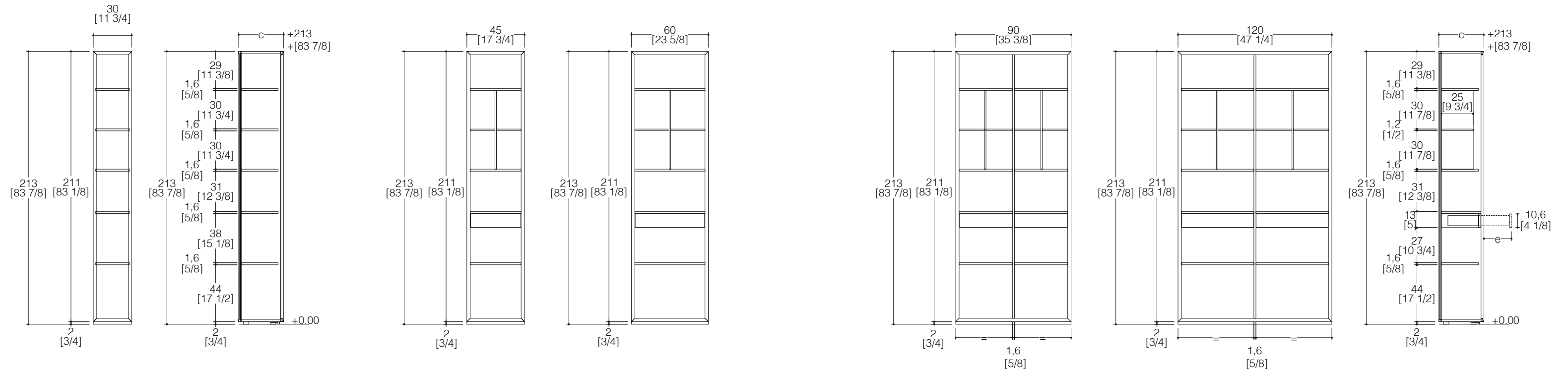

MODULARITÀ vista laterale e in pianta
 MODULARITY side view and plan view

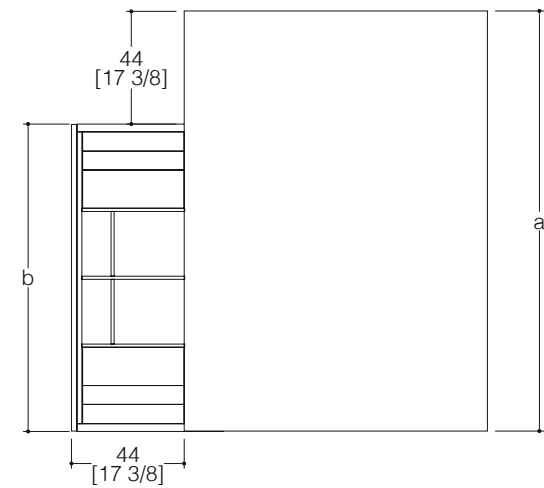
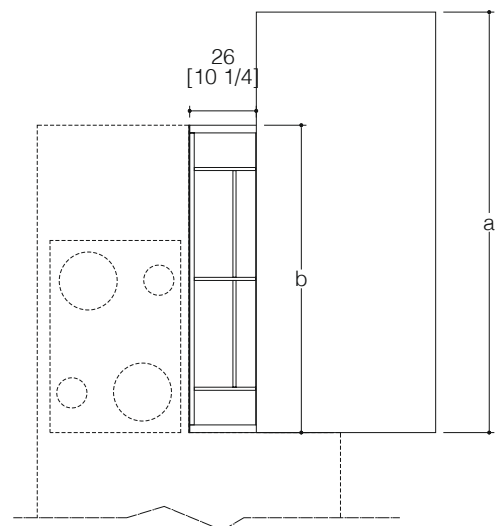
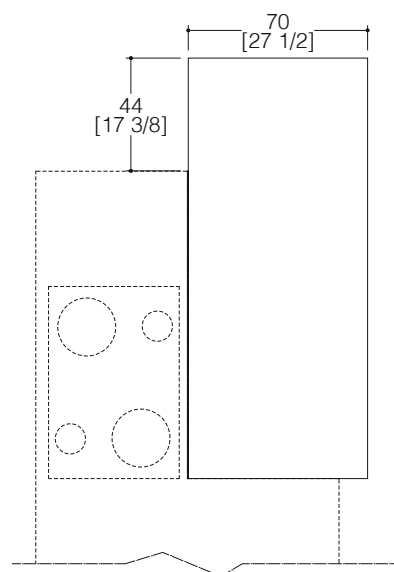
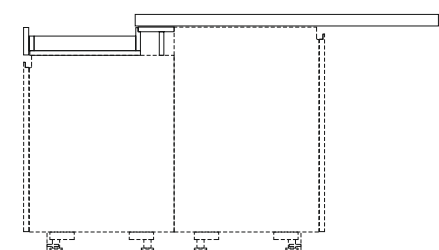
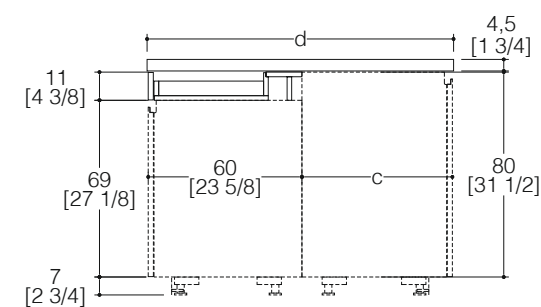
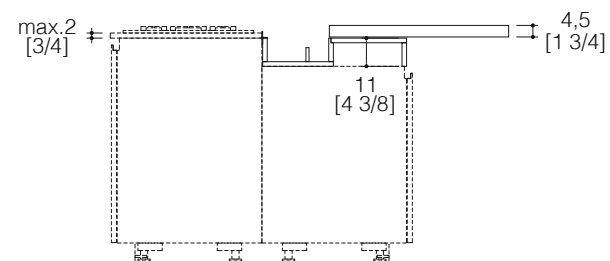
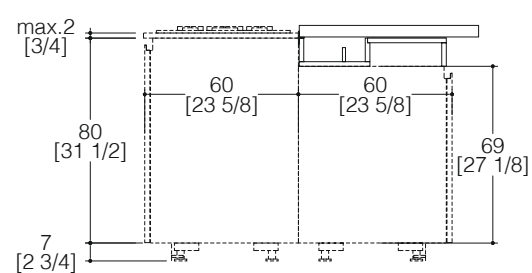
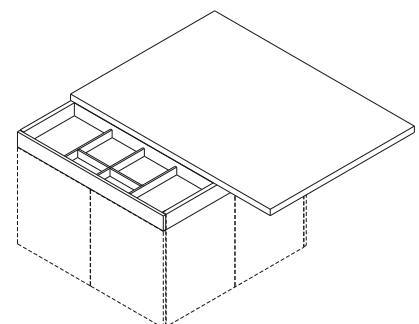
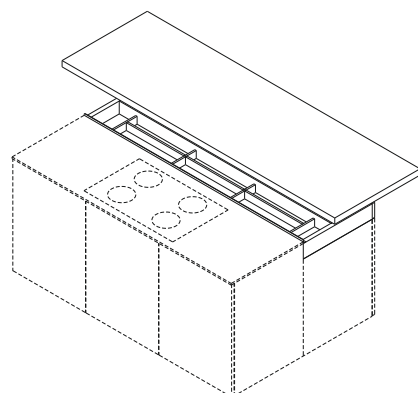

<p>LEGENDA (cm)</p> <p>a = 119 - 134 - 164 - 194 - 224</p> <p>b = 75 - 90 - 120 - 150 - 180</p> <p>c = 35 - 60</p> <p>d = 94,7 - 96,3 - 118,4 - 120</p>	<p>KEY TO DIMENSION (inches)</p> <p>a = 46 7/8 - 52 3/4 - 64 5/8 - 76 3/8 - 88 1/4</p> <p>b = 29 1/2 - 35 3/8 - 47 1/4 - 59 - 70 7/8</p> <p>c = 13 3/4 - 23 5/8</p> <p>d = 37 1/4 - 37 7/8 - 46 5/8 - 47 1/4</p>
---	--

MODULARITÀ vista laterale e in pianta
 MODULARITY side view and plan view

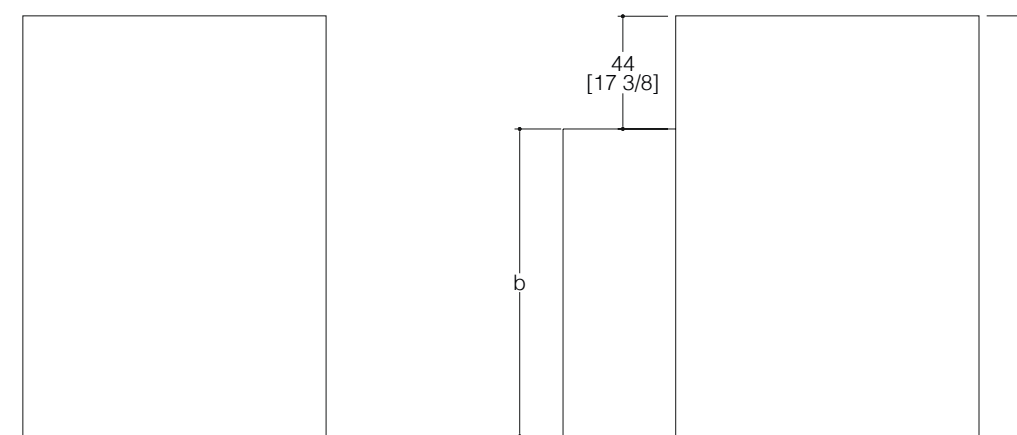
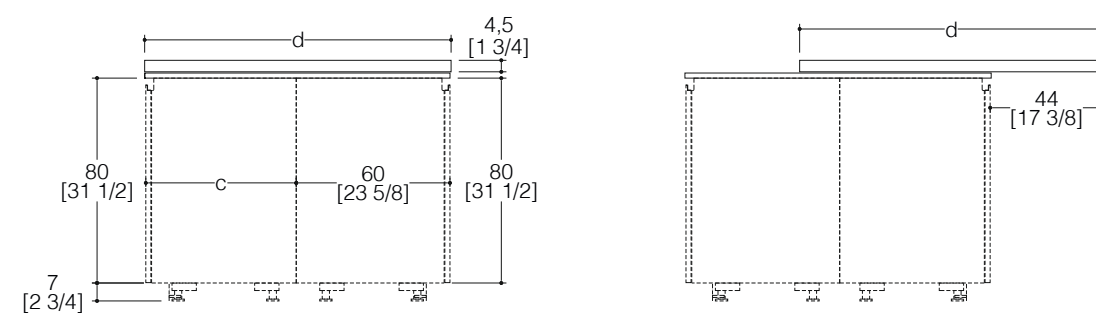
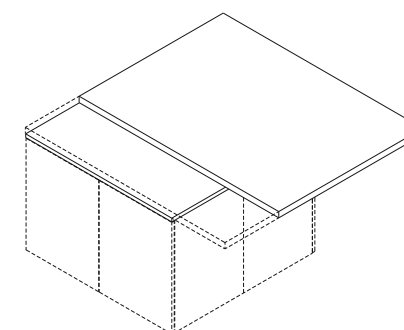
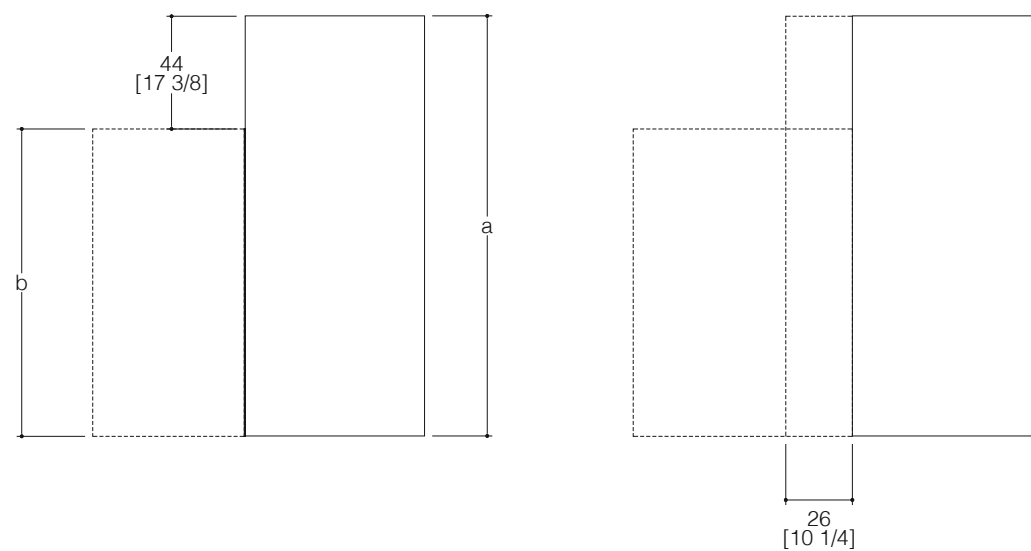
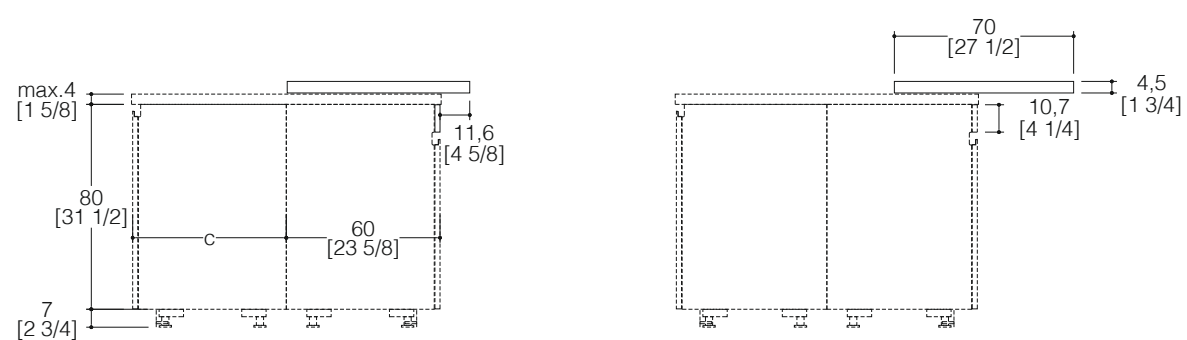
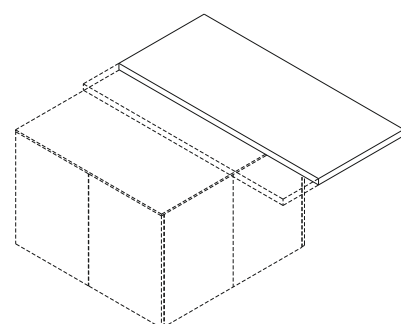

<p>LEGENDA (cm)</p> <p>a = 119 - 134 - 164 - 194 - 224</p> <p>b = 75 - 90 - 120 - 150 - 180</p> <p>c = 35 - 60</p> <p>d = 94,7 - 96,3 - 118,4 - 120</p>	<p>KEY TO DIMENSION (inches)</p> <p>a = 46 7/8 - 52 3/4 - 64 5/8 - 76 3/8 - 88 1/4</p> <p>b = 29 1/2 - 35 3/8 - 47 1/4 - 59 - 70 7/8</p> <p>c = 13 3/4 - 23 5/8</p> <p>d = 37 1/4 - 37 7/8 - 46 5/8 - 47 1/4</p>
---	--

Move-on Plus**Caratteristiche**

Elemento composto da piano scorrevole realizzato al folding spessore 4,5 cm [1 3/4"] nelle profondità 70 - 94,7 - 96,3 - 118,4 - 120 cm [27 1/2" - 37 1/4" - 37 7/8" - 46 5/8" - 47 1/4"] e vano per accessori. Entrambi gli elementi vengono posizionati su basi h 69 - 80 cm [27 1/8" - 31 1/2"] di serie.

Fattibilità

Nel vano per accessori è possibile inserire il sistema Surf e porta prese dedicati.

Vincoli

Non sono realizzabili fuori misura sul piano o sul vano per accessori. Non è possibile inserire elettrodomestici sul piano scorrevole. In presenza del piano scorrevole profondità 70 cm [27 1/2"], sul lato del top opposto allo snack, gli unici piani cottura inseribili sono quelli ad induzione. I piani di lavoro posizionati sul lato opposto al piano Move-on Plus profondità 70 cm [27 1/2"] non possono avere uno spessore superiore ai 2 cm [3/4"]. I piani di lavoro affiancati alla penisola Move-on Plus profondità 94,7 - 96,3 - 118,4 - 120 cm [37 1/4" - 37 7/8" - 46 5/8" - 47 1/4"] non possono avere uno spessore superiore ai 4 cm [1 5/8"], se installati su basi h 80 cm [31 1/2"]. Su basi h 69 cm [27 1/8"] lo spessore dei piani è pari a 15 cm [5 7/8"]. È obbligatoria la presenza del copri fianco sul lato della composizione a vista.

Move-on**Caratteristiche**

Piano scorrevole realizzato al folding spessore 4,5 cm [1 3/4"] nelle profondità 70 - 94,7 - 96,3 - 118,4 - 120 cm [27 1/2" - 37 1/4" - 37 7/8" - 46 5/8" - 47 1/4"], posizionato su basi h 80 cm [31 1/2"] di serie.

Vincoli

Inseribile solamente sopra piani di lavoro spessore 1,2 - 2 cm [1/2 - 3/4"]. Le basi su cui viene inserito il sistema di scorrimento devono prevedere il fisso superiore h 11 cm [4 3/8"]. Non sono realizzabili fuori misura sul piano scorrevole o sulle basi su cui viene montato. Non è possibile inserire elettrodomestici sul piano scorrevole. È obbligatoria la presenza del copri fianco sul lato della composizione a vista.

Move-on Plus**Characteristics**

Element consisting of folded melamine sliding top 4.5 cm [1 3/4"] thick in depths 70 - 94.7 - 96.3 - 118.4 - 120 cm [27 1/2" - 37 1/4" - 37 7/8" - 46 5/8" - 47 1/4"] and accessories compartment. Both elements are for installation on base units h 69 - 80 cm [27 1/8" - 31 1/2"] as standard.

Feasibility

The Surf system and specific socket strips can be installed in the accessories compartment.

Constraints

Custom sizes are not available for the top or the accessories compartment. No appliances can be installed on the sliding top. With sliding top having depth 70 cm [27 1/2"], induction hobs are the only type which can be installed on the side of the top opposite the snactop. Worktops on the opposite side to the Move-on Plus top depth 70 cm [27 1/2"] cannot be more than 2 cm [3/4"] thick. Worktops alongside the Move-on Plus peninsula depth 94.7 - 96.3 - 118.4 - 120 cm [37 1/4" - 37 7/8" - 46 5/8" - 47 1/4"] cannot be more than 4 cm [1 5/8"] thick if installed over base units h 80 cm [31 1/2"]. On base units h 69 cm [27 1/8"], worktop thickness is 15 cm [5 7/8"]. Side facing panels must be fitted on the visible sides of the composition.

Move-on**Characteristics**

Sliding top consisting of folded melamine sliding top 4.5 cm [1 3/42"] thick in depths 70 - 94.7 - 96.3 - 118.4 - 120 cm [27 1/2" - 37 1/4" - 37 7/8" - 46 5/8" - 47 1/4"], installed on base units h 80 cm [31 1/2"] as standard.

Constraints

Can only be installed on top of worktops with thickness 1.2 - 2 cm [1/2 - 3/4"]. Base units on which the sliding system is installed must have fixed front panel at top h 11 cm [4 3/8"]. Custom sizes are not available for the sliding top or for the base units on which it is installed. No appliances can be installed on the sliding top. Side facing panels must be fitted on the visible sides of the composition.

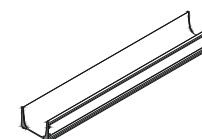
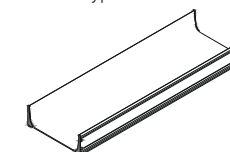
ACCESSORI PER VANI SURF
ACCESSORIES FOR SURF COMPARTMENTSmodulo tipo "A"
module type "A"modulo tipo "B"
module type "B"accessori per modulo tipo "A"
accessories for module type "A"

(1)

accessori per modulo tipo "B"
accessories for module type "B"

(2)

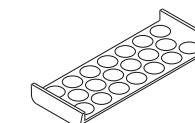

(5)

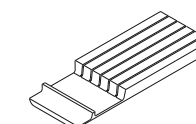

(3)

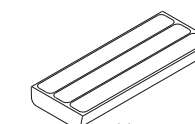

(6)

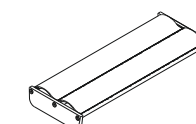

(4)

LEGENDA (cm)

- 1 = spalletta divisorio per mod. "A" 6,7 x 1,5 cm
- 2 = spalletta divisorio per mod. "B" 14,1 x 1,5 cm
- 3 = portacoltelli 14,1 x 37 cm
- 4 = portapellicole 14,1 x 37 cm
- 5 = porta capsule caffè 14,1 x 37 cm
- 6 = porta spezie 14,1 x 37 cm

KEY TO DIMENSION (inches)

- 1 = partition for module type "A" [2 5/8 x 5/8]
- 2 = partition for module type "B" [5 1/2 x 5/8]
- 3 = knife rack [5 1/2 x 14 5/8]
- 4 = kitchen film holder [5 1/2 x 14 5/8]
- 5 = rack f/espresso caps [5 1/2 x 14 5/8]
- 6 = spice rack [5 1/2 x 14 5/8]

ACCESSORI PER VANI LIBERI
ACCESSORIES FOR FREE COMPARTMENTS**LEGENDA (cm)**

- 7 = bilancia digitale 26,4 x 20,1 cm
- 8 = presa elettrica 11,7 x 11,7 cm

KEY TO DIMENSION (inches)

- 7 = digital scale [10 3/8 x 7 7/8]
- 8 = electric socket [4 5/8 x 4 5/8]

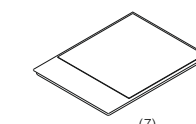

(7)



(8)

NOTA

Per la configurazione degli scomparti interni fare riferimento alle pagine del listino

Refer to the pricelist pages for the configuration of the internal compartments

MODULARITÀ vista in pianta e assonometrica
 MODULARITY plan view and assonometric view

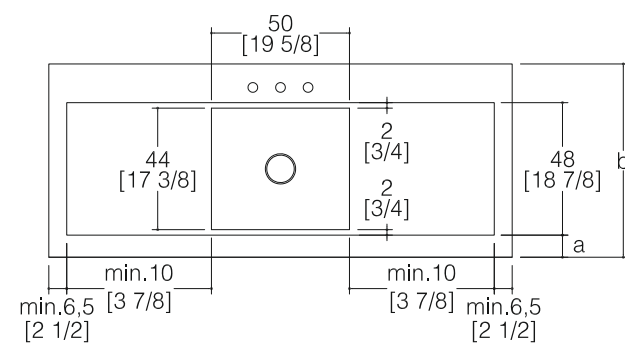
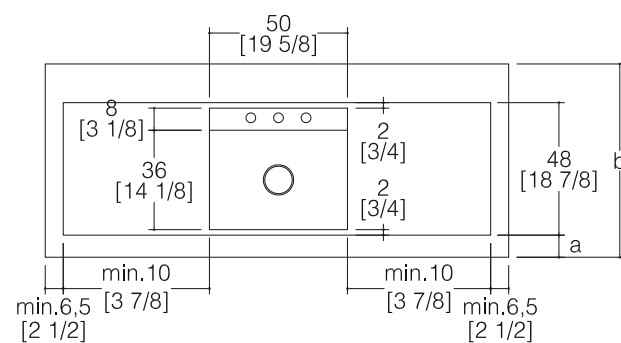
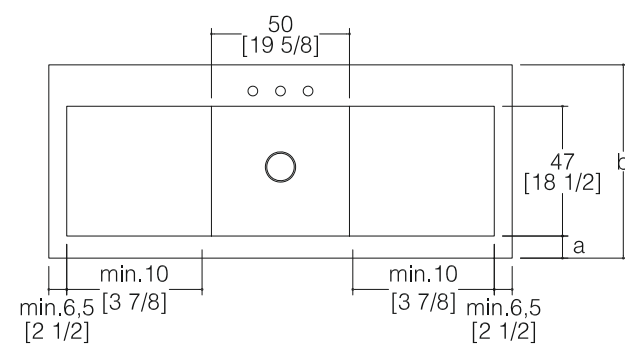
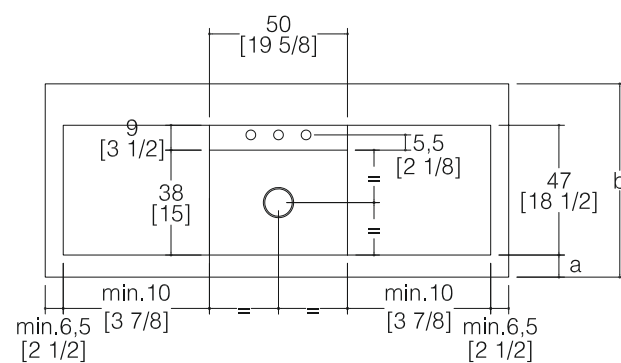
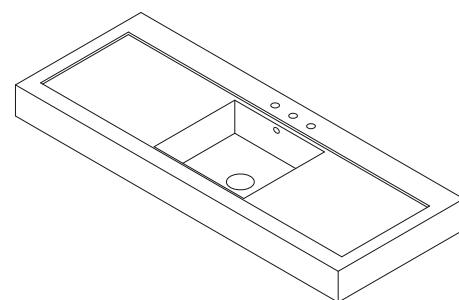
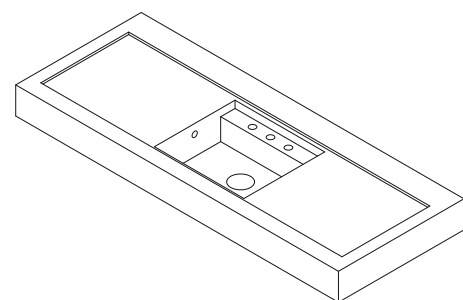

LEGENDA (mm) KEY TO DIMENSION (mm)

QUARZ - ICONCRETE - STONE+

	thickness top	a	b
SMALL	≥40	92	592
	≥40		617
	all		692
	all		717
	all		792
	≥40		947
STANDARD	≥40	100	600
	≥40		625
	all		700
	all		725
	all		800
	≥40		963
	≥40		1200

ACCIAIO

	thickness top	a	b
SMALL	all	72	592
	all		617
	all		692
	all		717
	all		792
	all		947
STANDARD	all	80	600
	all		625
	all		700
	all		725
	all		800
	all		963
	all		1200

LAMINATE/FENIX

	thickness top	a	b
SMALL	all	92	692
	all		717
	all		792
STD	all	100	700
	all		725
	all		800

MODULARITÀ vista in pianta e assometrica
 MODULARITY plan view and assonometric view

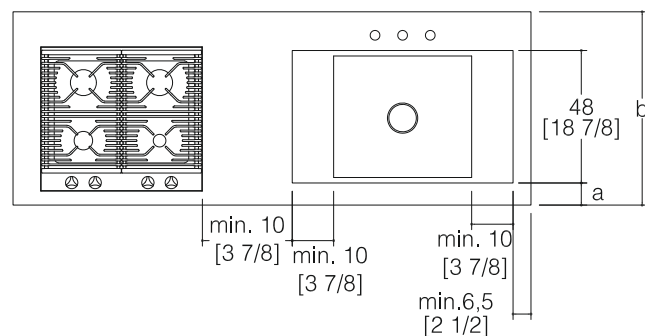
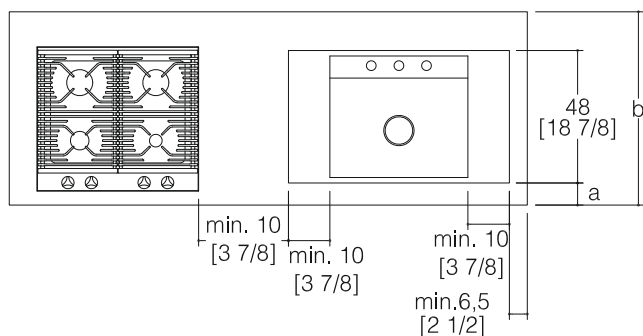
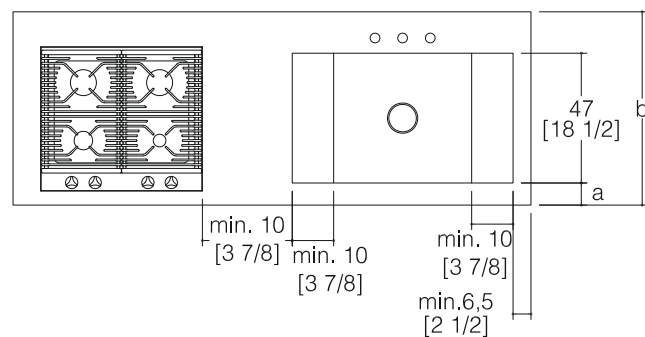
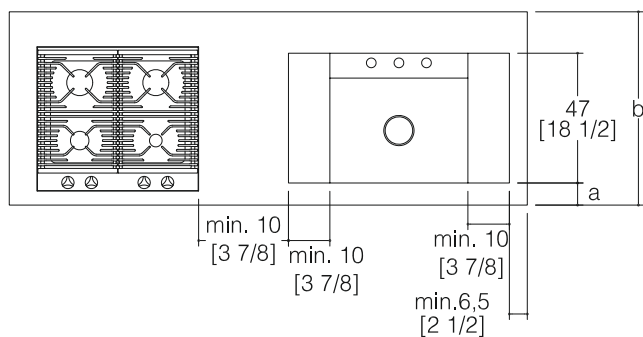
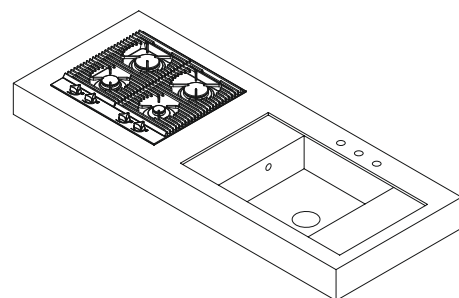
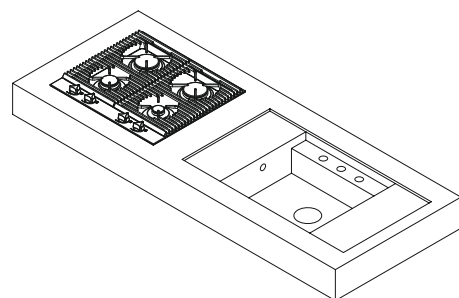

INGRANDIMENTO ZONA LAVAGGIO vista in pianta
 LARGEMENT OF THE WASHING AREA plan view

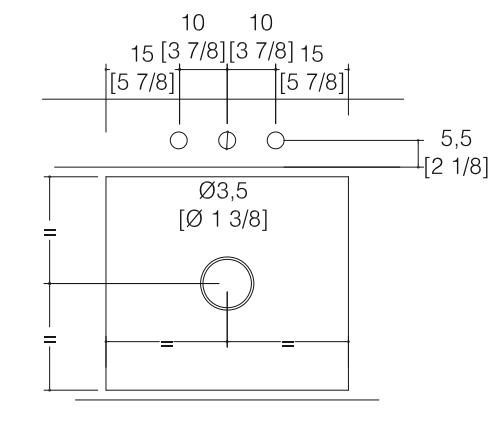
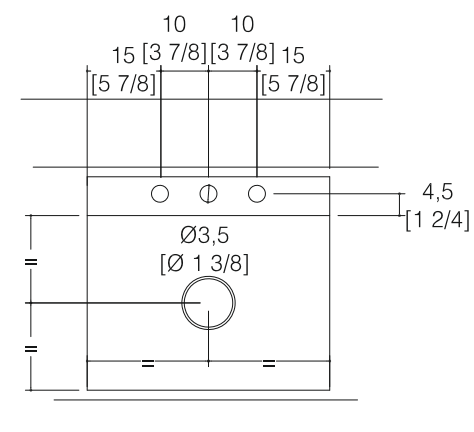
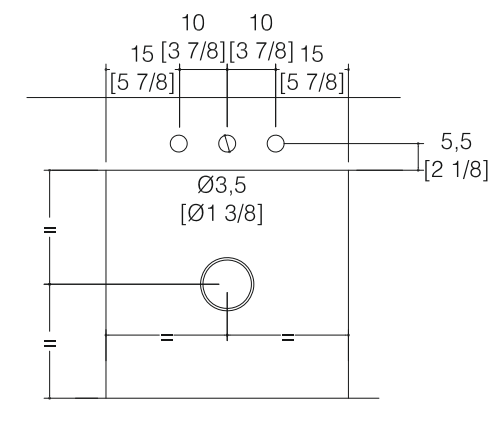
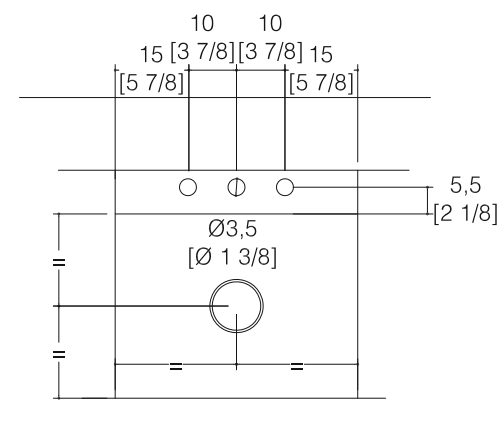

MODULARITÀ vista in pianta e assonometrica
 MODULARITY plan view and assonometric view

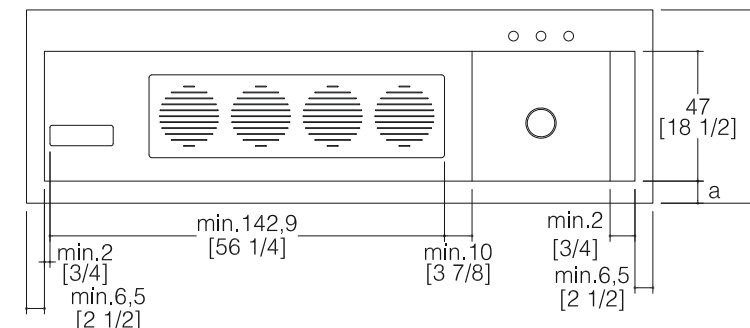
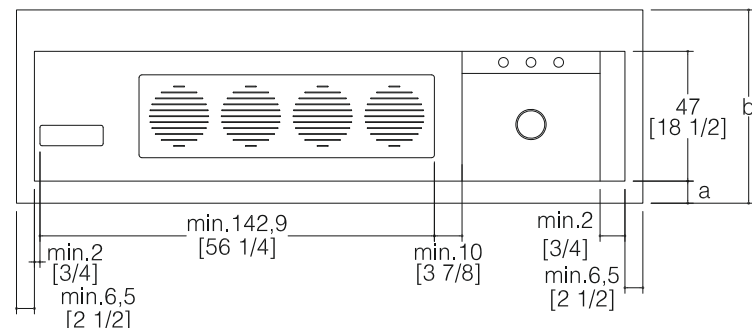
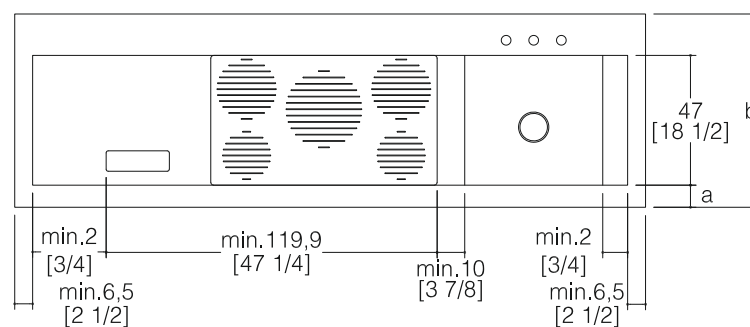
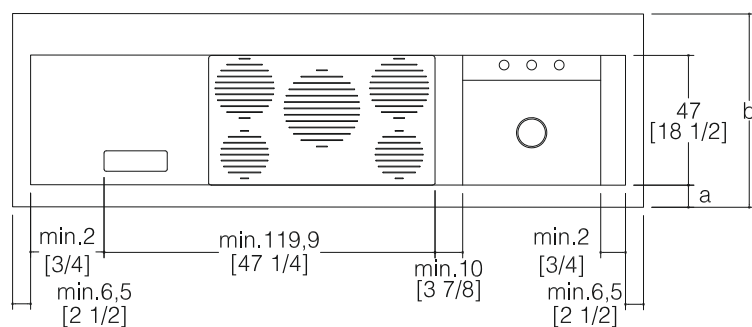
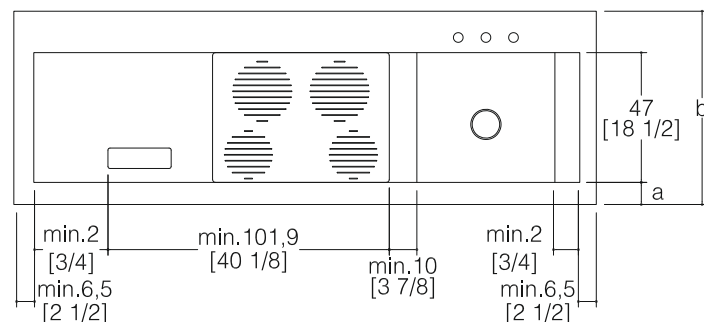
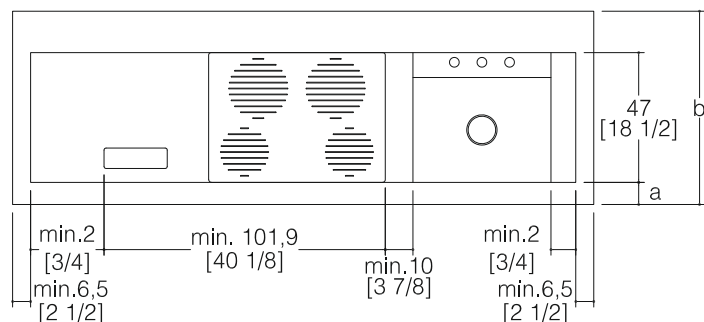
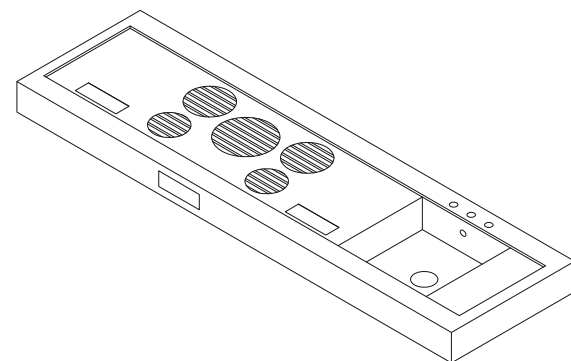
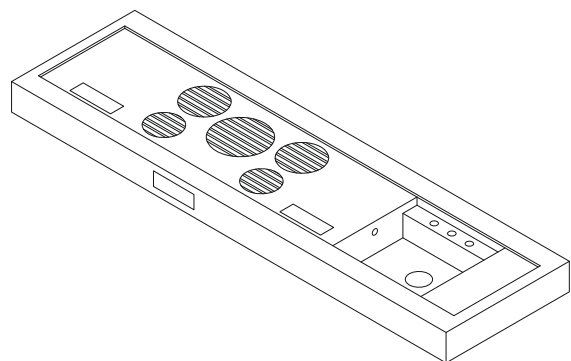

Zona invaso Able

Caratteristiche

Può essere inserito su tutti i profili piano, ha uno spessore di 1,2 cm [1/2"] ed è realizzato nello stesso materiale del piano di lavoro: Acciaio, Fenix, Laminato, ICONcrete, Quarzo MDI e Stone+.
 Le profondità del piano di lavoro sono: 60 cm [23 5/8"], 64 cm [25 1/4"], 70 cm [27 1/2"], 74 cm [29 1/8"], 80 cm [31 1/2"], 96,3 cm [37 7/8"] e 120 cm [47 1/4"].

Fattibilità

Per l'acciaio la profondità dell'invaso è di 48 cm [18 7/8"] mentre per tutti gli altri materiali è di 47 cm [18 1/2"].

Vincoli

L'invaso Able può essere posizionato ad una distanza minima dal fianco della base sottostante di 6,5 cm [2 1/1"]. Nell'invaso Able possono essere inserite unicamente zone lavaggio e zone cottura dedicate.

Zona lavaggio Able

Caratteristiche

Progettata come zona operativa esclusiva dell'invaso Able. La zona lavaggio è realizzata nello stesso materiale del piano di lavoro. I materiali piano in cui può essere sviluppata sono: Acciaio, Fenix, Laminato, ICONcrete, Quarzo e Stone+. Può essere costruita con comandi su console o con comandi su piano.

Fattibilità

Per gli inserimenti della zona lavaggio sui vari piani in base agli spessori e alle varie profondità fare riferimento alle tabelle sottostanti.

Vincoli

Le zone lavaggio con comandi su piano possono essere inserite solo su basi profondità 70 cm [27 1/2"]. Tra la zona cottura e la zona lavaggio deve esserci una distanza minima di 10 cm [3 7/8"].

Able recessed zone

Characteristics

Can be installed on all worktop profiles, is 1.2 cm [1/2"] thick, and is in the same material as the worktop: Steel, Fenix, Laminate, ICONcrete, Quartz, MDI and Stone+.
 Worktop depths are: 60 cm [23 5/8"], 64 cm [25 1/4"], 70 cm [27 1/2"], 74 cm [29 1/8"], 80 cm [31 1/2"], 96.3 cm [37 7/8"] e 120 cm [47 1/4"].

Feasibility

For steel, the depth of the recessed zone is 48 cm [18 7/8"]; for all other materials it is 47 cm [18 1/2"].

Constraints

The Able recessed zone must be at least 6.5 cm [2 1/1"] from the side of the base unit underneath. Only specific washing and cooking zones can be installed inside the Able recessed zone.

Able washing zone

Characteristics

Designed exclusively for the Able recessed zone. The washing zone is in the same material as the worktop. The item can be produced in Steel, Fenix, Laminate, ICONcrete, Quartz and Stone+. Can be constructed with controls on console or directly on worktop.

Feasibility

For installation of the washing zone on the various worktops with different thicknesses and depths, refer to the table below.

Constraints

Washing zones with controls on worktop can only be installed on base units depth 70 cm [27 1/2"]. The cooking and washing zones must be at least 10 cm [3 7/8"] apart.

MODULARITÀ vista in pianta e assonometrica
MODULARITY plan view and isometric view

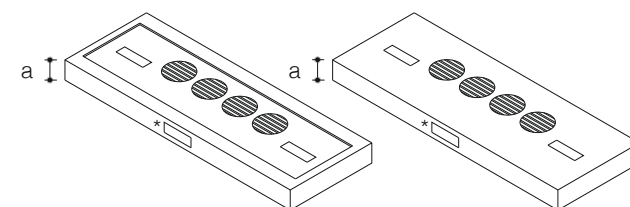
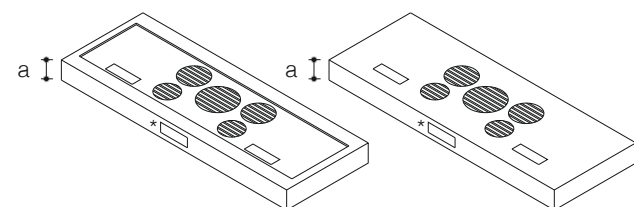
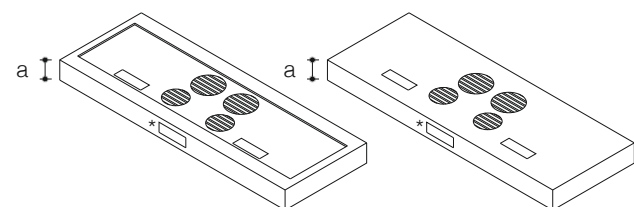

* possibilità di incasso dei comandi in posizione frontale con spessore minimo del piano da 15cm
possibility of recessing the controls in the front position with a minimum thickness of the the top of 15 7/8 inc.

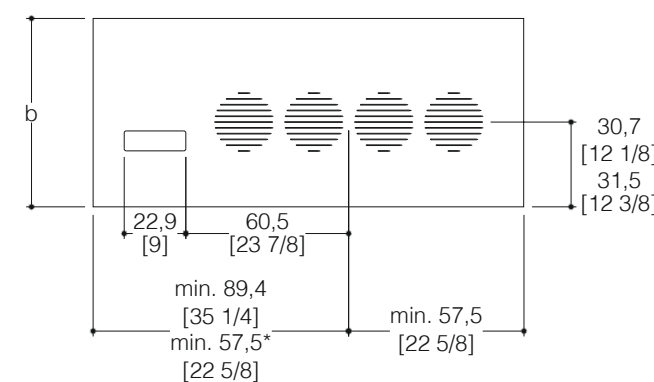
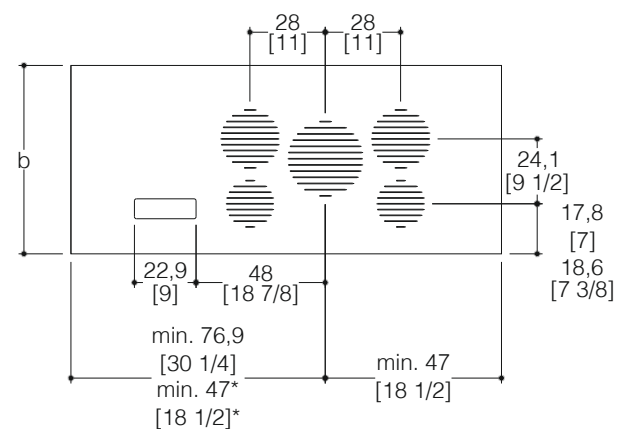
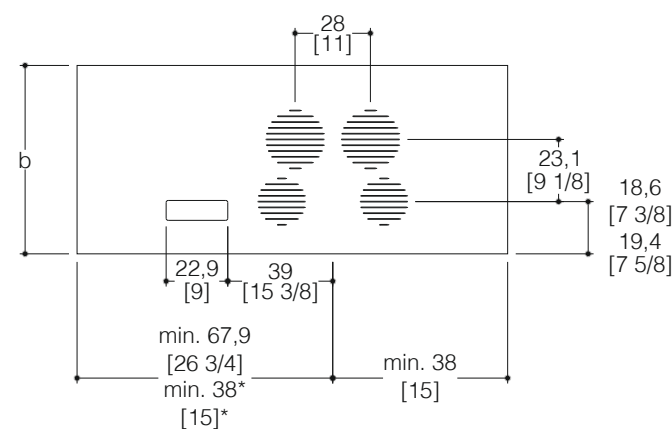
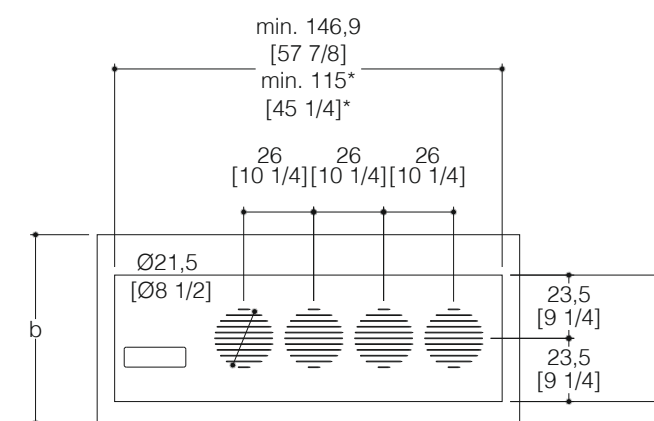
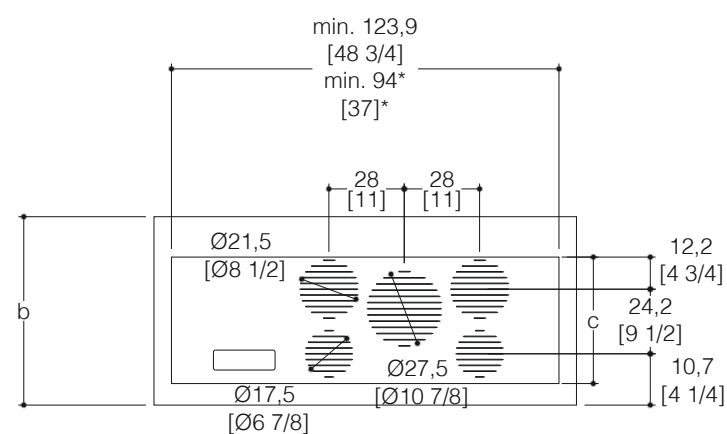
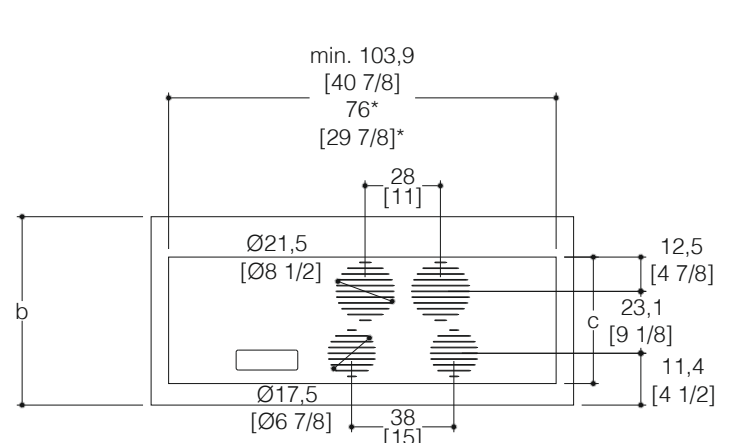

* per piano con comandi posizionati frontalmente
for top with front positioned controls

LEGENDA (cm)
a = min. 4 - max 21,2
b = 59,2 - 60 - 69,2 - 70 - 79,2 - 80 - 94,7 - 96,3 - 118,4 - 120
c = 47

KEY TO DIMENSION (inches)
a = min. 1 5/8 - max. 8 3/8
b = 23 1/4 - 23 5/8 - 27 1/4 - 27 1/2 - 31 1/8 - 31 1/2 - 37 1/4 - 37 7/8 - 46 5/8 - 47 1/4
c = 18 1/2

Caratteristiche

Zona Cottura a induzione sotto piano realizzata unicamente in materiale MDI.

Fattibilità

La zona cottura MDI può essere realizzata in tre tipologie: 4 fuochi, 5 fuochi e 4 fuochi in linea. Può essere inserita sia direttamente a filo top che all'interno dell'invaso Able. La pulsantiera touch del piano cottura può essere posizionata lateralmente o frontalmente alla zona cottura.

Vincoli

La pulsantiera touch del piano cottura è posizionabile sul bordo frontale del piano solo se questo è di spessore 15 cm [5 7/8"] o superiore. Distanza minima di 10 cm [3 7/8"] da una zona lavaggio/lavello. Disponibilità solo per Mercato CE.

Characteristics

Undermount induction cooking zone constructed only in MDI material.

Feasibility

The MDI cooking zone is available in three versions: 4 or 5 burners and 4 burners in-line. It can be installed either directly flush with the worktop or inside the Able recessed area. The hob's touch button control board can be installed at the side or front of the cooking zone.

Constraints

The hob's touch button control board can only be installed on the front edge of the worktop if the latter is 15 cm [5 7/8"] thick or more. This element must be at least 10 cm [3 7/8"] from any washing zone/sink. Only available for European Union market.

MODULARITÀ vista frontale e in pianta
MODULARITY front view and plan view

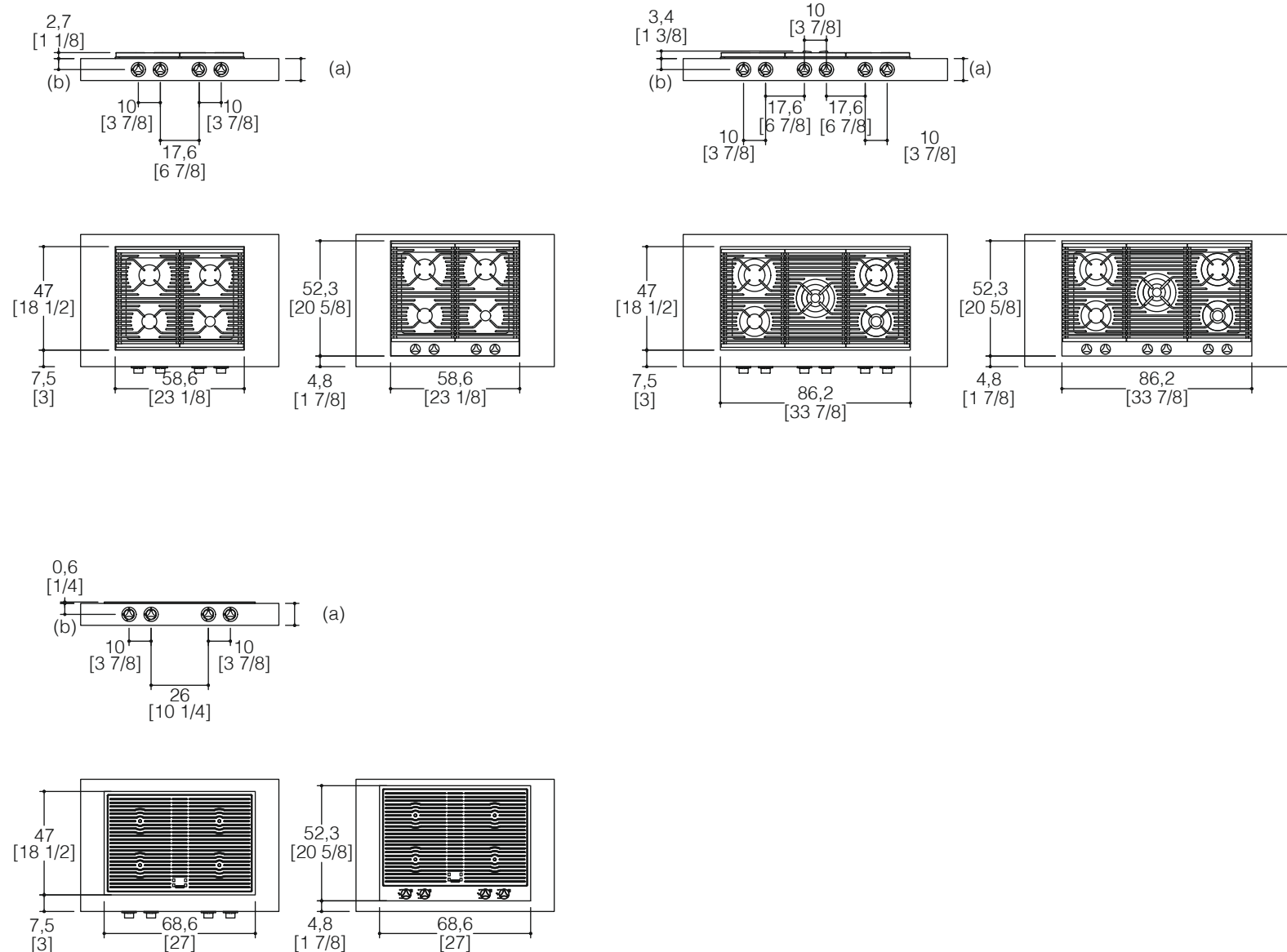

Caratteristiche

Disponibile nelle dimensioni 60 cm [23 5/8"] e 90 cm [35 3/8"] a gas e 70 cm [27 1/2"] ad induzione. Può essere da incasso o saldato, con comandi integrati o sul bordo frontale del piano di lavoro.

Vincoli

Disponibile solo per mercato CE. I piani cottura con comandi frontali sono inseribili solo su piani di spessore (a) maggiore di 10 cm [3 7/8"], nei piani Dual la quota (b) è di 7,5 cm [3"] mentre in tutti gli altri piani è di 5 cm [2"]. I piani cottura con comandi frontali non possono essere spostati in profondità e saranno quindi posizionati come indicato a disegno.

Characteristics

Available in sizes 60 cm [23 5/8"] and 90 cm [35 3/8"] gas version and 70 cm [27 1/2"] induction version. It can be built-in or welded, with controls incorporated or on the front edge of the worktop.

Constraints

Only available for European Union market. Hobs with controls in front edge of worktop can only be installed on worktops having thickness (a) over 10 cm [3 7/8"]; in Dual worktops the dimension (b) is 7.5 cm [3"] while for all other worktops it is 5 cm [2"]. Hobs with controls in front edge of worktop cannot be installed at different depths, and will therefore be placed as shown in the drawing.

MODULARITÀ vista frontale e laterale
MODULARITY front view and side view

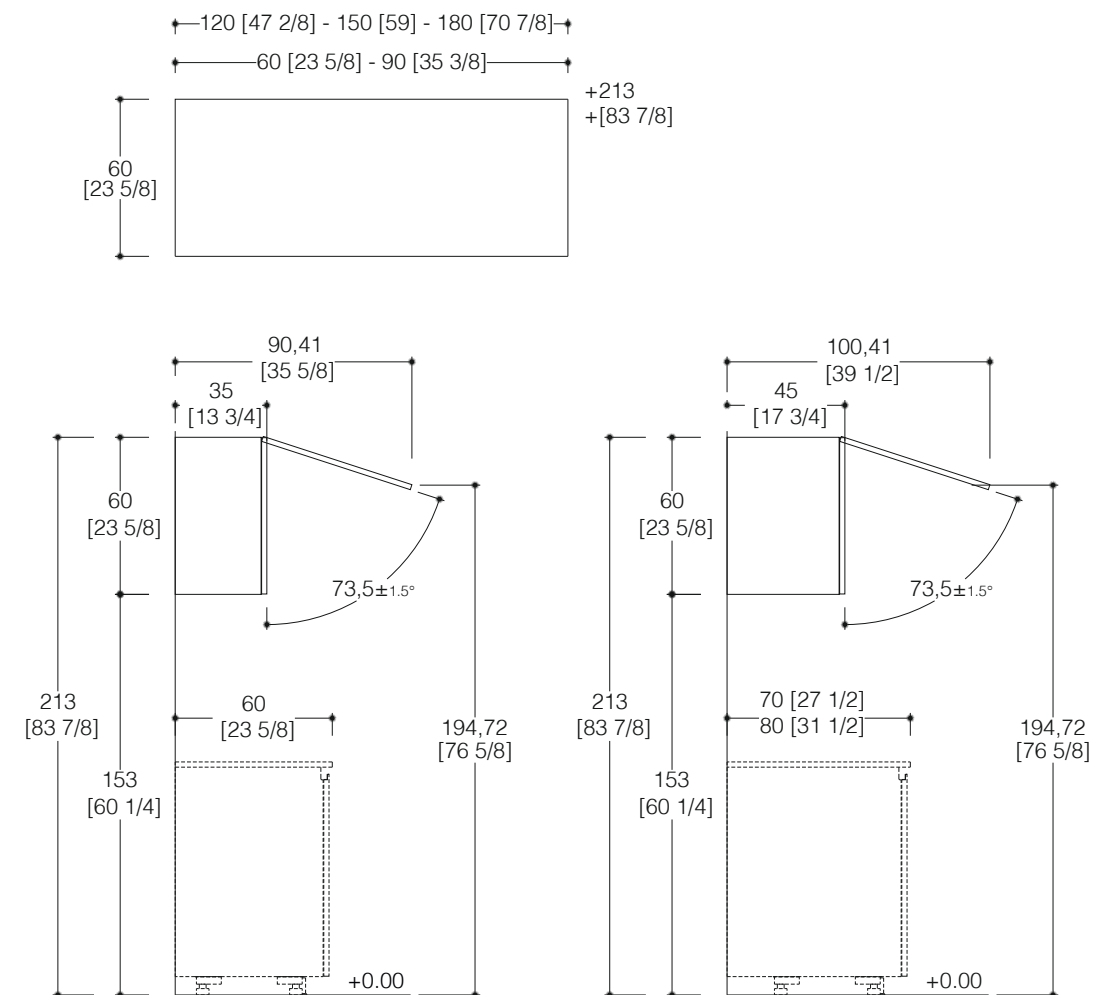

Caratteristiche

È possibile personalizzare la struttura nelle finiture melamminiche del programma Sign. È possibile personalizzare il fianco del pensile nelle finiture legno o laccate del programma Sign e in telaio alluminio e vetro come l'anta. È possibile personalizzare lo schienale e il divisorio nelle finiture legno del programma Sign.

Vincoli

Riduzioni/aumenti dimensionali in altezza, larghezza e profondità, impiego di sopra pensili o cappelli in appoggio non sono ammessi. Non è possibile affiancare il fianco in vetro ad un qualsiasi mobile o a muro, è necessario lasciare un vuoto di almeno 5 cm [2"].

Characteristics

The structure can be customised in the melamine finishes of the Sign programme. The side of the In Line wall unit can be customised with the wood or lacquered finishes of the Sign programme, and in glass with aluminium frame to match the door. The back panel and partition can be customised with the Sign programme wood finishes.

Constraints

Reductions/increases in height, width and depth and the use of top boxes or rest-on top shelves are not permitted. Glass side panels cannot be placed directly next to any item of furniture or a wall: a gap of at least 5 cm must be left [2"].

MODULARITÀ vista frontale e laterale
MODULARITY front view and side view

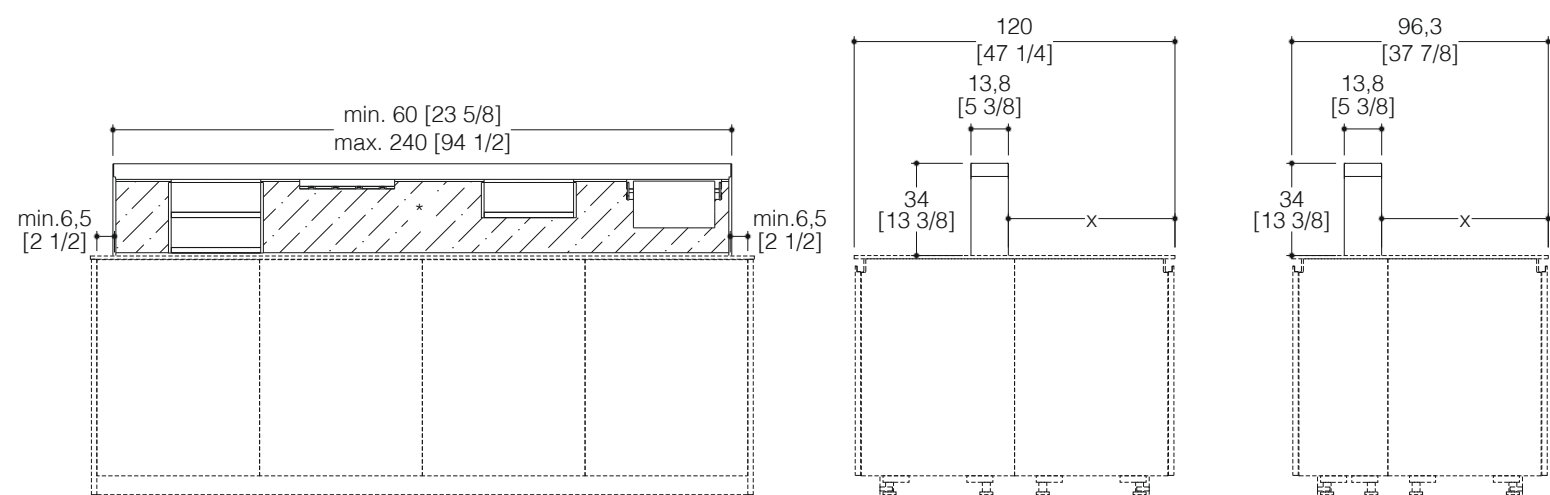

* Schienale vetro opzionale
Optional glass back

LEGENDA (cm)
x = 61,5 - 62,3

KEY TO DIMENSION (inches)
x = 24 1/4 - 24 1/2

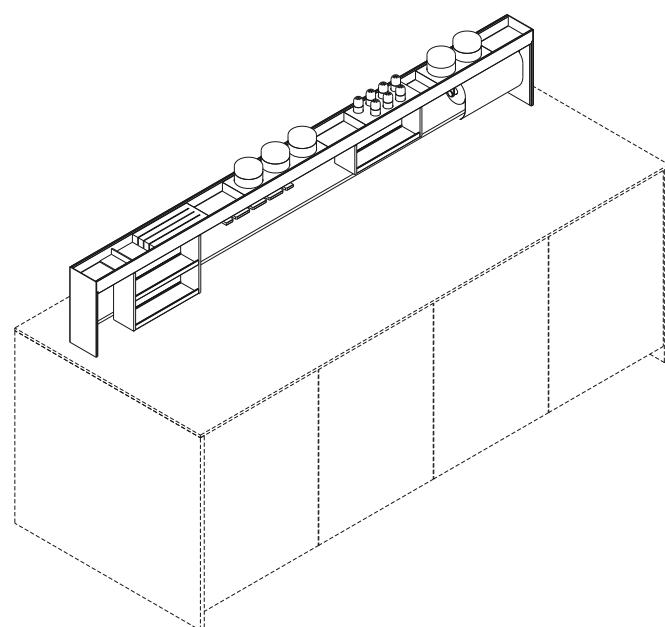

Caratteristiche

Il Canale in alluminio Bridge viene fissato al piano di lavoro ed è concepito per ottimizzare lo spazio di lavoro per i piani ad isola. La distanza dal bordo frontale del piano di lavoro è fissa per garantire un corretto utilizzo degli accessori e del canale.

Fattibilità

Può essere attrezzato con schienale divisorio in vetro, accessori in legno, accessori in alluminio e con illuminazione led, attivabile tramite interruttore remoto. Per le finiture degli accessori legno fare riferimento al listino.

Vincoli

La lunghezza minima è di 60 cm [23 5/8"] mentre la lunghezza massima è di 240 cm [94 1/2"]. Può essere installato solo su piani ad isola con profondità 96,3 cm [37 7/8"] e 120 cm [47 1/4"]. La distanza minima dal bordo laterale del piano è di 6,5 cm [2 1/2"].

Characteristics

The Bridge tidy system consists of an aluminium channel fixed to the worktop, and is designed to optimise workspace on island worktops. The distance from the front edge of the worktop is constant, to ensure correct use of the accessories and tidy system.

Feasibility

Can be fitted with glass back partition, wood and aluminium accessories and Led lighting controlled via a remote switch. Refer to the price list of the finishes of wood accessories.

Constraints

Minimum length is 60 cm [23 5/8"] and maximum length is 240 cm [94 1/2"]. It can only be installed on island worktops with depth 96,3 cm [37 7/8"] and 120 cm [47 1/4"]. The minimum distance from the side edge of the worktop is 6.5 cm [2 1/2"].

ACCESSORI
ACCESSORIES

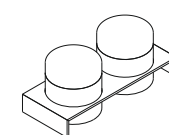

(a1)

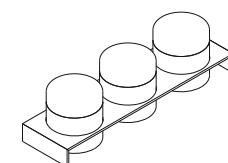

(a2)

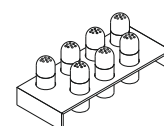

(b)

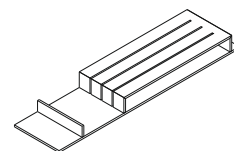

(c)

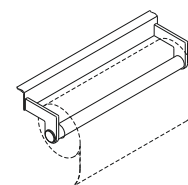

(d)

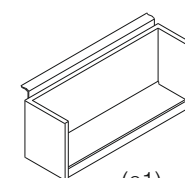

(e1)

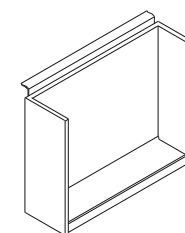

(e2)

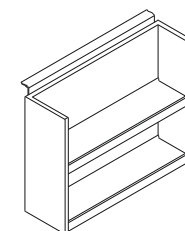

(e3)

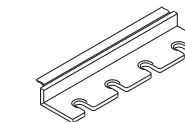

(f)

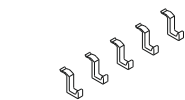

(g)

LEGENDA (cm)

a = porta barattoli 28,6 (a1) 47,3 (a2) x 11,7 cm
b = porta spezie 28,6 x 11,7 cm
c = porta coltelli 47,3 x 11,7 cm
d = portarotolo 35 x 8,4 cm
e = scaffaletto 35 x 13 cm (e1) - 35 x 26 cm (e2-e3)
f = porta bicchieri 35 x 4,3 cm
g = ganci 4,8 x 4,3 cm

KEY TO DIMENSION (inches)

a = can holder [11 1/4 (a1) 18 5/8 (a2) x 4 5/8]
b = spice holder [11 1/4 x 4 5/8]
c = knife holder [18 5/8 x 4 5/8]
d = roll holder [13 3/4 x 3 1/4]
e = rack [13 3/4 x 5 1/8] (e1) - [13 3/4 x 10 1/4] (e2-e3)
f = glass rack [3 3/4 x 1 3/4]
g = hangers [1 7/8 x 1 3/4]

NOTA

Gli accessori dalla lettera "a" alla lettera "c" sono da inserire nel canale, mentre dalla "d" alla "g" sono da appendere

The accessories from letter "a" to "c" are to be inserted in the channel, while from "d" to "g" are to be hung

vista frontale e laterale
front view and side view

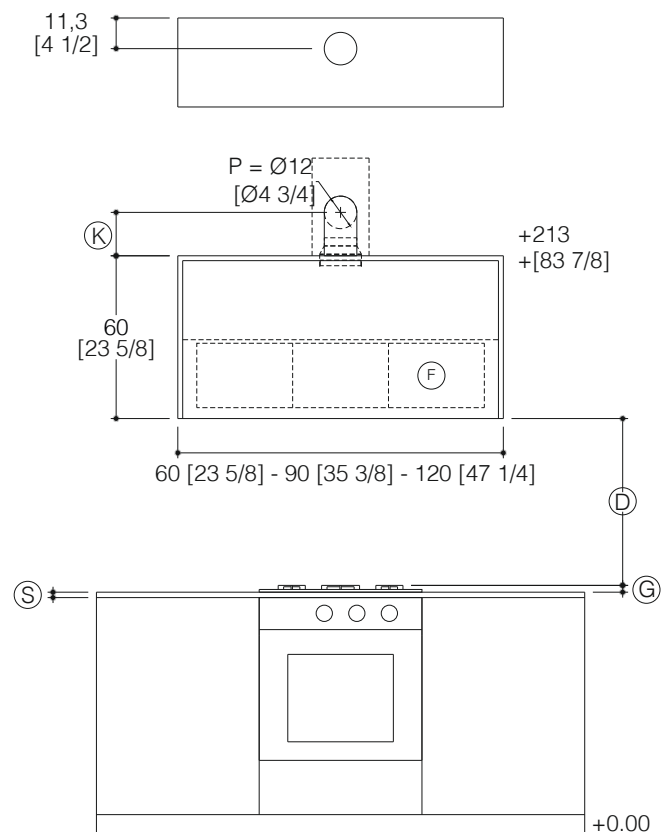

VERSIONE ASPIRANTE
EXTRACTOR VERSION

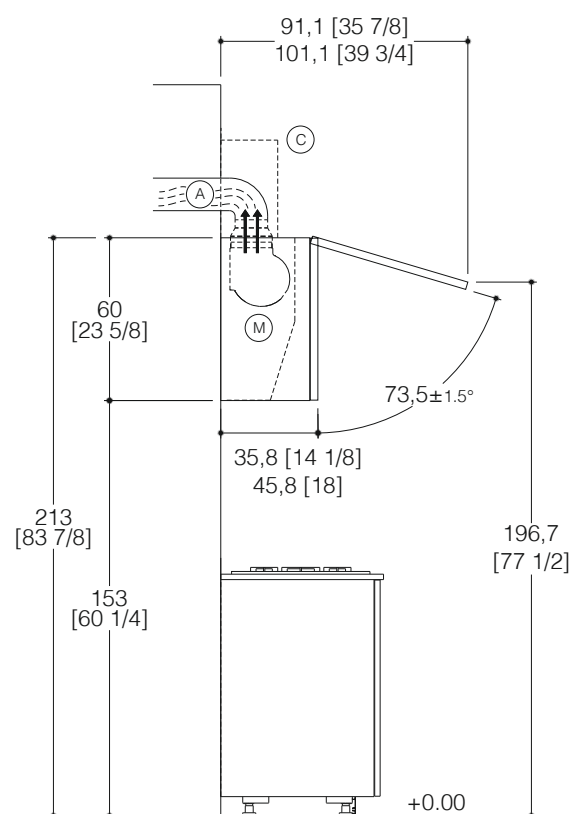

VERSIONE FILTRANTE
FILTERING VERSION

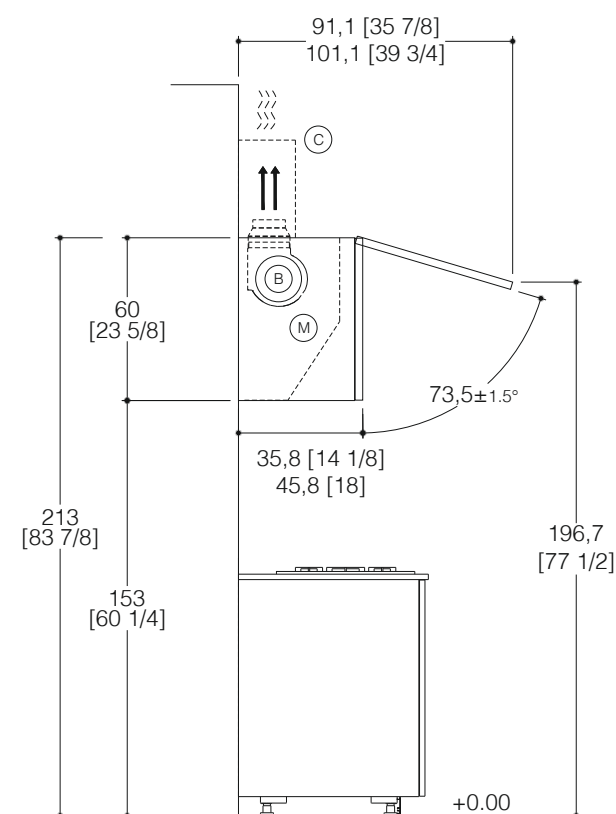

Caratteristiche

- (M) Motore cappa.
- (A) Tubo corrugato in alluminio ø12 cm [4 3/4"] per fuoriuscita aspirazione fumi (versione aspirante).
- (P) Diametro foro parete per tubo di aspirazione.
- (C) Carter in acciaio inox telescopico (opzionale).
- (K) Distanza per foro a parete aspirazione fumi, uguale o superiore a 16 cm [6 1/4"].
- (D) Distanza minima griglie piano cottura - fondale cappa 50 cm [19 5/8"].
- (G) Altezza griglie piano cottura.
- (S) Spessore piano di lavoro.
- (F) Filtri metallici antigrasso.

(B) Kit filtrante a carbone per purificazione fumi (versione filtrante).
È possibile personalizzare il fianco della cappa Hood in line nelle finiture legno e nelle finiture laccate del programma Sign.

Vincoli

Riduzioni/aumenti dimensionali in altezza, larghezza e profondità, impiego di sopra pensili o cappelli in appoggio non sono ammessi.

Characteristics

- (M) Hood motor.
- (A) Corrugated aluminium pipe ø12 cm [4 3/4"] for fume exhaust (ducted version).
- (P) Diameter of hole in wall for extractor pipe.
- (C) Telescopic stainless steel casing (optional).
- (K) Distance for fume exhausting hole in wall, at least 16 cm [6 1/4"].
- (D) Minimum gap between hob pan stands - base of hood 50 cm [19 5/8"].
- (G) Hob pan stand height.
- (S) Worktop thickness.
- (F) Metal grease trap filters.
- (B) Carbon filter kit for fume purification (filter version).

The side of the Hood in line hood can be customised with the wood and lacquered finishes available for the Sign programme.

Constraints

Reductions/increases in height, width and depth and the use of top boxes or rest-on top shelves are not permitted.

CAPPA AD ISOLA ASPIRANTE CON ASPIRAZIONE LATERALE vista frontale e laterale
DUCTED ISLAND HOOD WITH SIDE ASPIRATION front view and side view

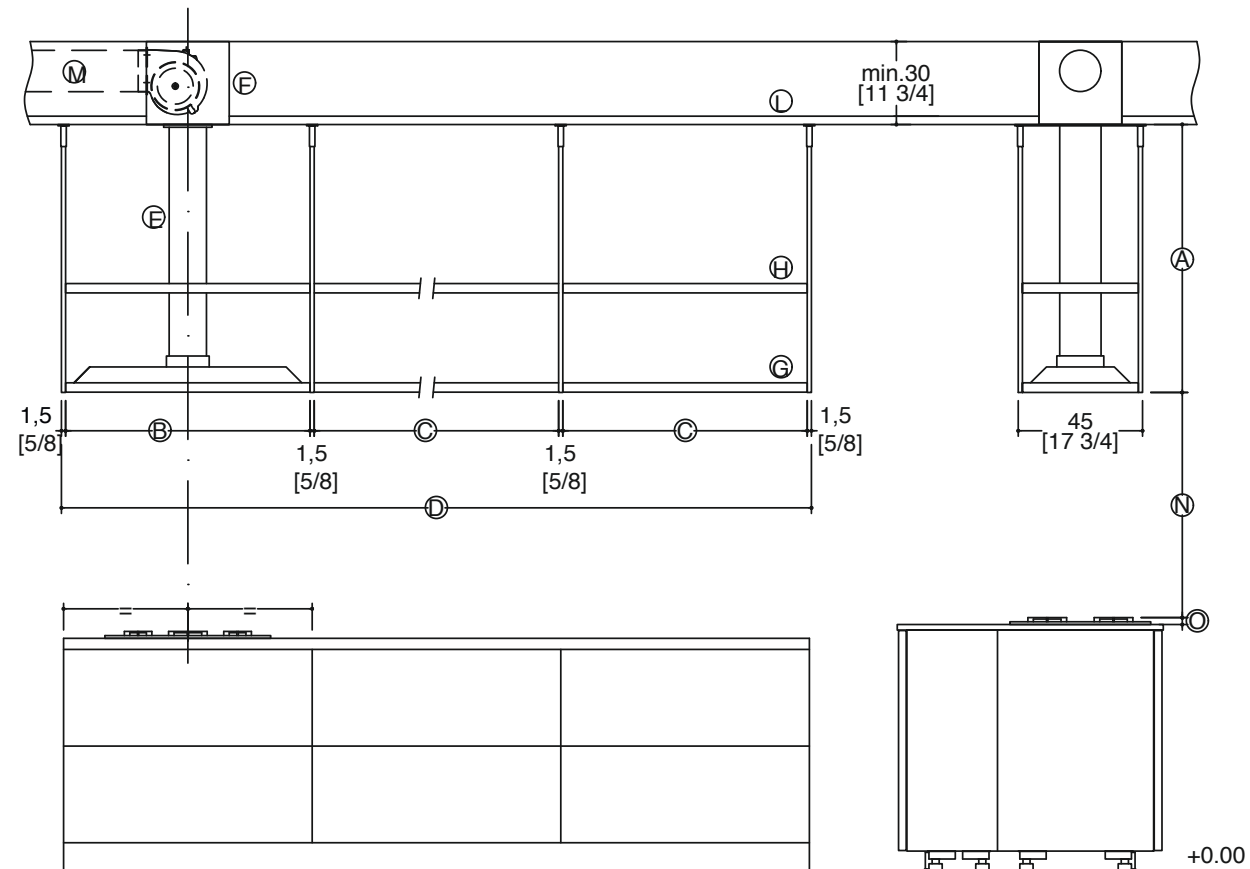

Caratteristiche

- (A) Altezza cappa 67 - 97 cm [26 3/8" - 38 1/4"].
- (B) Larghezza modulo cappa 88,5 - 118,5 cm [34 7/8" - 46 5/8"].
- (C) Larghezza modulo libero 58,5 - 88,5 - 118,5 cm [23" - 34 7/8" - 46 5/8"].
- (D) Larghezza cappa min. 240 - max. 420 cm [min. 94 1/2" - max. 165 3/8"].
- (E) Tubo d'aspirazione ø13,5 cm [ø5 3/8"].
- (F) Motore elettrico.
- (G) Ripiano inferiore dotato di illuminazione LED LINE.
- (H) Ripiano superiore (opzionale - disponibile solo per cappa h. 97 [38 1/4"]-).
- (I) Spalla in acciaio portante.
- (L) Controsoffitto.
- (M) Tubo corrugato in alluminio ø15 cm [5 7/8"].
- (N) Distanza minima griglie piano cottura - fondale cappa 55 cm [21 5/8"].
- (O) Altezza griglie piano cottura.

Characteristics

- (A) Hood height 67 - 97 cm [26 3/8" - 38 1/4"].
- (B) Hood module width 88.5 - 118.5 cm [34 7/8" - 46 5/8"].
- (C) Empty module width 58.5 - 88.5 - 118.5 cm [23" - 34 7/8" - 46 5/8"].
- (D) Hood width min. 240 - max. 420 cm [min. 94 1/2" - max. 165 3/8"].
- (E) Extraction pipe ø13.5 cm [ø5 3/8"].
- (F) Electric motor.
- (G) Bottom shelf with LED LINE lighting.
- (H) Top shelf (optional - only available for hood h. 97 [38 1/4"]-).
- (I) Steel supporting upright.
- (L) Suspended ceiling.
- (M) Corrugated aluminium pipe ø15 cm [5 7/8"].
- (N) Minimum gap between hob pan stands - base of hood 55 cm [21 5/8"].
- (O) Hob pan stand height.

CAPPA AD ISOLA ASPIRANTE CON ASPIRAZIONE INTERNA vista frontale e laterale
DUCTED ISLAND HOOD WITH INNER ASPIRATION front view and side view

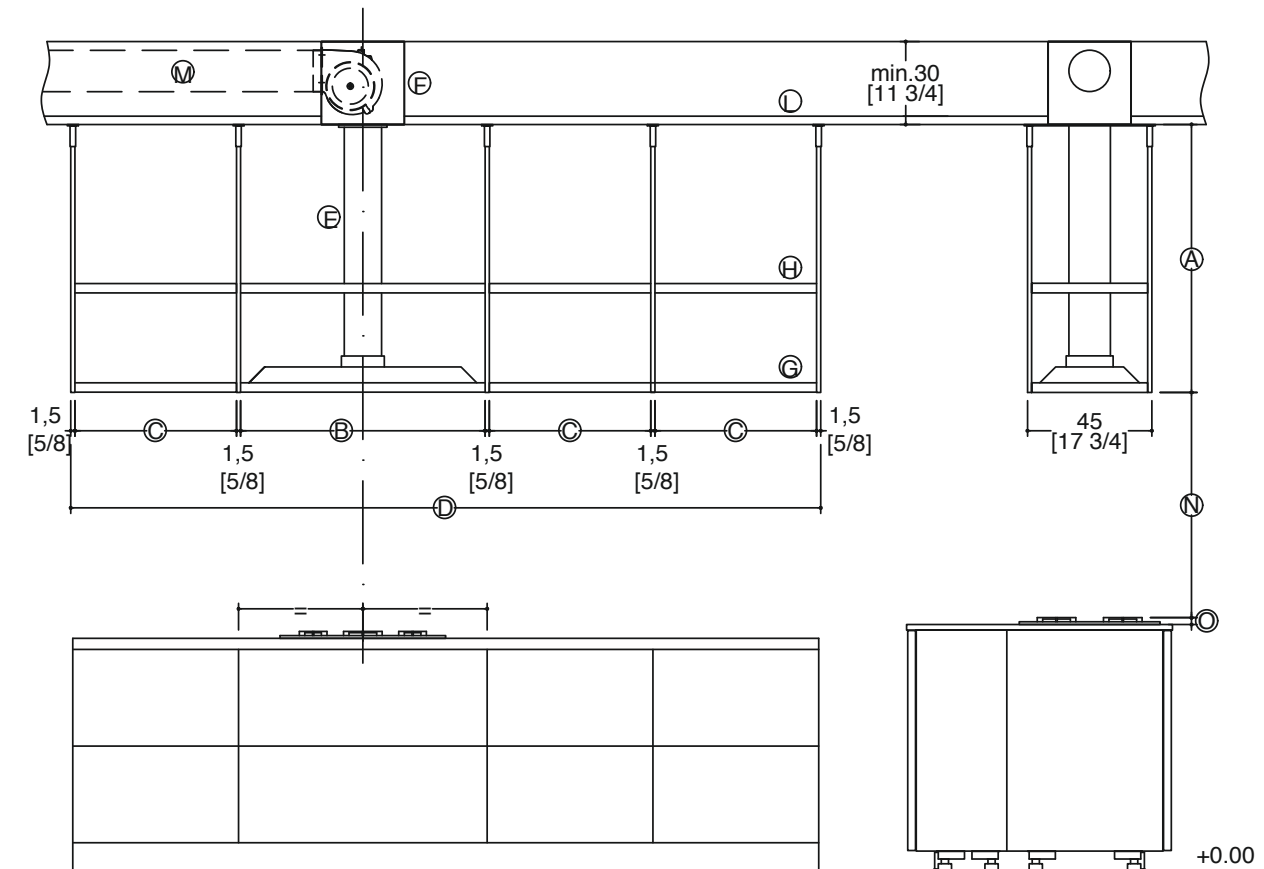

CAPPA AD ISOLA FILTRANTE CON ASPIRAZIONE LATERALE vista frontale e laterale
FILTERING ISLAND HOOD WITH SIDE ASPIRATION front view and side view

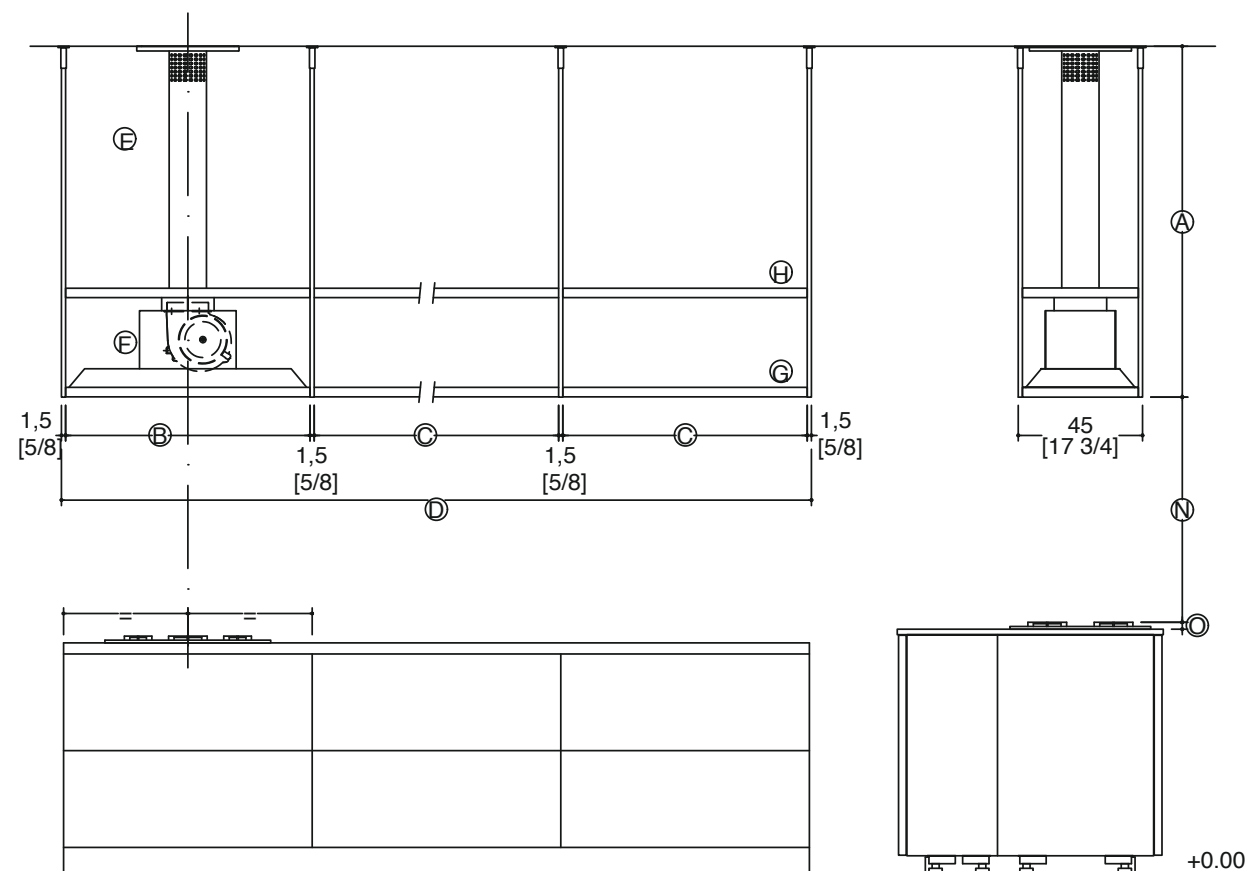

Caratteristiche

- (A) Altezza cappa 97 - 127 cm [38 1/4" - 50"].
- (B) Larghezza modulo cappa 88,5 - 118,5 cm [34 7/8" - 46 5/8"].
- (C) Larghezza modulo libero 58,5 - 88,5 - 118,5 cm [23" - 34 7/8" - 46 5/8"].
- (D) Larghezza cappa min. 180 - max. 420 cm [min. 70 7/8" - max. 165 3/8"].
- (E) Tubo d'aspirazione ø13,5 cm [ø5 3/8"] con feritoie per fuoriuscita aria filtrata.
- (F) Motore elettrico.
- (G) Ripiano inferiore dotato di illuminazione LED LINE.
- (H) Ripiano superiore (opzionale).
- (I) Spalla in acciaio portante.
- (N) Distanza minima griglie piano cottura - fondale cappa 55 cm [21 5/8"].
- (O) Altezza griglie piano cottura.

Consultare il listino di vendita per la componibilità della cappa.

CAPPA AD ISOLA FILTRANTE CON ASPIRAZIONE INTERNA vista frontale e laterale
FILTERING ISLAND HOOD WITH INNER ASPIRATION front view and side view

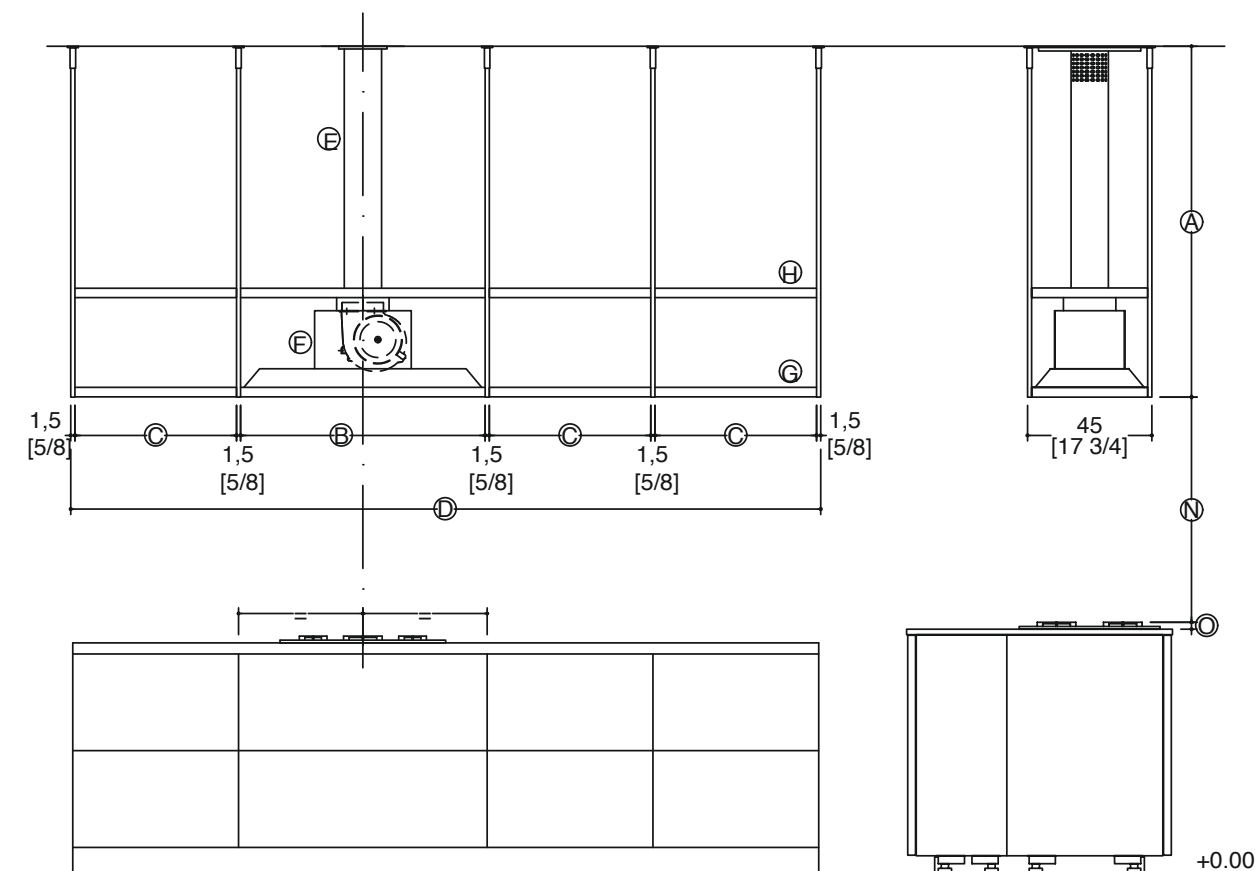

Characteristics

- (A) Hood height 97 - 127 cm [38 1/4" - 50"].
- (B) Hood module width 88.5 - 118.5 cm [34 7/8" - 46 5/8"].
- (C) Empty module width 58.5 - 88.5 - 118.5 cm [23" - 34 7/8" - 46 5/8"].
- (D) Hood width min. 180 - max. 420 cm [min. 70 7/8" - max. 165 3/8"].
- (E) Extraction pipe ø13.5 cm [ø5 3/8"] with filtered air outlet vents.
- (F) Electric motor.
- (G) Bottom shelf with LED LINE lighting.
- (H) Top shelf (optional).
- (I) Steel supporting upright.
- (N) Minimum gap between hob pan stands - base of hood 55 cm [21 5/8"].
- (O) Hob pan stand height.

Refer to sales price list for hood modularity.

ACCESSORI
ACCESSORIES

modulo tipo "A"
module type "A"

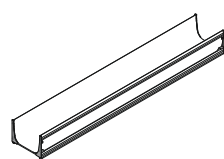

modulo tipo "B"
module type "B"

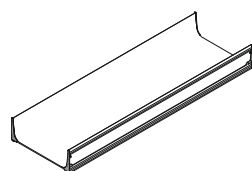

accessori per modulo tipo "A"
accessories for module type "A"



(1)



(2)

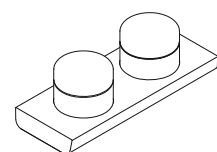

(5)

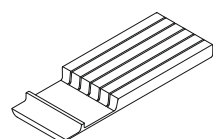

(3)

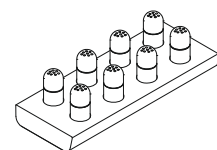

(6)

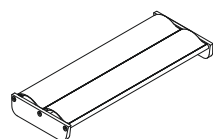

(4)

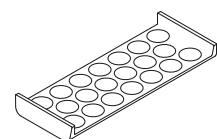

(7)

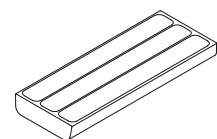

(8)

LEGENDA (cm)

- 1 = spalletta divisorio per modulo tipo "A" 6,7 x 1,5
- 2 = spalletta divisorio per modulo tipo "B" 14,1 x 1,5
- 3 = portacoltelli 14,1 x 37
- 4 = portapelliole 14,1 x 37
- 5 = portabarattoli 14,1 x 37
- 6 = portaspargisale/pepe 14,1 x 37
- 7 = porta capsule caffè 14,1 x 37
- 8 = porta spezie 14,1 x 37

KEY TO DIMENSION (inches)

- 1 = partition for module type "A" 2 5/8 x 5/8
- 2 = partition for module type "B" 5 1/2 x 5/8
- 3 = knife rack 5 1/2 x 14 5/8
- 4 = kitchen film holder 5 1/2 x 14 5/8
- 5 = jar rack 5 1/2 x 14 5/8
- 6 = salt and pepper rack 5 1/2 x 14 5/8
- 7 = rack f/espresso caps 5 1/2 x 14 5/8
- 8 = spice rack 5 1/2 x 14 5/8

Caratteristiche

Attrezzature interne per cassetti con struttura in alluminio anodizzato. Sono composti da due diversi moduli (A) e (B) che si vanno ad unire tra loro formando diverse configurazioni e possibilità di scelta per le più svariate esigenze, all'interno dei quali è possibile inserire o meno i diversi accessori. Per le finiture degli accessori Legno fare riferimento al listino. Massimo ordine, massima capienza e massima funzionalità.

Vincoli

Inseribile all'interno di cassetti con sponda Legrabox, disponibili nelle larghezze 45 - 60 - 90 - 120 cm [17 3/4"] - [23 5/8"] - [35 3/8"] - [47 1/4"], o nei cassetti delle strutture giorno K-System, disponibili nelle larghezze 60 - 70 - 90 - 120 cm [23 5/8"] - [27 1/2"] - [35 3/8"] - [47 1/4"], con l'utilizzo di appositi compensatori laterali in legno.

Characteristics

Internal equipment for drawers with anodised aluminium structure. The system comprises two different modules (A) and (B) which are joined together to form different configurations and options for the most widely varying needs, and can be fitted with the various accessories if required. Refer to the price list for the finishes of Wood accessories. Absolutely tidy, wonderfully roomy and completely convenient.

Constraints

Can be fitted inside drawers with Legrabox side, available in widths 45 - 60 - 90 - 120 cm [17 3/4"] - [23 5/8"] - [35 3/8"] - [47 1/4"], or in the drawers of K-System open structures, available in widths 60 - 70 - 90 - 120 cm [23 5/8"] - [27 1/2"] - [35 3/8"] - [47 1/4"], using special wooden filler strips at the sides.

MODULARITÀ CASSETTO LEGRABOX vista dall'alto e vista frontale
LEGRABOX DRAWER MODULARITY top view and front view

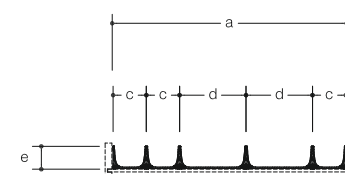
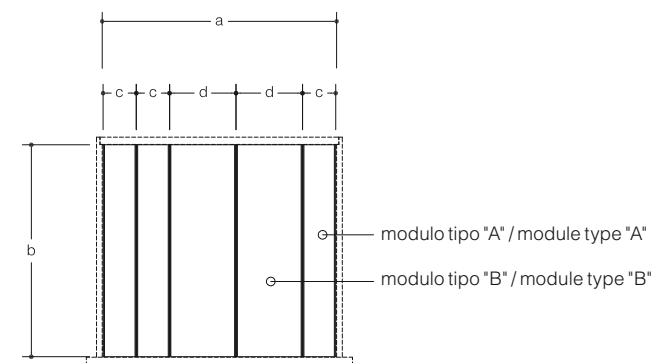

LEGENDA (cm)

- a = 37,2 - 52,2 - 82,2 - 112,2
- a' = 45,8 - 48,3 - 50,8 - 55,8 - 75,8 - 78,3 - 80,8 - 105,8 - 108,3 - 110,8
- b = 47,2 - 57,2
- b' = 47,2
- c = 7,4
- d = 14,8
- e = 5,1

KEY TO DIMENSION (inches)

- a = 14 5/8 - 20 1/2 - 32 3/8 - 44 1/8
- a' = 18 - 19 - 20 - 22 - 29 7/8 - 30 7/8 - 31 3/4 - 41 5/8 - 42 5/8 - 43 5/8
- b = 18 5/8 - 22 1/2
- b' = 18 5/8
- c = 2 7/8
- d = 5 7/8
- e = 2

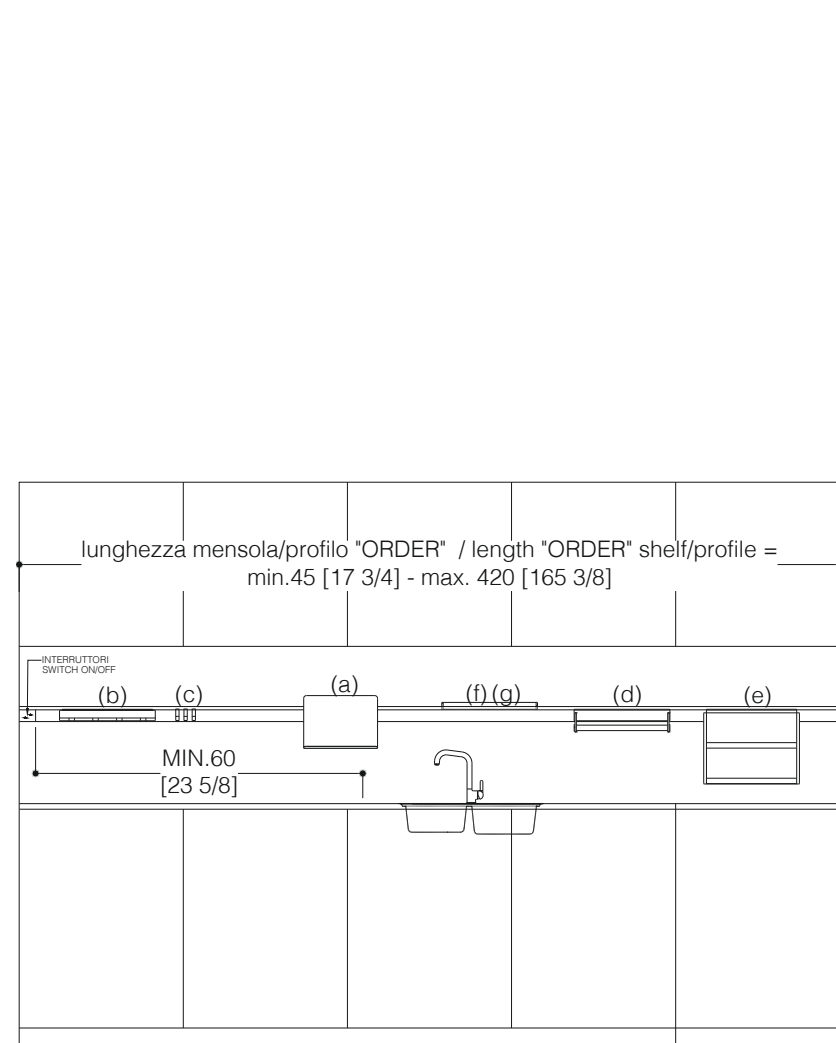
**Mensola Order****Caratteristiche**

Concepita per lo spazio tra base e pensile, la mensola è in alluminio anodizzato e si fissa direttamente a parete.

Fattibilità

La mensola può essere attrezzata con accessori e con illuminazione led attivabile tramite touch button. Per le finiture degli accessori Legno fare riferimento al listino. Può essere posizionata tra due schienali.

Vincoli

Per garantire il corretto aggancio di tutti gli accessori, la mensola deve avere una distanza minima dal top di 30 cm [11 3/4"] ed una distanza minima dal fondo del pensile di 22 cm [8 5/8"]. La lunghezza minima di una mensola è di 45 cm [17 3/4"], mentre la lunghezza massima della mensola realizzata in barra unica è di 420 cm [165 3/8"] con possibilità di posizionare il touch button all'estremità destra o sinistra e possibilità di illuminazione led. È consigliabile posizionare il touch button a una distanza minima di 60 cm [23 5/8"] dalla zona lavello, scolapiatti e/o piani cottura.

Profilo Order**Caratteristiche**

Concepito per ottimizzare ancora di più lo spazio tra base e pensile rispetto alla mensola, il profilo è in alluminio anodizzato e si fissa allo schienale.

Fattibilità

Può essere attrezzato con accessori che si agganciano. Per le finiture degli accessori Legno fare riferimento al listino. Può essere posizionato tra due schienali.

Vincoli

Per garantire il corretto aggancio di tutti gli accessori, il profilo deve avere una distanza minima dal top di 30 cm [11 3/4"] ed una distanza minima dal fondo del pensile di 10 cm [3 7/8"]. La lunghezza minima di un profilo è di 45 cm [17 3/4"], mentre la lunghezza massima del profilo realizzato in barra unica è di 420 cm [165 3/8"].

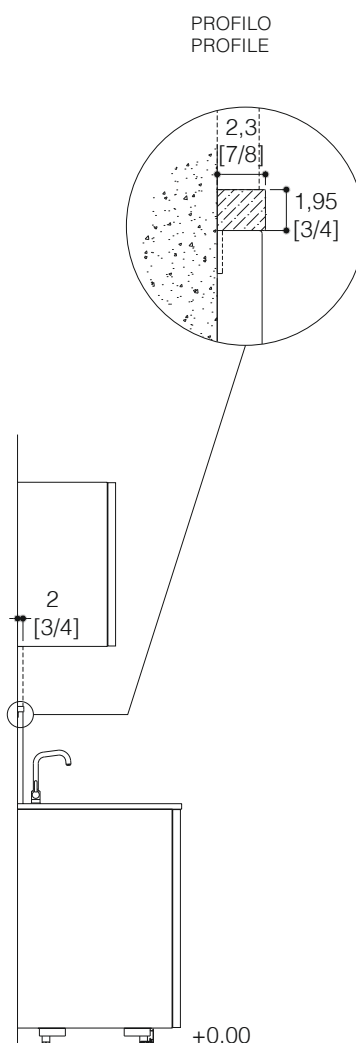
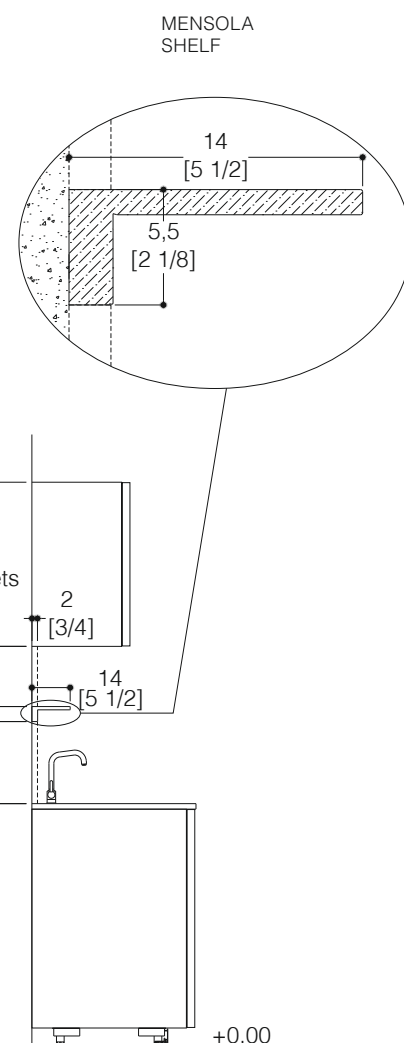
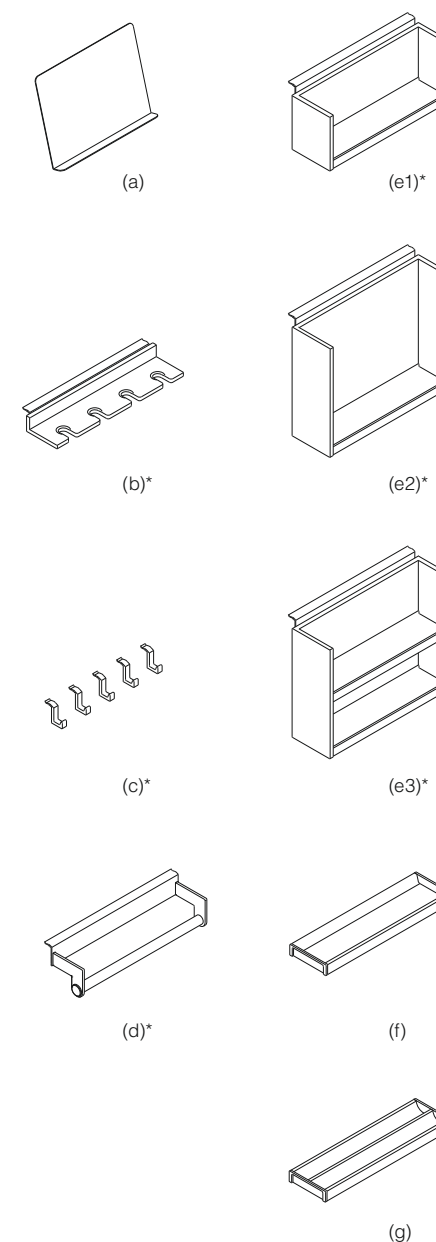
**ACCESSORI
ACCESSORIES****LEGENDA (cm)**

a = portatablet 27 x 20 cm
b = portabicchieri 35 x 4,3 cm
c = ganci 4,8 x 4,3 cm
d = portarotolo 35 x 8,4 cm
e = scaffaletto f1 35 x 13 cm - f2/f3 35 x 26 cm
f = vaschetta 35 x 2,7 cm
g = porta pellicole 35 x 2,7 cm

KEY TO DIMENSION (inches)

a = tablet holder [10 5/8 x 5/8]
b = glass rack [3 3/4 x 1 3/4]
c = hangers [1 7/8 x 1 3/4]
d = roll holder [13 3/4 x 3 1/4]
e = rack f1 [13 3/4 x 5 1/8] - f2/f3 [13 3/4 x 10 1/4]
f = tray [13 3/4 x 1 1/8]
g = kitchen film holder [13 3/4 x 1 1/8]

* Accessori compatibili con profilo Order
Accessories compatible with Order profile

Order shelf**Characteristics**

Designed for the midway space, the shelf is in anodised aluminium and is mounted directly on the wall.

Feasibility

The shelf can be fitted with accessories and with Led lighting with touch button on-off control. Refer to the price list of the finishes of Wood accessories. It can be placed between two wall claddings.

Constraints

To allow correct connection of all accessories, the shelf must be at least 30 cm [11 3/4"] above the worktop and at least 22 cm [8 5/8"] from the bottom of the wall unit. The minimum length of a shelf is 45 cm [17 3/4"], while the maximum length of a shelf produced in a single bar is 420 cm [165 3/8"]. The touch button can be placed at the right or left end, and Led lighting can be fitted. The touch button should be installed at least 60 cm [23 5/8"] from the sink zone, drainer units and/or hobs.

Order rail**Characteristics**

Designed for even greater optimisation of the midway space than with a shelf, the rail is in anodised aluminium and is mounted on the wall cladding.

Feasibility

Can be fitted with accessories which hook onto to it. Refer to the price list of the finishes of Wood accessories. It can be placed between two wall claddings.

Constraints

To allow correct connection of all accessories, the rail must be at least 30 cm [11 3/4"] above the worktop and at least 10 cm [3 7/8"] from the bottom of the wall unit. The minimum length of a rail is 45 cm [17 3/4"], while the maximum length of a rail produced in a single bar is 420 cm [165 3/8"].

MODULARITÀ vista frontale, laterale e in pianta
MODULARITY front view, side view and plan view

TIPO "A"
TYPE "A"

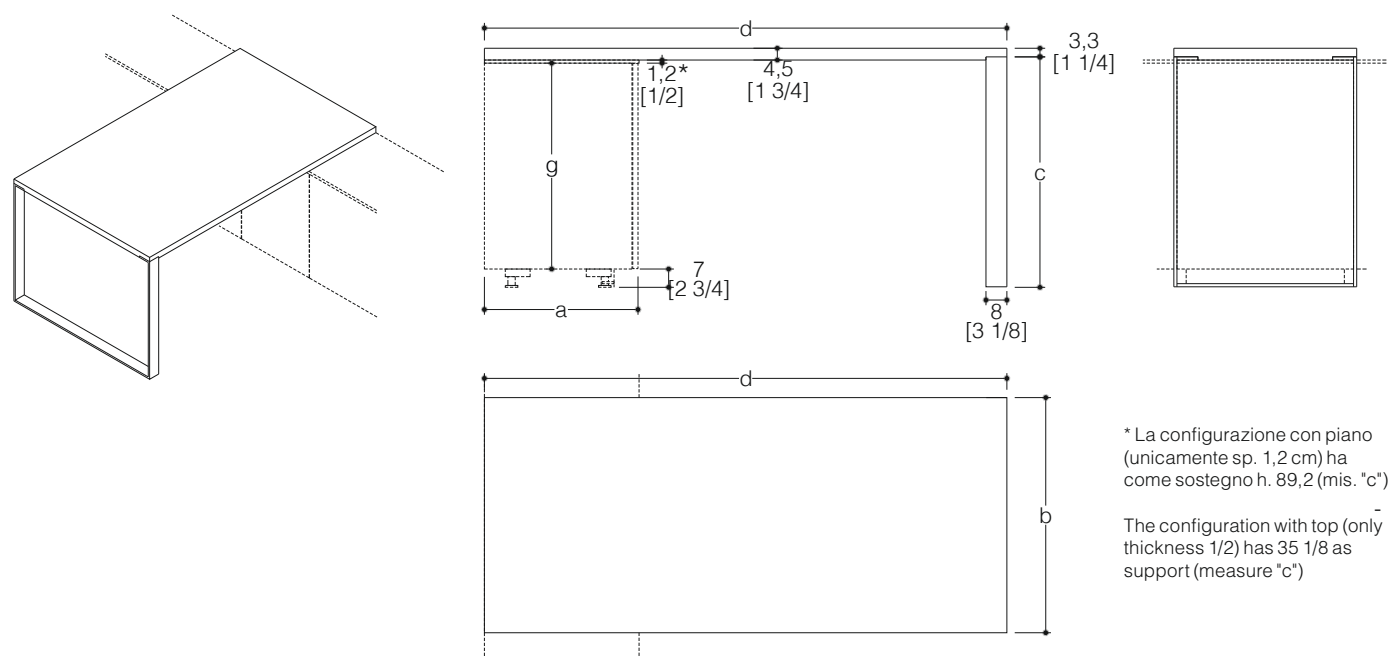

* La configurazione con piano (unicamente sp. 1,2 cm) ha come sostegno h. 89,2 (mis. "c")
The configuration with top (only thickness 1/2) has 35 1/8 as support (measure "c")

TIPO "B"
TYPE "B"

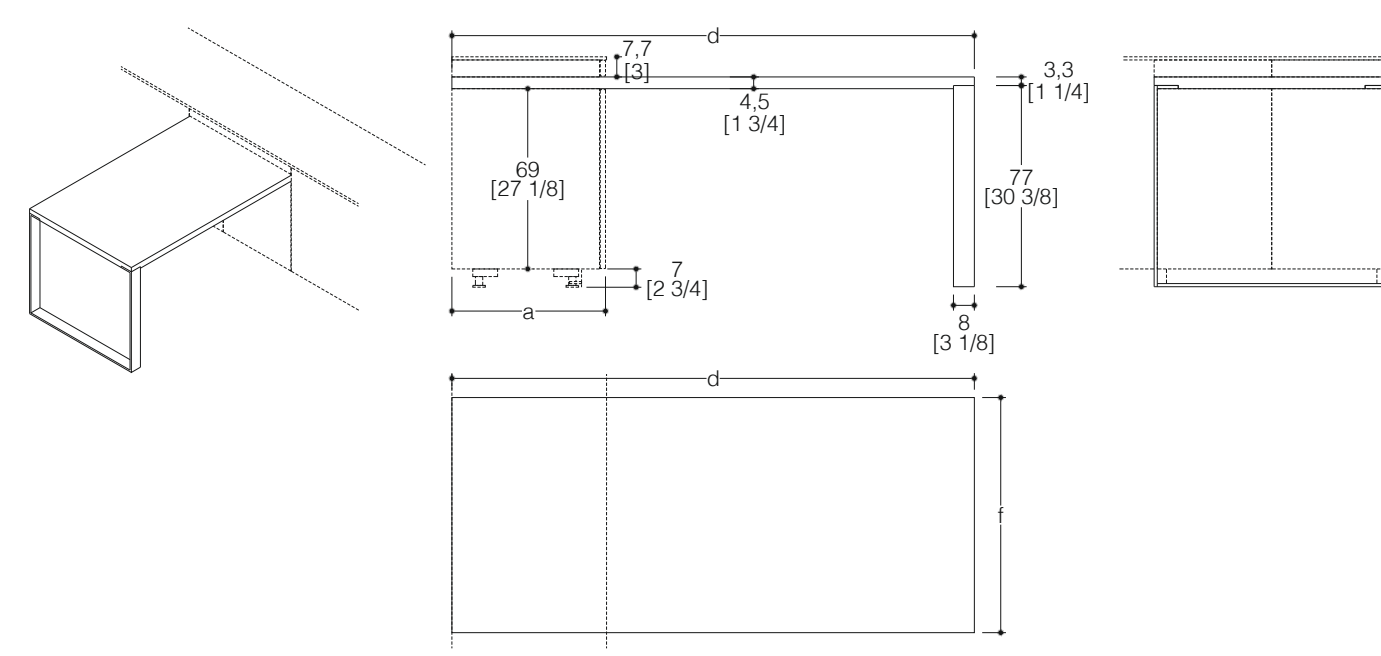

Caratteristiche

Il Tavolo Line Table ha una piana di spessore 4,5 cm [1 3/4"] che appoggia su un sostegno di metallo verniciato. È possibile personalizzare la struttura nelle finiture laccate del programma Sign. È possibile personalizzare la piana nelle finiture legno del programma Sign. Può essere posizionato su top o basi perpendicolarmente alla composizione o su top o basi in testa a una penisola o ad un'isola. Altrimenti può essere interposto tra due basi in posizione interna o a sbalzo. Lunghezza massima 250 cm [98 3/8"].

Fattibilità

Si possono impiegare basi con profondità pari a 60 cm [23 5/8"], 70 cm [27 1/2"] e 80 cm [31 1/2"]; non sono ammesse basi con profondità pari a 35 cm [13 3/4"]. Il tavolo Line Table è abbinabile al canale retro base Organizer. Sui lati a vista delle basi è possibile prevedere fianchi in finitura o copri fianchi spessore 1,2 cm [1/2"].

Vincoli

Per la versione a sbalzo, riduzioni/aumenti dimensionali in profondità e spessore, non sono ammessi.

Characteristics

The Line Table has a top 4.5 cm [1 3/4"] thick resting on a painted metal support, which can be customised in the lacquered finishes of the Sign programme. The top can be customised in the wood finishes of the Sign programme. It can be placed on worktops or base units perpendicular to the composition, on worktops or base units at the end of a composition, or on an island. Otherwise it can be installed between two base units, within the line of the composition or overhanging. Maximum length 250 cm [98 3/8"].

Feasibility

Base units with depth of 60 cm [23 5/8"] 70 cm [27 1/2"] and 80 cm [31 1/2"] can be used; base units with depth 35 cm [13 3/4"] are not permitted. The Line Table can be combined with the Organizer rear tidy system. Side panels matching door finish or side facing panels 1.2 cm [1/2"] thick can be used on the visible sides of the base units.

Constraints

No reductions/increases in depth or thickness are permitted for the overhanging version.

LEGENDA (cm)

a = 60 - 70 - 80
b = 70 - 90 - 120
c = 77 - 88 - 89,2
d = max 250
e = 97,4 - 96,3 - 118,4 - 120
f = 90 - 120
g = 69 - 80

KEY TO DIMENSION (inches)

a = 23 5/8 - 27 1/2 - 31 1/2
b = 27 1/2 - 35 3/8 - 47 1/4
c = 30 3/8 - 34 5/8 - 35 1/8
d = max 98 3/8
e = 38 3/8 - 37 7/8 - 46 5/8 - 47 1/4
f = 35 3/8 - 47 1/4
g = 27 1/8 - 31 1/2

MODULARITÀ vista frontale, laterale e in pianta
MODULARITY front view, side view and plan view

TIPO "C"
TYPE "C"

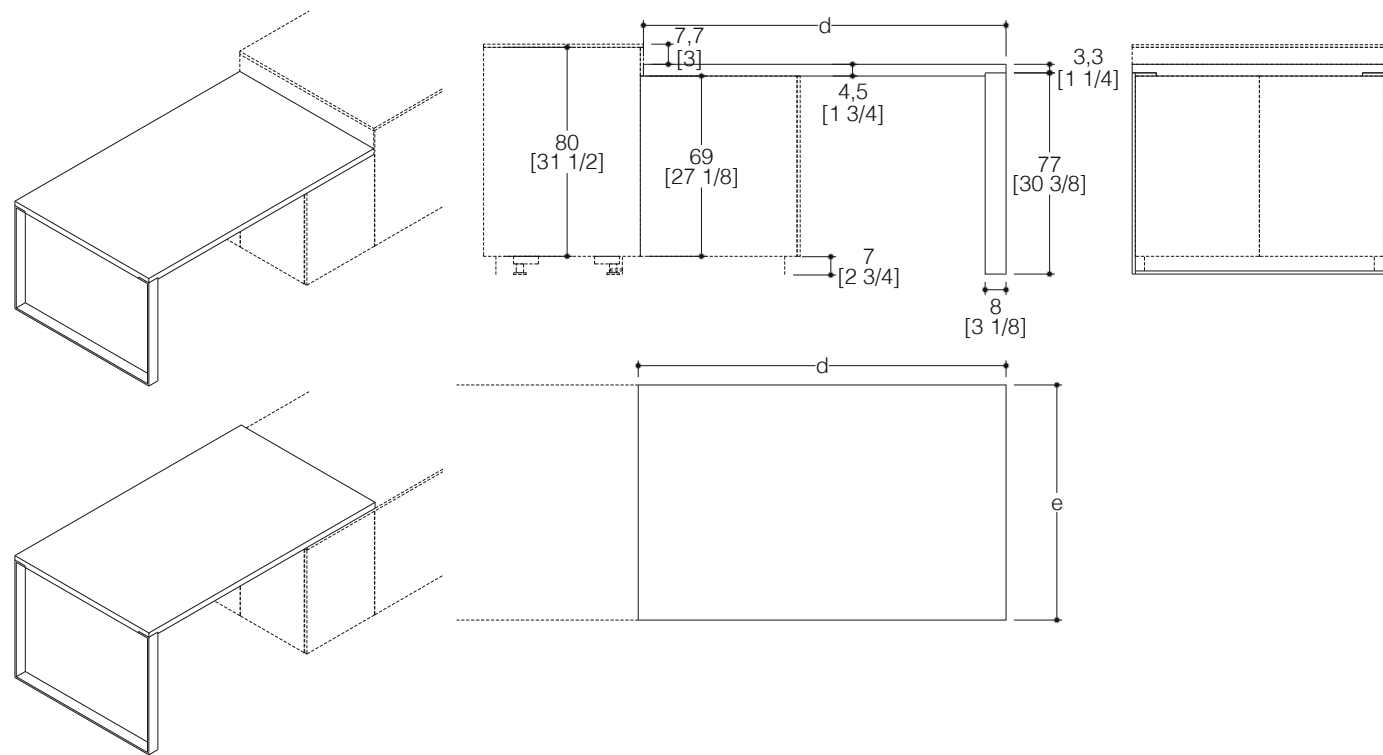

TIPO "D"
TYPE "D"

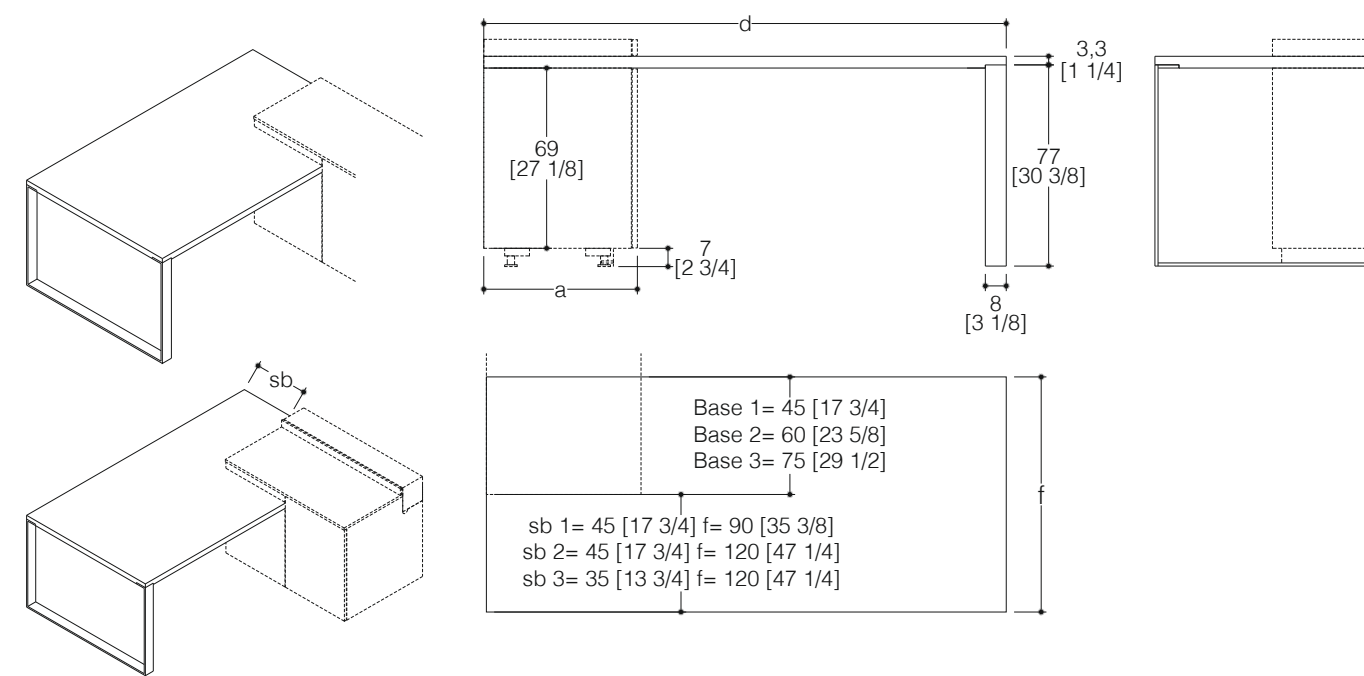

LEGENDA (cm)
a = 60 - 70 - 80
b = 70 - 90 - 120
c = 77 - 88 - 89,2
d = max 250
e = 97,4 - 96,3 - 118,4 - 120
f = 90 - 120
g = 69 - 80

KEY TO DIMENSION (inches)
a = 23 5/8 - 27 1/2 - 31 1/2
b = 27 1/2 - 35 3/8 - 47 1/4
c = 30 3/8 - 34 5/8 - 35 1/8
d = max 98 3/8
e = 38 3/8 - 37 7/8 - 46 5/8 - 47 1/4
f = 35 3/8 - 47 1/4
g = 27 1/8 - 31 1/2

BACK SYSTEM CON ACCESSORI FIT vista esplosa
BACK SYSTEM WITH FIT ACCESSORIES exploded view

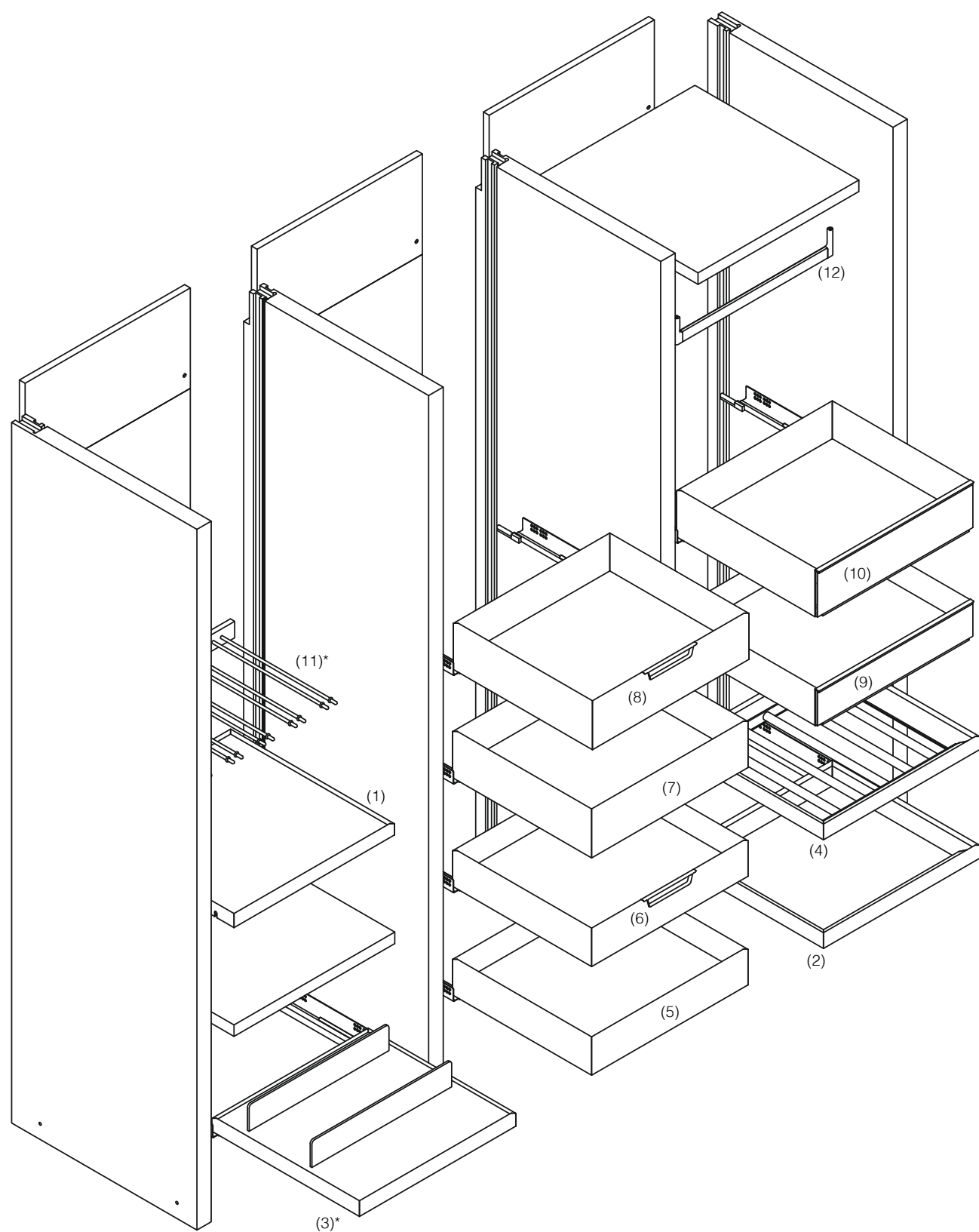

BASI E COLONNE CON ACCESSORI FIT vista esplosa
BASE CABINETS AND TALL UNIT WITH FIT ACCESSORIES exploded view

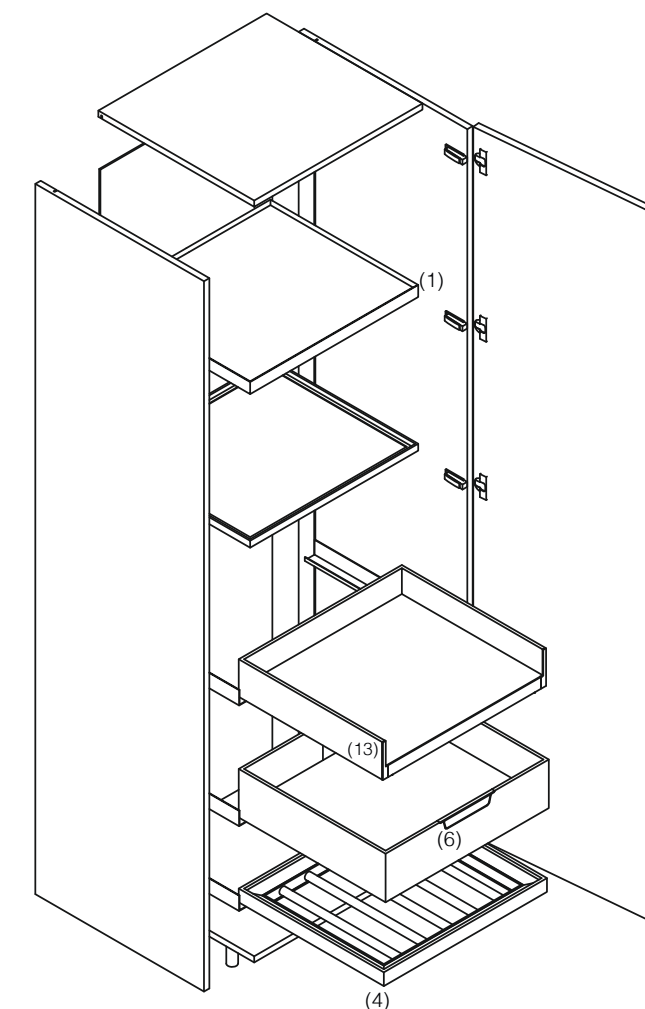
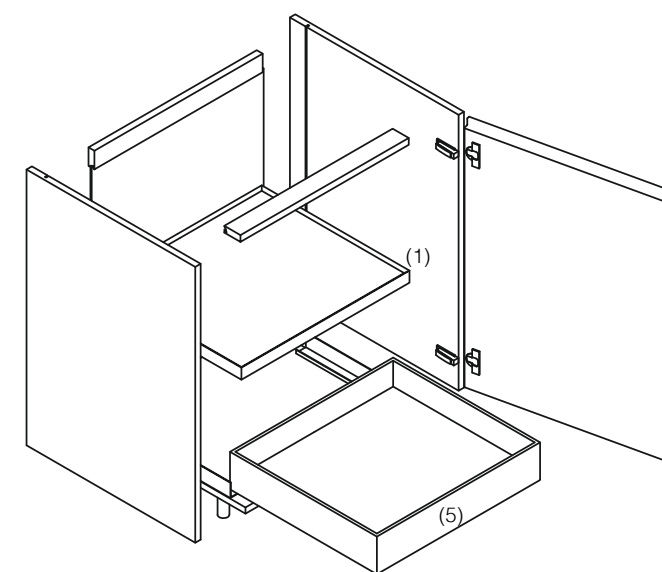

Caratteristiche

Le strutture Back System prevedono soluzioni lineari, ad angolo e dedicate per l'inserimento di elettrodomestici, zone lavaggio di servizio e schiene a specchio. All'interno dei vani previsti è possibile inserire diverse tipologie di accessori, compresi i Fit, per realizzare composizioni personalizzate. Tutti gli accessori sono spostabili in altezza. I moduli h 76 – 87 cm [29 7/8" – 34 1/4"] sono previsti solo in composizioni lineari a parete.

Fattibilità

Sono previsti dei moduli su cui è possibile personalizzare la larghezza, in questo caso si potranno inserire solamente i ripiani in melaminico o con telaio alluminio e vetro ed eventualmente l'appendiabiti. È possibile ridurre in altezza le spalle h 213 – 249 – 273 cm [83 3/4" - 98" - 107 3/8"]. È possibile ridurre la profondità delle spalle fino alla misura minima di 35 cm [13 3/4"]. I moduli h 76 – 87 cm [29 7/8" – 34 1/4"] possono essere scostati dalla parete di 10 cm [3 7/8"] per impiegare piani p 70 cm [27 1/2"], a condizione che i fianchi non siano a vista e quindi siano adiacenti ad un copri fianco, ad una parete o un armadio ad angolo. Nelle spalle delle strutture colonne è possibile inserire l'illuminazione led, attivabile tramite interruttore remoto. È possibile attrezzare la schiena posteriore dei moduli colonna con una barra elettrificata.

Vincoli

È necessario lasciare almeno 4 cm [1 5/8"] tra il lato superiore delle spalle ed un eventuale soffitto. A fine composizione è necessario lasciare almeno 4 cm [1 5/8"] tra la spalla terminale ed una eventuale parete. Non è possibile realizzare soluzioni fuori squadra. Non è possibile inserire forni con apertura battente. Non è possibile utilizzare sopra armadi. È sconsigliato realizzare dei moduli privi di accessori interni. All'interno della struttura colonna per lavello è obbligatorio inserire uno schienale in materiale piano, in modo da salvaguardare la schiena in melaminico del modulo stesso. In questo modulo non è possibile inserire l'illuminazione led. Non è possibile inserire i portabicchieri sulla schiena a specchio.

Characteristics

Back System structures offer linear and corner solutions and specific solutions for the installation of appliances, service washing zones and mirror back panels. Various types of accessories, including Fit, can be installed inside the compartments provided, in order to create custom compositions. The heights of all accessories can be varied. Modules h 76 – 87 cm [29 7/8" – 34 1/4"] are only for inclusion in linear wall compositions.

Feasibility

The width of some modules can be customised; in this case, only the melamine shelves, glass shelves with aluminium frame, and clothes hanging rail can be installed. The height of the uprights h 213 – 249 – 273 cm [83 3/4" - 98" - 107 3/8"] can be reduced. The depth of uprights can be reduced down to a minimum of 35 cm [13 3/4"]. Modules h 76 – 87 cm [29 7/8" - 34 1/4"] may be placed 10 cm [3 7/8"] from the wall to allow the use of worktops d 70 cm [27 1/2"], provided the sides are not visible, meaning that they are next to a side facing panel, a wall or a corner cupboard. Led lighting, controlled via a remote switch, can be incorporated in the uprights of the tall unit structures. An electrified rail can be fitted on the back panel of tall unit modules.

Constraints

A gap of at least 4 cm [1 5/8"] must be left between the top edge of the uprights and any ceiling above. At the end of the composition, a gap of at least 4 cm [1 5/8"] must be left between the end upright and any wall. Non right-angle corners are not possible. Ovens with laterally hinged doors cannot be installed. Top boxes cannot be used. The creation of modules without internal accessories is not recommended. The sink tall unit structure must include a back cladding in the worktop material to protect the melamine back panel of the module itself. Led lighting cannot be fitted in this module. The glass rack cannot be installed on the mirror back panel.

MODULARITÀ vista frontale e laterale
 MODULARITY front view and side view

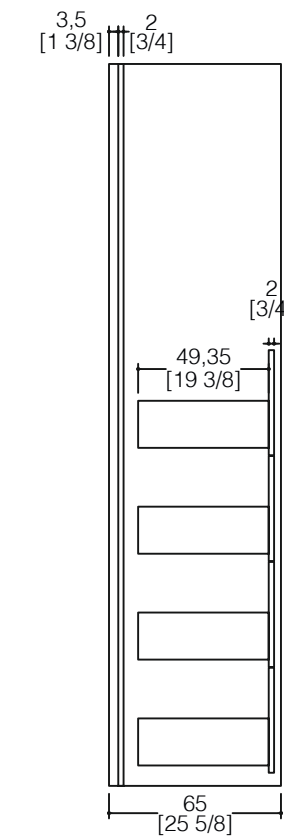
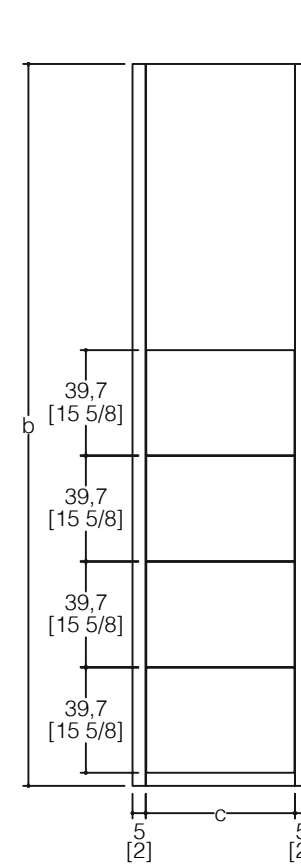
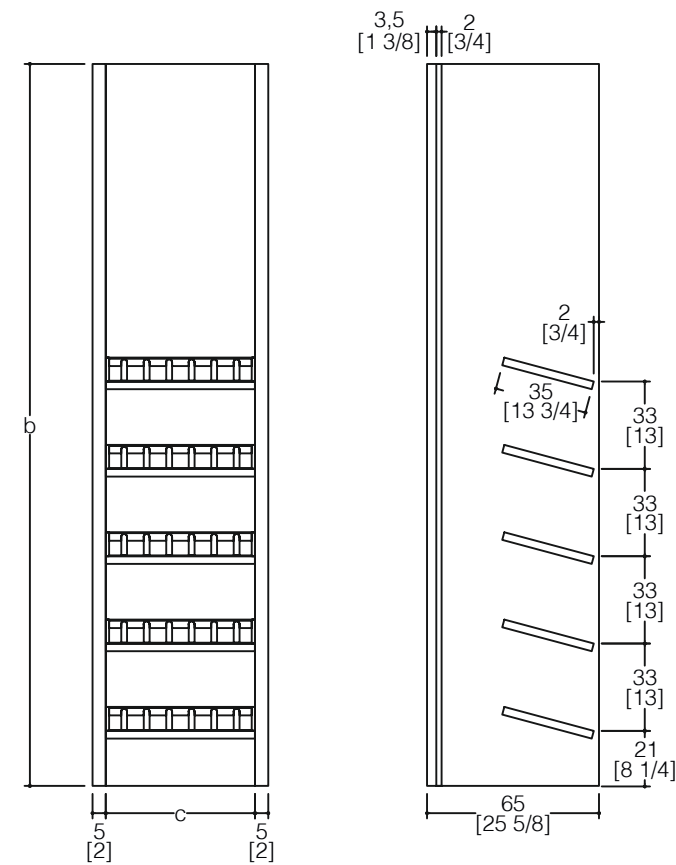
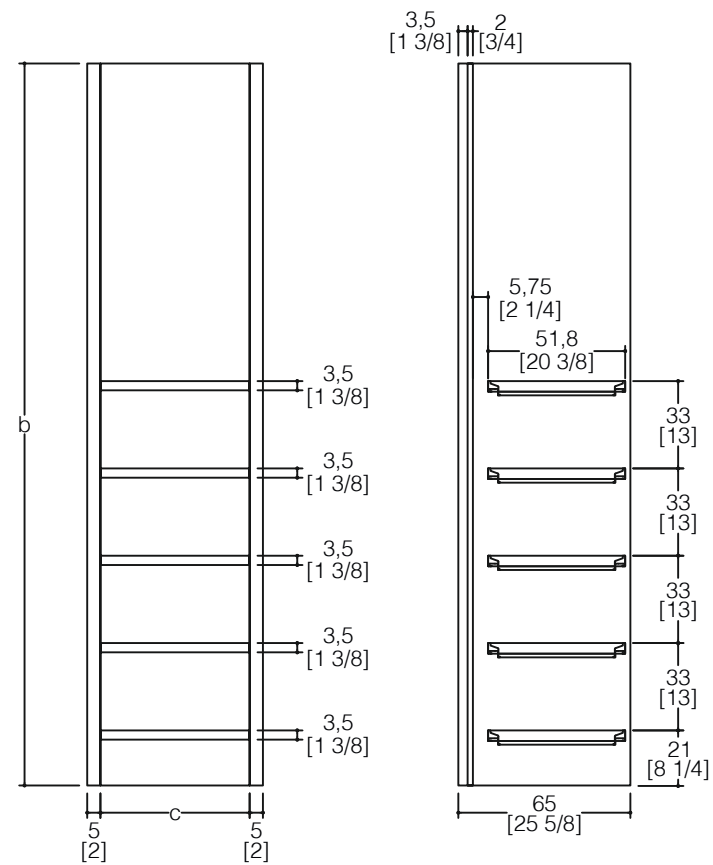
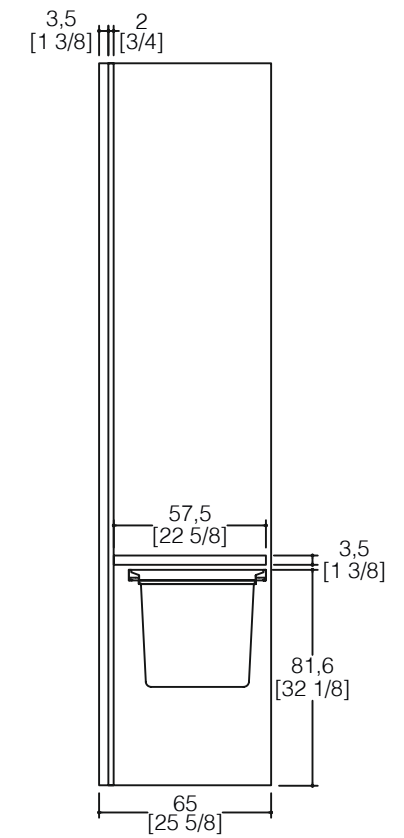
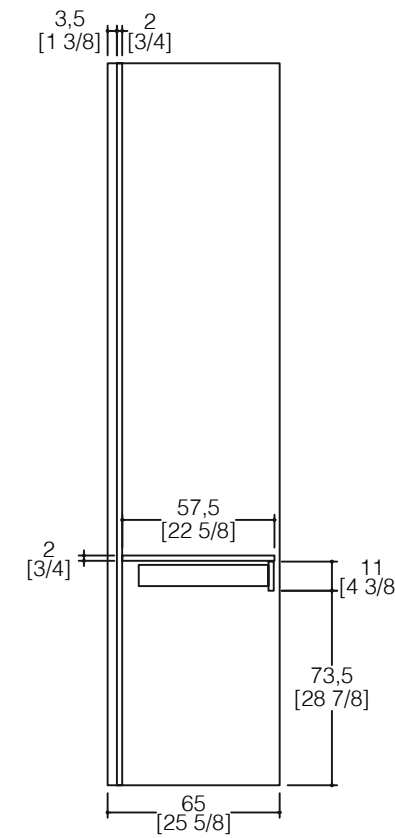
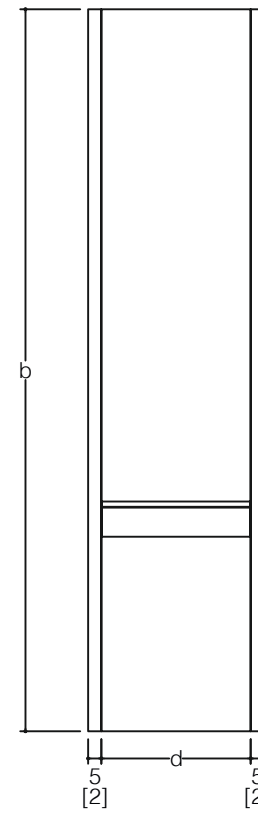
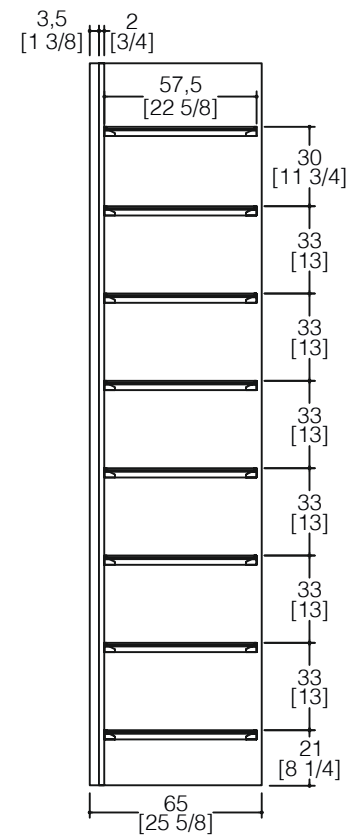
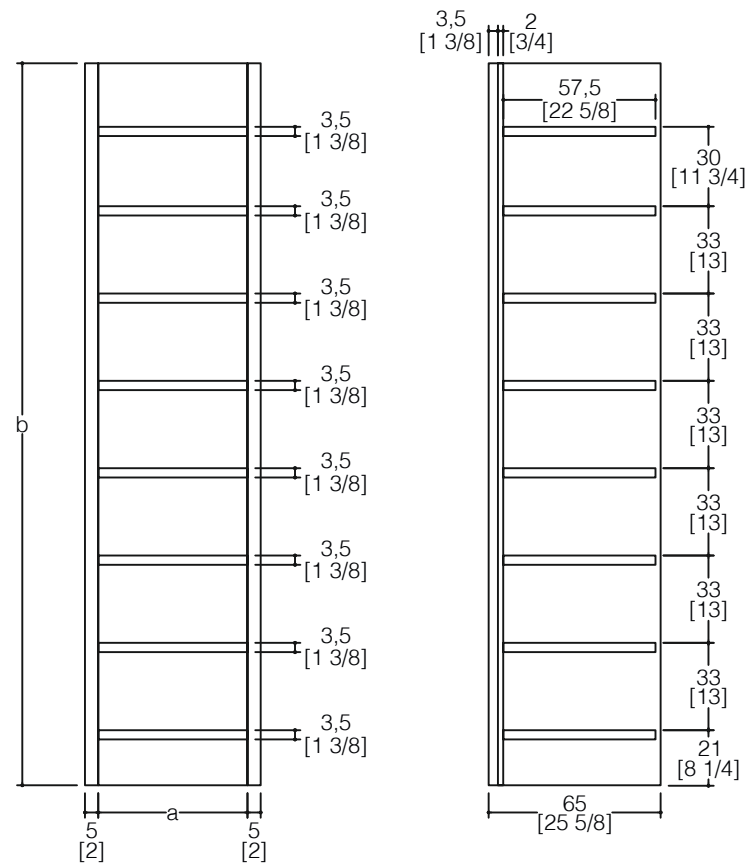

LEGENDA (cm)
 a = 26,4 - 41,4 - 56,4 - 60 - 63 - 82 - 86,4 - 116,4
 b = 213 - 249 - 273
 c = 56,4 - 86,4 - 116,4
 d = 41,4 - 56,4 - 86,4 - 116,4
 e = 12,8 - 16
 f = 26,4 - 56,4 - 86,4

KEY TO DIMENSION (inches)
 a = 10 3/8 - 16 1/4 - 22 1/4 - 23 5/8 - 24 3/4 - 32 1/4 - 34 - 45 7/8
 b = 83 3/4 - 98 - 107 3/8
 c = 22 1/4 - 34 - 47 7/8
 d = 16 1/4 - 22 1/4 - 34 - 47 7/8
 e = 5 - 6 1/4
 f = 10 3/8 - 22 1/4 - 34

MODULARITÀ vista frontale e laterale
 MODULARITY front view and side view

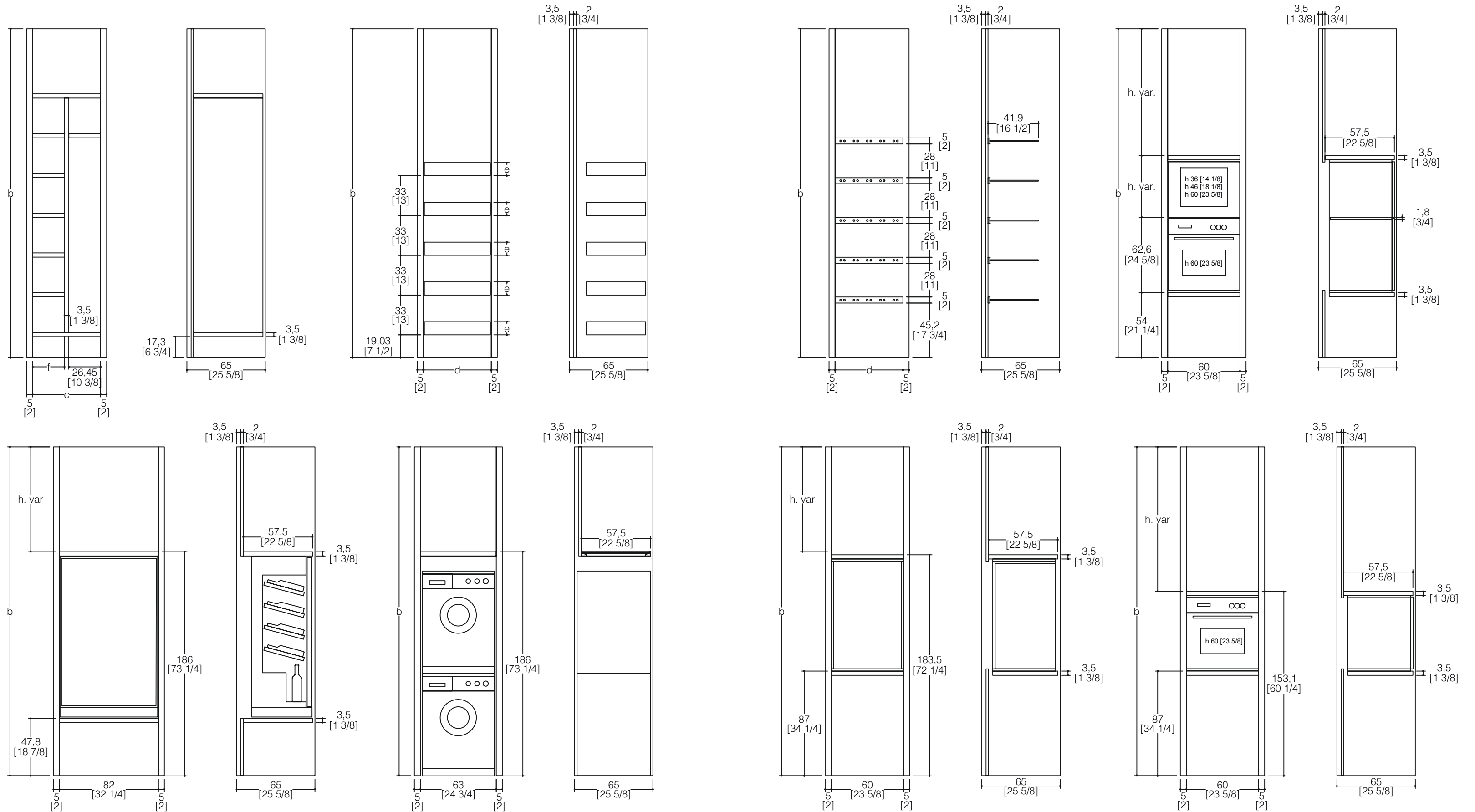

MODULARITÀ vista frontale e laterale
 MODULARITY front view and side view

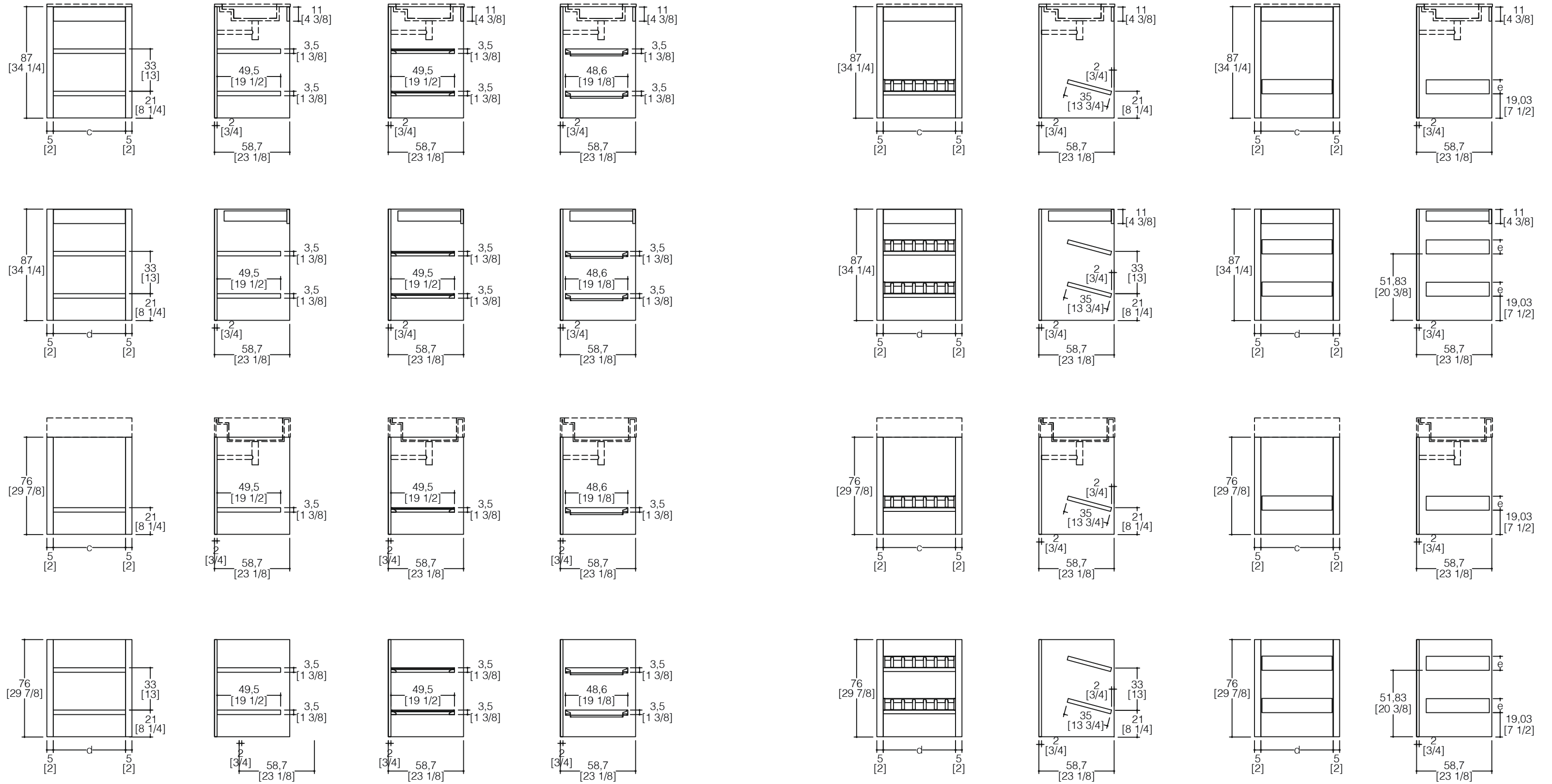

MODULARITÀ vista frontale e laterale
MODULARITY front view and side view

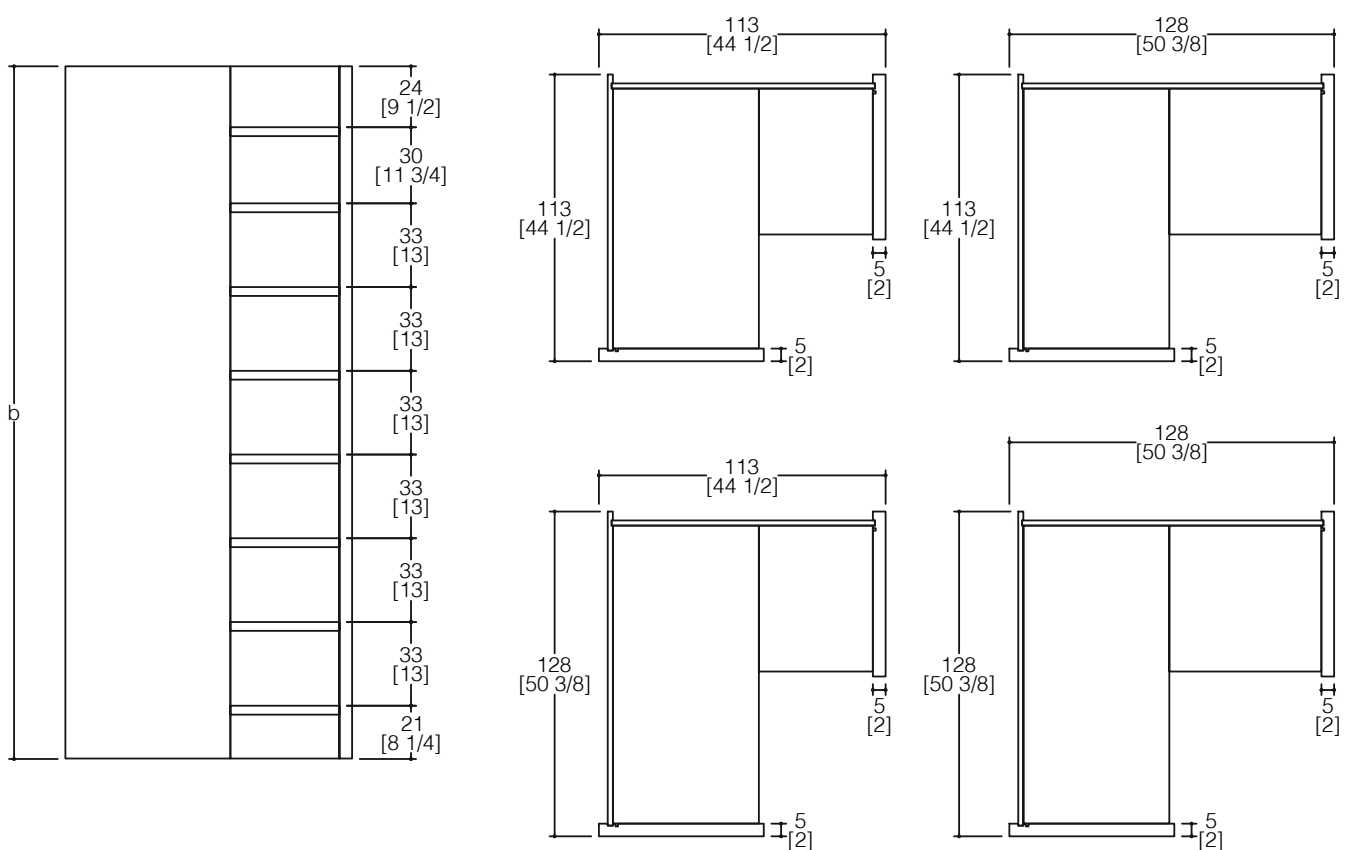
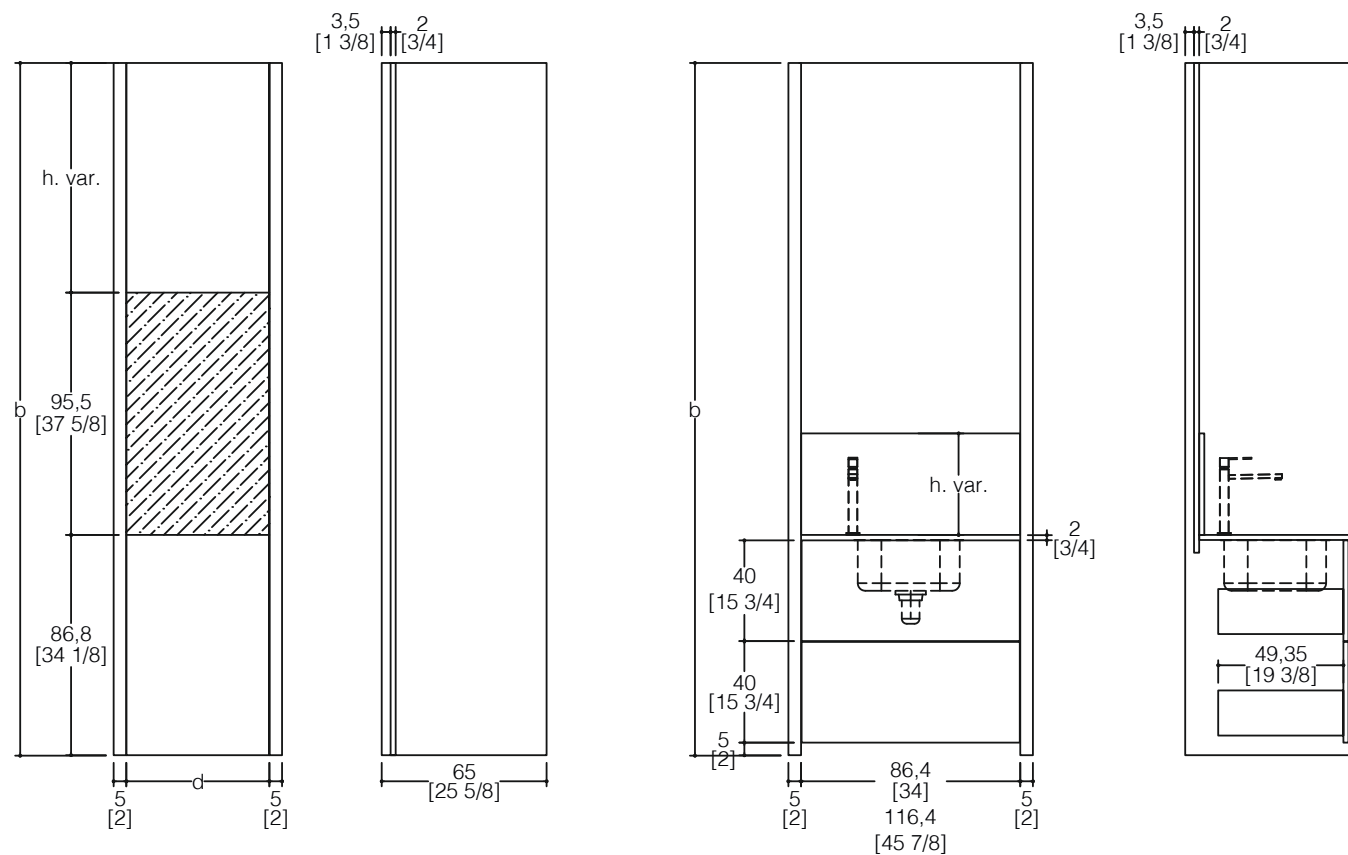

ACCESSORI FIT
FIT ACCESSORIES

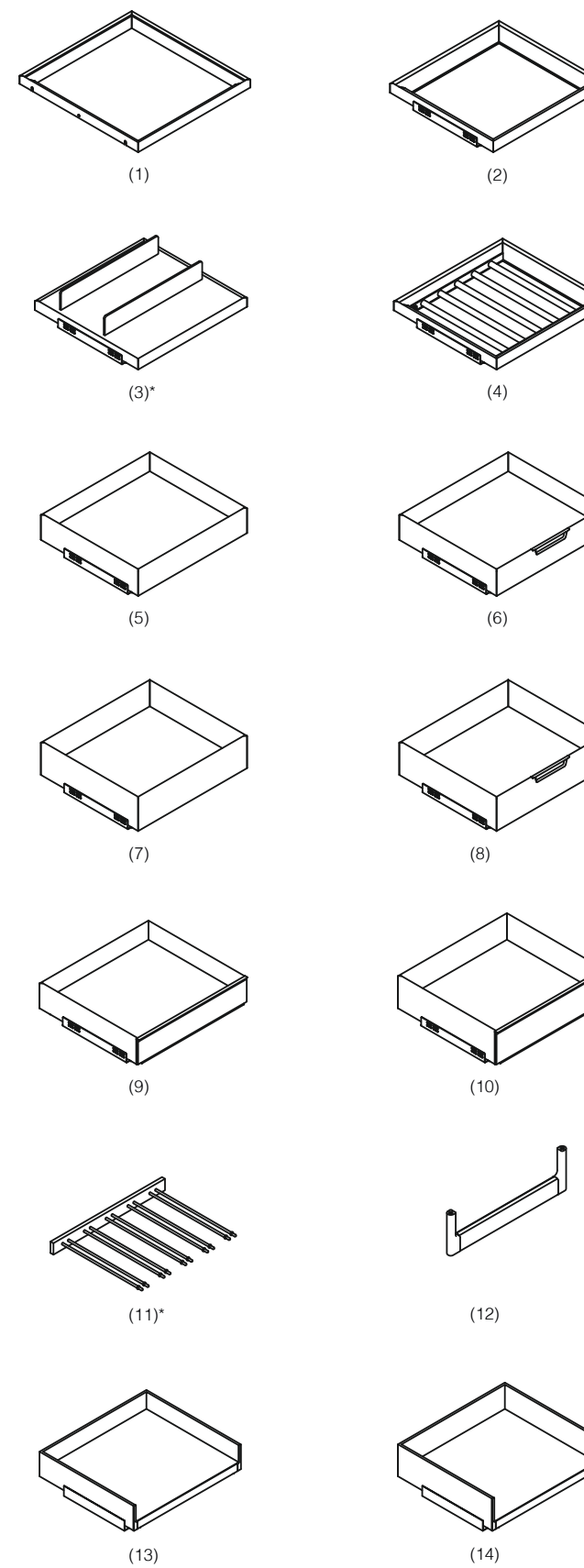

- LEGENDA (cm)
1 = ripiano con telaio alluminio e vetro
2 = ripiano con telaio alluminio e vetro/legno estraibile
3* = ripiano estraibile porta scarpe
4 = ripiano estraibile con portabottiglie
5 = cassetto alluminio h.12,8
6 = cassetto alluminio con maniglia h.12,8
7 = cassetto alluminio h.16
8 = cassetto alluminio con maniglia h.16
9 = cassetto con frontale in vetro h.12,8
10 = cassetto con frontale in vetro h.16
11* = porta bicchieri
12 = appendiabiti
13 = cestone estraibile senza frontale h.12,8
14 = cestone estraibile senza frontale h.16

* Accessori disponibili solo per Back System

- KEY TO DIMENSION (inches)
1 = shelf with aluminium frame and glass
2 = pull-out shelf with aluminium frame and glass/wood
3* = pull out shoe shelf
4 = pull out bottle holder shelf
5 = aluminium drawer h. 5
6 = aluminium drawer with handle h. 5
7 = aluminium drawer h. 6 1/4
8 = aluminium drawer with handle h. 6 1/4
9 = aluminium drawer with glass front h. 5
10 = aluminium drawer with glass front h. 6 1/4
11* = cup holder
12 = clothes hangers
13 = pull out basket without front h. 5
14 = pull out basket without front h. 6 1/4

* Accessories available only for Back System

NOTA
Per le misure vedere disegni
For measurements see drawings

Credits:

101 Copenhagen, Agapecasa, Alivar, Amini Carpets, BassamFellows, BERGHOFF WORLDWIDE, Besana Carpet Lab, Bisol1542, Bitossi Home, Bormioli Rocco, Carl Hansen & Søn, Ciù Ciù Tenimenti Bartolomei, Coltelleria Berti, Tradizioni Associate, Danese Milano, Dovetusai Milano, Eva Solo, Fiskars, Frama, Galleria Altai Milano, Giopato & Coombes Gallery, Hands on Design, Hario Italy, HKliving, Design & Lifestyle Italia, Iittala distribuito da Seambe, Living Divani, Manaresi, Mattiazzi, MMairo, Monteverro, MUJI, Nude, Pinetti, Rimadesio, Romagnoli Arredi, Sambonet, Society Limonta, Svenskt Tenn, Tiipoi, Venturini Baldini, Verpan, ZUCCHI
Le opere fotografate sono di Marco Solzi (marcosolzi.com)

Concept: Giuseppe Bavuso
Graphic project: Simona Frigerio
Photo: Federico Cedrone
Styling: Martina Lucatelli
ha collaborato Martina Dalla Bona

Pre-press: Selecolor
Print: Grapho5

Ernestomeda è dotata di un Sistema di Gestione della Qualità UNI EN ISO 9001, un Sistema di Gestione Ambientale UNI EN ISO 14001 e un Sistema di Gestione Salute e Sicurezza UNI ISO 45001. Tutti i Sistemi sono stati certificati dall'Ente Internazionale SGS.

Ernestomeda has a Quality Management System -UNI EN ISO 9001- an Environmental Management System -UNI EN ISO 14001- and an Health and Safety Management System -UNI ISO 45001-. All the Systems have been certified by the SGS international organisation.



1140.007.02.2022.3000.90118834.500

